

Dibas Bhandari

Intelligent Nestbox

Helsinki Metropolia University of Applied Sciences

Bachelor of Engineering

Degree Programme : Electronics

Bachelor's Thesis

Date : 6th April, 2017

Author Title	Dibas Bhandari Intelligent Nestbox
Number of Pages Date	45 pages + 7 appendices 6 th April, 2017
Degree	Bachelor of Engineering
Degree Programme	Electronics
Specialisation option	
Instructor(s)	Matti Fischer, Principal Lecturer
<p>The aim of this project was to develop a simple prototype of the nestbox with different sensors and camera which could gather the information from the physical environment of the nestbox, help to monitor every activity of the bird inside it and provide the information to the user in simple and systematic way.</p> <p>The system consisted of the Temperature Sensor “TMP36”, Humidity Sensor “DHT22” and Air Quality sensor “MQ135”. In addition, Infrared Sensor “IR Sensor Module” was used and Camera is connected to the system which was interfaced with the LabVIEW.</p> <p>Each sensor used, reads the physical signals around the nestbox and gives Analog or Digital Output which is processed by the Microcontroller. The camera installed can track down the feeding, breeding, hibernating, parental care, sibling competition, as well as other activities of the bird. All this information is then displayed on the computer screen with the help of LabVIEW.</p> <p>The prime goal of the project was achieved successfully. However, there are few problems with the efficiency of the components which can be corrected. Furthermore, various additional features as well as improvements regarding the scientific study of the bird’s habitat can be added to this project to make it even smarter. Still, the present status of the project can be used as foundation tool for the forthcoming development.</p>	
Keywords	Intelligent nestbox, Sensors, TMP36, DHT22, IR sensor module, MQ-135, Arduino, LabVIEW

Abbreviations

ADC	Analog to Digital Converter
CJC	Cold-Junction Compensation
RTD	Resistance Temperature Detectors
NTC	Negative-Temperature Coefficient
PTC	Positive-Temperature Coefficient
RH	Relative Humidity
NEP	Noise Equivalent Parameter
PWM	Pulse Width Modulation
EEPROM	Electrically Erasable Programmable Read-Only Memory
SRAM	Static Random Access Memory
IDE	Integrated Development Environment
UVC	Universal Visual Class
VI	Virtual Instruments

Contents

1	Introduction	1
2	Theoretical Background	1
2.1	Temperature Sensors	2
2.2	Humidity Sensor	6
2.3	Infrared Sensors or IR Sensors	9
2.4	Gas Sensors	13
3	Intelligent Nestbox	17
3.1	Microcontroller	18
3.2	Sensors	20
3.2.1	TMP36	20
3.2.2	DHT22	22
3.2.3	IR Sensor Module	24
3.2.4	MQ-135	26
3.3	Web Camera	27
4	Software	28
4.1	Arduino IDE	28
4.2	LabVIEW	29
4.3	Webcam.	30
5	Physical Implementations	30
6	Testing	36
6.1	Accuracy testing	36
6.2	Testing with LabVIEW	38
7	Installation and Observations	39
8	Functionality Testing and Discussions	39
9	Future possibilities of Intelligent Nestbox.	40
10	Conclusion	40
	References	42

Appendices

Appendix 1. Main Code

Appendix 2. Block diagram for Arduino readings in LabVIEW

Appendix 3. Block diagram for generating video in LabVIEW

Appendix 4. Test results with LabVIEW

Appendix 5. Installation of the DHT22, IR sensor module, Webcam and MQ-135 inside nestbox

Appendix 6. Installation of Tmp36 and IR sensor module outside the nestbox

Appendix 7. Microcontrollers connected with the sensors

1 Introduction

The scientific study of the behaviour of the bird with respect to the variation in the climatic conditions, their adaptation to their environment as well as their comprehensive activities inside their nest has always been a challenging task for the bird researchers, the Ornithologists. They put their valuable time, effort and money for research purpose and discover the interesting facts about their life cycle, which also helps monitor the changes in the ecosystem.

Like Ornithologists, many people are interested in bird watching and they want to know about the birds around them. But, they are unable to get access to these because few articles are published about the birds and not much audio-visual information is available. Furthermore, they are not able to follow the bird and keep an eye inside the nest like they can over their pets. Our Instructor, Mr. Matti Fischer, Principle Lecturer of Helsinki Metropolia UAS who is currently studying biology as hobby faced the same problem and thought of designing something which would enable him to see bird's activities inside the nest. Thus, this project 'Intelligent Nestbox' was proposed.

The main objective of this project was to design a device with different sensors that could be placed inside the nestbox which could read and analyse the temperature, humidity, carbon dioxide level inside it. In addition to it, the number of times a bird goes inside and outside of the nest could also be detected and the camera installed inside the nestbox keeps record of every activities inside the nestbox and displays it on computer screen or laptop. This project can facilitate many people like Mr. Matti Fischer to observe birds conveniently in a similar way like other pets, by investing a few hundred euros and sitting in comfort zone, unlike Ornithologists.

2 Theoretical Background

In these days, our daily chores are dependent on different types of sensors. From touch-sensitive mobile phones to automatically operating trains, sensors have been involved to aid our day to day life activities and we are unaware of it. Their extensive development has benefitted not only humans, but also other different living creatures on Earth.

Sensors are simply a device which distinguish the variation in physical and biological environment and notify the information through output devices in the form of electrical signals [1, 1]. They convert the real-world data, analog data, into simpler and readable form by using computer or any scientific device containing ADC (Analog to Digital Converter). Some of the sensors that are applicable in our daily life are proximity sensor, light sensor, thermometer, speedometer, gas sensors etc. [1, 7-10]. In this project, the various sensors are used which are focussed below.

2.1 Temperature Sensors

The precise analysis of the temperature is important across a wide spectrum of activities of living beings. The accurate determination of the temperature, which is the degree of hotness or coldness of a body is one of the key parameter to be measured in industries, health science, meteorology, ecosystem, science and technologies. In scientific terms, temperature is cause for heat transfer by conduction, convection or radiation and measured in Degree Celsius ($^{\circ}\text{C}$), Degree Kelvin ($^{\circ}\text{K}$) or Degree Fahrenheit ($^{\circ}\text{F}$) by a device called as Thermometer. [2]

From the ancient times people were aware of the heat and had been continuously trying to access its intensity by measuring temperature. Today, temperature measurement is very necessary in modern electronic devices because they have very compact circuits and are capable of dissipating power in the form of heat. Knowledge about the temperature helps to protect vital components from damaging as well as reduces power consumption which is key factor for excellency in any device. [3, 3.29]

Although the simplest and commonly used phenomenon for temperature sensing is thermal expansion, which based on liquid-in-glass thermometers, they have now openly given way for electronics devices, i.e. sensors. They involve diverse method of temperature sensing like resistive, thermoelectric, semi conductive, optical, acoustic and piezoelectric sensors. [4]

The most common types of temperature sensors are discussed below.

Thermocouples

They are small, rugged and cost effective temperature sensors having wide range of measurement from -200°C to $+2300^{\circ}\text{C}$ with satisfactory accuracy and are generally applied in boilers, ovens water heaters and aircraft engines. The output of this sensor is few millivolts which needs to be amplified for further processing. They need two junctions, hot and cold junctions. They also termed as 'measurement junction' and 'reference junction' respectively. [5]

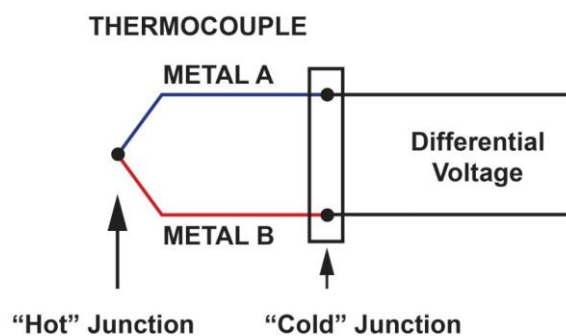

Figure 1: Thermocouple. Reprinted from John Austin [5]

In the above Figure 1, two dissimilar metals, 'Metal A' and 'Metal B' are connected at one end called as hot or measurement junction at any temperature above absolute zero. The next end where wires are not joined, is cold junction which is then connected to the signal conditioning circuitry traces. There will be a potential difference between two metals which is a function of the temperature of hot and cold junctions. By analysing the voltage generated, we can determine the temperature difference between two junctions. It must not be forgotten that it measures only temperature difference, not a real temperature. Therefore, the temperature of the cold junction should be known to calculate accurate temperature reading which is known as cold-junction compensation (CJC). [3, 3.39]

The commonly used thermocouples types are J, K, and T whose voltage differs at $52 \mu\text{V}/^{\circ}\text{C}$, $41 \mu\text{V}/^{\circ}\text{C}$, and $41 \mu\text{V}/^{\circ}\text{C}$ respectively at room temperature. Their wide temperature range, immunity against hazardous environmental conditions, no self-heating and simplicity makes them an excellent choice. However, low stability, less accuracy, need of extra amplification of output signals etc. can't be neglected. [5]

Resistance Temperature Detector (RTD)

These are sensors made up of Platinum (Pt) wire wrapped around a ceramic bobbin whose resistance is dependent on temperature and exhibit the behaviour like thermocouple but operate more linearly over wide temperature range and are more accurate and reliable. The nature of the material used in wire fluctuates the temperature-resistance relationship. Unlike copper and nickel, platinum illustrates higher linear resistance-temperature relationship and chemical inertness which makes it best choice for making RTD. It provides temperature accuracy of ± 0.2 °C in the range of temperature -200 °C to +850 °C. [3, 3.47]

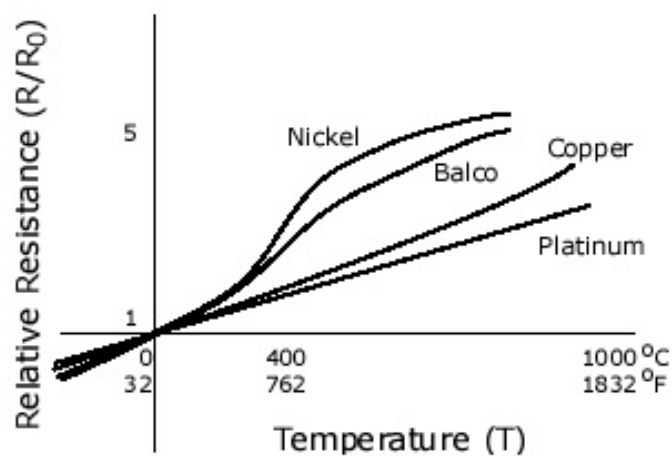

Figure 2: Curve for different RTD materials. Reprinted from [6]

The Figure 2 above represents the greater linearity of Platinum in comparison to Nickel, Balco and Copper. Slow operation, cost, requirement of external signalling and four wire, self-heating are the drawbacks of these sensors. [6]

Thermistors

Thermistors are also temperature sensing device like RTD, whose resistance value alters with change in temperature. However, it differs in composition and does not read temperatures like other sensors do. They are made up of semiconductor materials which exhibit the positive or negative temperature coefficient (NTC or PTC) and display highly non-linear relationship between temperature and resistance. In PTC, the temperature is directly proportional to resistance while vice-versa in case of NTC thermistors. Commonly used thermistors are NTC thermistors and have temperature range of -100°C to

+150°C and are broadly used in batteries, engines, coolants and freezers for automatic shutdown process in hot temperature. [6]

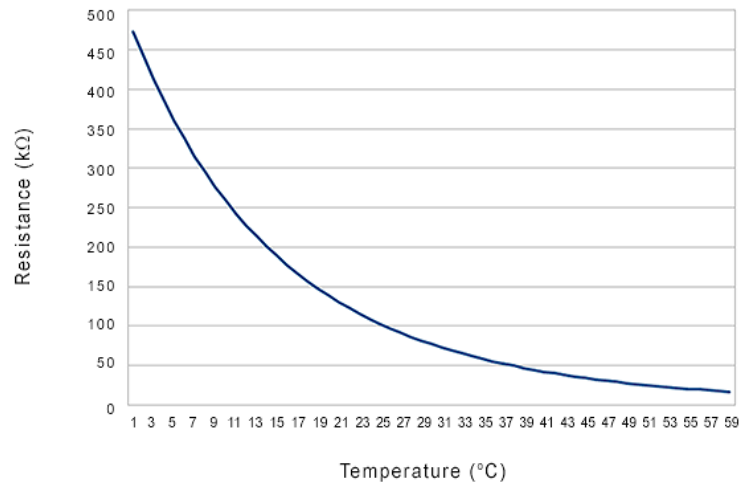

Figure 3: NTC Thermistor graph. Reprinted from [7]

The Figure 3 above depicts the resistance value of thermistor at different temperatures. The resistance value is decreased when there is increase in temperature.

Semiconductor Temperature Sensors

Semiconductor temperature sensors, popularly called as Integrated Circuits, i.e. IC are the electronic devices for sensing temperature assembled in same way as other semiconductor components. Numerous devices are created over thin silicon wafers and they are accessible in the market from different manufacturers, hence they are not universal type like thermocouples or RTDs. [8]

Most of these sensors are based on the temperature and current characteristics of the transistors. For any two transistors operating individually at constant collector current densities their difference in base-emitter voltage is directly proportional to the absolute temperature of transistors. The voltage thus generated is converted to single ended voltage or current, which is ultimately converted to Celsius or Fahrenheit temperature scale. Small size, linear outputs, low cost, limited temperature range (generally -40°C to +120), high accuracy and excellent thermal conductivity make them very applicable in embedded systems. They can be easily interfaced with other electronic devices like regulators,

digital signal processors, amplifiers and microcontrollers. There are different type semiconductor sensors which are listed below.

- Voltage Output Temperature Sensors: provide linear output voltage corresponding with temperature and low output impedance.
- Current Output Temperature Sensors: give high output impedance and functions as current regulators made to conduct $1 \mu\text{A}/^\circ\text{K}$.
- Digital Output Temperature Sensors: are advanced sensors with analog to digital converter inside an IC chip. They are unable to give standard digital interfaces and are not fit for devices that need to meet a standard.
- Resistance Temperature Sensors: gives output depending on temperature and resistance of semiconductor and can be made more stable than other sensors due to higher tolerance to ion migration.
- Diode temperature sensor: cheapest sensor made using PN junction diodes. [8]

The temperature sensor used in the project, Tm36 is a kind of semiconductor temperature sensor which is discussed below.

2.2 Humidity Sensor

The proportion of water content in the air, humidity, is very important for all living beings on Earth. The level of comfort is dependent on humidity, for example we may feel comfortable in -30°C during winter in Finland if the air is dry but it is uncomfortable during summer if the temperature rises to 30°C and air is moist. It is crucial factor for operating certain equipment having high-impedances electronic circuits, high voltage devices, electrostatic-sensitive components etc.in manufacturing industries because it may affect production cost, efficiency of the machines, as well as hamper the health and safety conditions of employees. Humidity control is essential in medical applications, chemical industries, food processing, and paper and textile industries as well as in domestic applications. [9]

The amount of water vapour in air may be mixture of different gases like nitrogen, argon, pure air etc. which can be determined by humidity measurement with the help of device termed as 'hygrometer'. Hygrometer is a humidity sensor that measures and reports the relative humidity (the ratio of actual moisture in the air to the highest amount of moisture that the air can hold at that temperature) in the air which makes them capable of measuring both temperature as well as moisture. Before, there had been many humidity sensors which were used several years. The first hygrometer was invented by Leonardo da Vinci which was hair-tension hygrometer which used animal or human hairs under tension because they show hygroscopic characteristics, length of hair changes with humidity. Later, a Psychrometer called as Wet-and-dry-thermometer consisting of one wet bulb and one dry bulb thermometer mounted on an arm came into existence followed by Sling Psychrometer which used thermometers attached to a handle or length of rope and could be rotated for detecting moisture. The moisture content, humidity could be determined by means of formula based on different readings of two thermometers. [10]

Those sensors were not efficient and accurate and were hence replaced by modern humidity sensors which are discussed below.

Capacitive Humidity Sensor

These are made on substrate of glass, ceramic, or silicon and their dielectrics layer is constructed from thin polymer film or metal oxide placed between two metal electrodes. The electrode is porous and thus allows water vapour present in air to dielectric layer. However, dielectric layer is not contaminated. The capacitance of the sensor is 100 to 500 pF at 50 % RH and the alternation in capacitance is directly proportional to change in humidity, typically 0.2 to 0.5 pf for each 1 % change. They measure humidity ranging from 5 % to 95 % with ± 2 % accuracy and response time is 30 to 60 seconds. Their performances decrease after couple of years. [11]

Resistive Humidity Sensor

These sensors are built with hygroscopic materials like conductive polymer, salt or treated substrate and the change in their electrical impedance measures the relative humidity. These materials are dependent on both temperature and humidity, so it makes temperature sensor also to be included with it. They can operate in temperature range

40 °C to 100 °C and provide accuracy up to ± 0.1 %. Their life expectancy is over five years. [11]

The Figure 4 below indicates the construction of Capacitive and Resistive Humidity Sensors.

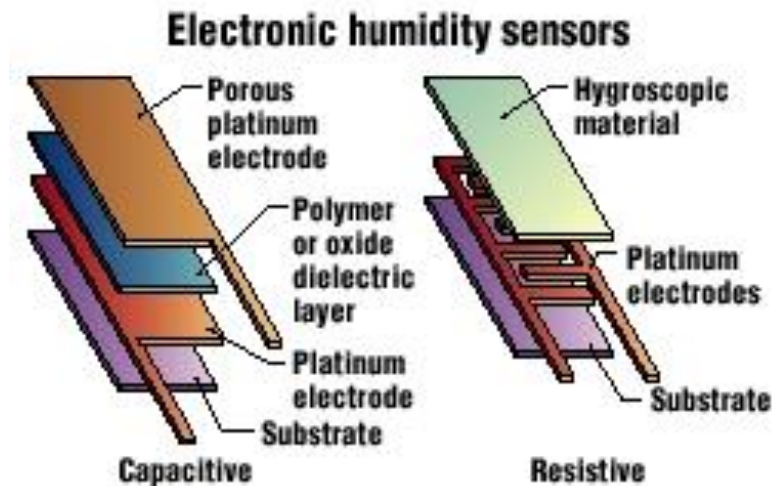

Figure 4: Capacitive and Resistive Humidity Sensors. Reprinted from [11]

The humidity sensor, DHT22 used in this project is a type of capacitive humidity sensor which will be explained below.

Thermal Humidity Sensor:

In this sensor, the humidity is measured due to change in thermal conductivity. It determines the absolute humidity rather than the relative humidity. [12]

Gravimetric Humidity Sensor

While most of the sensors are dependent on the volume of the air for measurement, these types of sensor measure the mass of an air sample compared to an equal volume of dry air. This is the most accurate and primary method of measurement and is used to calibrate less accurate humidity sensors and called as transfer standard. [12]

The Finnish Company developed the “Humicap” in 1973, a sensor for measuring humidity which consists of a thin film of water vapour sensitive polymer capable of changing its electrical capacitance with respect to atmospheric moisture. [10]

2.3 Infrared Sensors or IR Sensors

Infrared (IR) is an invisible radiant energy, electromagnetic radiations having wavelength longer than visible lights but smaller than microwaves extending from 0.75 μm to 1000 μm in infrared region. Depending on the wavelength, the infrared region can be classified as near infrared region (0.75 μm to 3 μm), mid-infrared region (3 μm to 6 μm) and far infrared region (greater than 6 μm). [13]

Everybody having temperature above 0 °K emit the infrared radiation whose intensity and wavelength depend on the temperature of that object. To detect those radiation, a sensor is used which is called as infrared sensors or IR sensor.

The system for distinguishing the infrared radiation can be explained by the block diagram shown in the Figure 5 below.

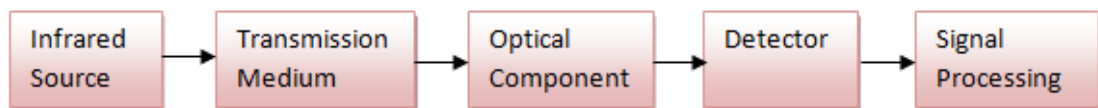

Figure 5: Block diagram showing infrared detection. Reprinted from [14]

- Objects above 0 °K emit infrared radiation and they can be classified as sources. Active sensors like IR lasers and LEDs as well as blackbody radiators, tungsten lamps, silicon carbides etc. can be considered as IR source.
- The transmission mediums are air, vacuum or optical fibres which can be affected by atmospheric Carbon dioxide, water vapour or other gases.
- Optical lenses, polyethylene Fresnel lenses, aluminium mirrors are the optical components which are used to focus/converge the infrared radiations. The materials for optical system are selected based on their transmittance/reflectance for desired wavelength of IR.
- The detector can be of two types, thermal and quantum. Thermal detector constitutes sensing materials which are independent of wavelength while quantum detector is wavelength dependent.

- The signal output from a detector are very small and hence require amplifiers for further processing. [14]

The performance of a detector is dependent on parameters like Photosensitivity or Responsivity, Noise Equivalent Power (NEP) and Detectivity (D^* : D-star). Responsivity is the Output Voltage/Current per watt of incident energy which is better if higher. Similarly, NEP is the amount of incident radiation when the signal to noise ratio is 1. And, D^* is the photosensitivity per unit area of detector which is a measure of S/N ratio of detector. It is inversely proportional to NEP. [14]

Types of Infra-Red Sensors

There are two kinds of infrared sensors depending on their functionality. They are Thermal Infrared Sensor and Quantum Infrared Sensors. [15]

Thermal Infrared Sensor

In this sensor, the incident infrared energy is absorbed which change the temperature of the material and the resultant change in physical properties of the material is used to generate the electrical output. They are independent of the wavelength of the incident infrared radiations but the signal depends upon the radiant power (its ability to change). These sensors generally operate at normal room temperature and are characterized by slow response and moderate sensitivity. They are widely utilized in Bolometers, pyroelectric infrared sensors and thermopiles. [13]

Quantum Infrared Sensor

The incident radiation is absorbed within the material by interaction of the electrons. The change in electronic distribution gives the electrical output and they are dependent on the wavelength of the incident radiations. Their perfection in signal to noise ratio increases the efficiency in performance as well as in responsive speed. Quantum sensors face hindrance in accurate measurement because they must be cooled. [13]

Also, there are two types of Infrared Sensors based on the working mechanism. They are Active Infrared Sensors and Passive Infrared Sensors.

Active Infrared Sensors

Active infrared sensors use both infrared source and infrared detector in such a way that IR emitted by the source is received by the receiver. The IR is emitted by the IR LED and is received by the Photodiode, phototransistor or photoelectric cells. For detection, there should be alternation of radiation in the process between emitting and receiving the IR radiation. Based on arrangement of the emitter and receiver, there are two kinds of active sensors mentioned below.

- Break beam sensor: In this type, the IR emitter and receiver is kept in such a way that the radiations falls directly into the receiver and the output altered when any opaque object interrupts the radiations between transmissions. They are commonly used for intrusion detection, counters and shaft encoder purposes.
- Reflectance sensors: It is based on the reflective property of IR. The positioning of emitter and receiver is made in such a way that the radiation from the emitter is deflected back to the receiver when any external object is spotted. They are widely used in intrusion detection, object detection, barcode decoding etc. [14]

The Figure 6 below shows the types of active infrared sensors.

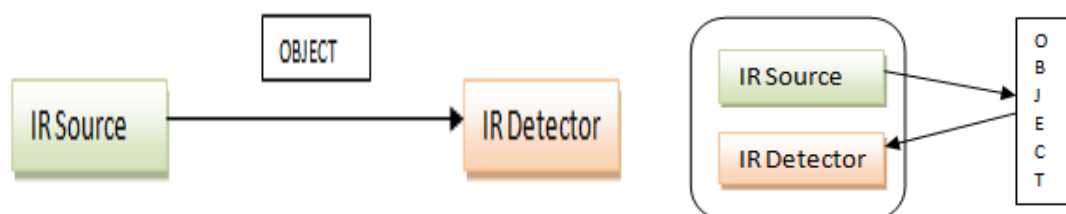

Figure 6: Break beam sensor and Reflectance sensor. Reprinted from [14]

The sensor used in this project is reflectance sensor which will be discussed below.

Passive Infrared Sensors

These sensors are just IR detectors and don't have their own IR source. They notice the infrared radiation from outer source or object which is in the field view of sensor and give readings or outputs based on the thermal input. There are various kinds of passive infrared sensors which are listed below.

- Thermocouple-Thermopile: is a detector with working mechanism like the thermocouple and converts temperature into an electrical signal. It has a 'hot' junction which is blackened to absorb the infrared radiation and 'cold' junction is maintained to ambient temperature of the detector. If the sensor senses anything radiating infrared, the temperature of 'hot' junction increases and due to the temperature difference between two junctions, there will be potential difference generated across the junctions which gives the output signal. These sensors are much less sensitive but respond to each wavelength.
- Bolometer: is a simple thermal detector consisting of the sensitive thermometer and a sink. When an incoming energy is interacted, the temperature of the thermometer is increased and due to difference in temperature between the thermometer and sink, the internal resistance is changed which is key factor for providing output signal or notification.
- Pyroelectric Infrared Sensor: PIR sensors contain two pins, '+ve' and '-ve' which are alerted when the source is present in the field of view. When the source radiation is near '+ve' pin, it gets activated and sensor value goes up. When the radiating source continues towards '-ve' pin, it gets activated and sensor value drops down. These changes in the pulses are what is detected by PIR sensor. The Figure 7 below explains the operation of the PIR sensors. [14]

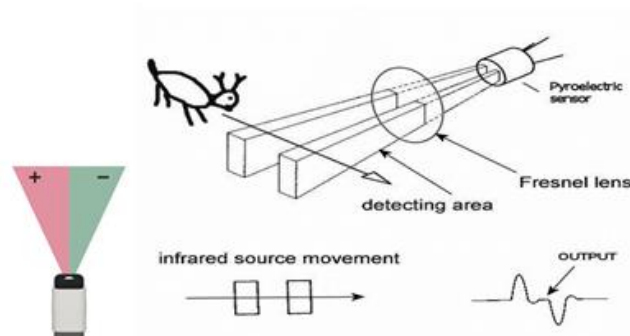

Figure 7: Diagram explaining operation of PIR sensor. Reprinted from [15]

The PIR sensors are widely used in security, robotics, lighting and household appliances. The use of Infrared Sensor is facilitating different areas such as Climatology, Meteorology, Night Vision, Photobiomodulation, Gas detectors, Water analysis, petroleum exploration, railway safety and many more. [13]

2.4 Gas Sensors

The environment around us consist of different proportion of gases which may be injurious to the living beings, polluted air from various industries and medical process, hence the identification of the gases and proper precautions is essential for the safety of humans, animals, plants and entire living beings. The traditional gas sensing technologies can alarm the situation with audio sound whenever there is gas leakage which are poisonous and not favourable for surrounding inhabitants. They are not so accurate and do not give real-time measurement as well as content of the gas in the air. Hence, the modern types of gas sensors are designed to identify the presence of certain gas along with their content are replacing the old ones. These sensors not only have high efficiency but are also cheap, small and comes with modern technologies. The various gas sensor available today in the market are discussed below. [16, 61-62]

Catalytic Sensors

These sensors are based on principle of catalytic combustion i.e. the combustible gases are burnt below their ignition point by certain chemical process. They were used in coal mines for detecting the methane and hydrogen gases. It is made up of coiled shaped Platinum wire coated with metal oxide which makes it stable and provides capacity to stay strong against vibrations and disturbances. The coated catalytical metal oxide gets oxidised when it encounters the gases and this reaction releases heat which makes the resistance of the Platinum wire to change. The concentration of the gases can be determined by the amount of the resistance change of the platinum wire with the increase in temperature. The Figure 8 shown below represents the catalytic gas sensor. [16, 62]

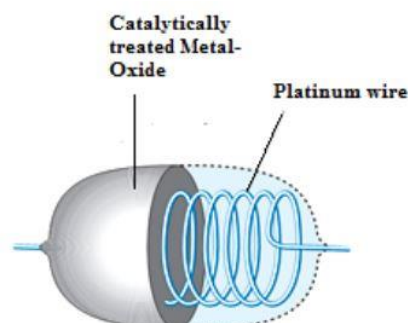

Figure 8. Catalytic gas sensor. Reprinted from [16, 62]

A Pellistor-Type catalytic gas sensor has active bead provided with catalyst like platinum and inactive bead free of catalyst. An external voltage supply is given to heat the coil and beads to the temperature needed for detection of the designated gas. In the presence of the flammable gas, the active bead gets oxidised and the temperature of the platinum wire increases which changes the electrical resistance of the wire connecting it but the inactive bead remains constant. This causes difference in the voltage of Wheatstone bridge from where the output of the sensor is taken.

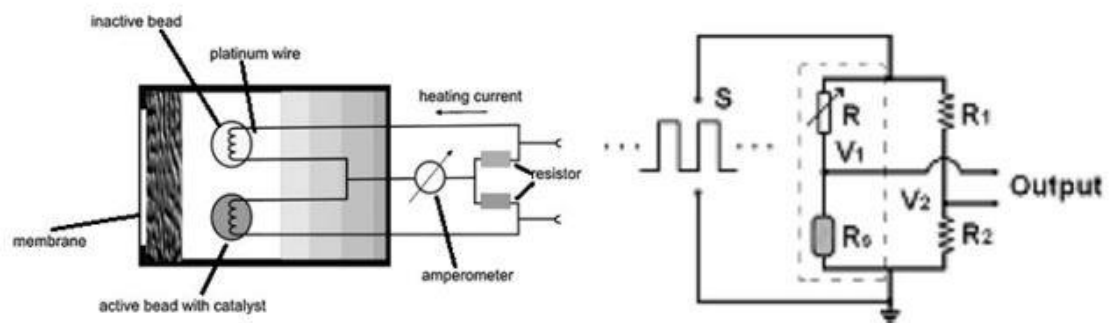

Figure 9: Pellistor- type gas sensor and Wheatstone bridge for methane gas detection.

Modified from [16, 63]

In the above Figure 9, ' R_s ' is the resistance of the active bead and ' V_1 ' is the variable resistors while ' R_1 ' and ' R_2 ' are fixed resistors. The resistor ' R_1 ' is adjusted to create stable equilibrium in the circuit in clean air. The resistance of ' R_s ' rises in presence of combustible gases and the equilibrium is disturbed which produces output voltage signal. This voltage signal determines the concentration of the gas in the air. Generally, methane gas is detected with this sensor. [16, 63]

Thermal Conductivity gas sensor

These sensors are used in detection of the gases only having higher conductivities than that of air. Its working principle is based on heat loss from hot body to cold body and works similarly like Pellistor-type gas sensor with Wheatstone bridge. When the resistor is exposed to the target gas, its temperature either increases or decreases depending on the nature of the gas. This causes change in resistor value and causes imbalance. Hence, the concentration of gas is determined like above sensor. Hydrogen gas can be detected with this sensor because they have high conductivity than air. [16, 64]

Electrochemical gas sensor

These sensors are made up of gas sensing electrode, a counter electrode and a thin layer of electrolyte between them. Then the target gases like carbon monoxide interact with the sensing electrode, it oxidizes through chemical reaction with water molecules of air and forming carbon dioxide and positively charged ion (H^+) which moves towards the electrolyte as shown below.

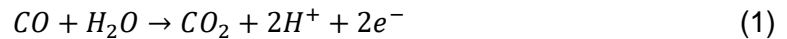

The above oxidation reaction is neutralised with reduction reaction with oxygen as shown below.



Hence, the carbon monoxide reacts with the air and diffuses into hydrogen ion which travels freely to electrolyte. This result of flow of hydrogen ion from the sensing electrode to the counter electrode generates an electric current which determines the concentration of the gas. Similarly, the hydrogen gas can be detected with this sensor by oxidation reaction followed by the reduction reaction as shown in chemical reactions 3 and 4 below.

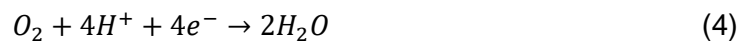
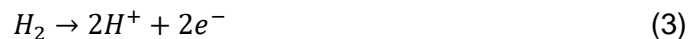

Generally, gases like Carbon dioxide and hydrogen are measured by this sensor. [16, 64-65]

Infrared gas sensor

This sensor contains infrared source and infrared detector which transforms the electromagnetic radiation energy into electrical signals. It detects gases like carbon dioxide, carbon monoxide and other hydrocarbons. The sensor also has optical fibre in it, and depending on the nature of this fibre, the infrared gas sensors are classified into dispersive and non-dispersive. Dispersive kinds are provided with optical devices such as

prism or grating while Non-dispersive uses discrete optical band-pass filter for gas identification. The sensor also has gas cell which acts as a medium for interaction of the light and the target gas. These sensors are widely used for carbon dioxide, hydrocarbons and alcohols. [16, 67]

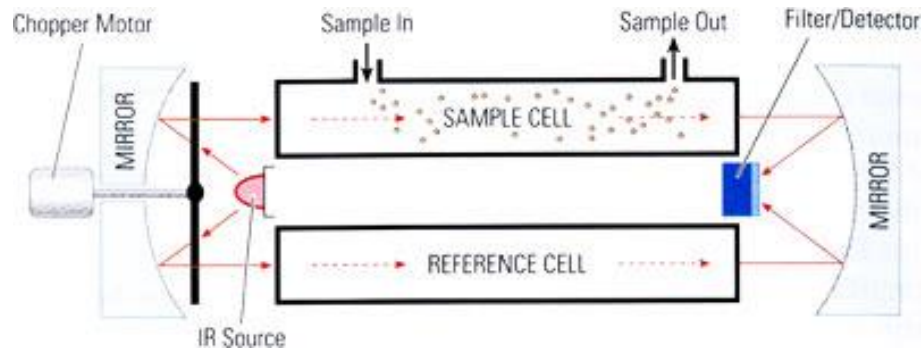

Figure 10: Infrared Sensor for gas detection. Reprinted from [17]

In the above Figure 10, the IR radiation is emitted by the IR source and it passes through the sample cell and reference cell after reflecting in the mirror and reaches the filter or detector. In the absence of the target gas, there is no disturbance in the wavelength of the received IR radiation. When the sample gas enters the chamber, it absorbs the IR radiation depending upon its nature and causes the reduction in the wavelength of IR radiation. Hence the detector notices the IR radiations with two different wavelengths at same moment. The difference in this wavelength determines the gas concentration. [17]

Semiconductor gas sensor

This type of sensor is built with the heated metal oxides that are used for the measurement of the concentration of the targeted gas by the variation in the electrical resistance of the sensor. The heater is made to reach the temperature of 200 to 250 °C to boost the chemical reaction. The principle of operation is reversible gas absorption at the metal oxide surface like tin oxide placed on a slice of silicon by chemical vapour decomposition method. Absorption of the gas due to catalytic reaction followed by reduction contributes in alternation of resistance which can be monitored by a device as shown in the Figure 11 below. For gases like hydrogen, oxygen, alcohols and carbon monoxides, which possesses reducing reaction properties, an intrinsic n-type semiconductor is used because of its high conductivity. The metal oxides for this material are generally SnO_2 , ZnO , In_2O_3 or WO_3 . On the other hand, the oxidizing gases are detected with the help of p-type semiconductor materials. [16, 67]

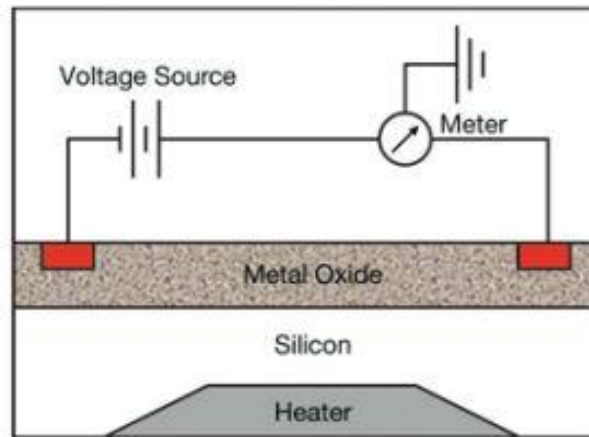

Figure 11: Semiconductor gas sensor. Reprinted from [16, 68]

The above Figure 11 represents the simple structure of the semiconductor gas sensor. When the gases with inflammable properties meet metal oxides, they excite a level of electron from its solid state and causes change in resistance of the gas sensing element. The sensitivity of the metal oxides can be increased by addition of small quantity of noble metals. [16, 68] The sensor used in this project, MQ-135 is semiconductor type of gas sensor.

3 Intelligent Nestbox

The intelligent nestbox is a box like structure designed for the habitation of the birds consisting of different scientific devices. The box can be made up of different metals, wood or concrete with a single or multiple holes which provide access to the nestbox. The box keeps the birds safe from extreme weather conditions as well as predators and contributes in their survival, feeding, reproduction and other life activities. The scientific equipment fixed with the box aid to monitor the changes in physical environment inside and outside the nestbox. With the help of intelligent nestbox, the users, bird-lovers or even ornithologists can gain various information about the different activities and behaviour of the bird inside the nestbox.

The intelligent nestbox in this project consists of the temperature sensor, humidity sensor, infrared sensor, air quality sensor and webcam. The simple structure of the nestbox is shown in the Figure 12.

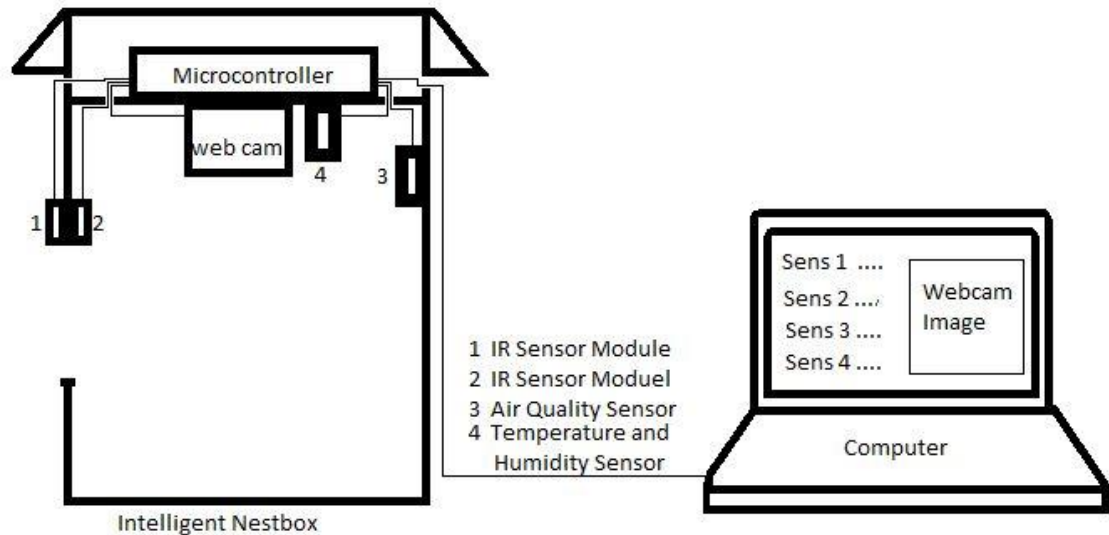

Figure 12: Intelligent Nestbox with Computer

3.1 Microcontroller

Microcontroller, popularly called as MCU (Microprocessor Unit) is self-sufficient system with single or multiple processors, memory storage and programmable input/output terminals designed for embedded applications. The automatic devices like remote controls, automobiles, household appliances, industrial machines etc. are widely operated by programmable microcontrollers. [18]

The microcontroller used in this project is Arduino Uno. It is a microcontroller board which is the recent version of USB Arduino board, based on ATmega328. It consists of 4 Digital Input/output pins among which 6 provides PWM output and 6 Analog Input pins. Also, it is provided with 16 MHz crystal oscillator, a USB connection, power jack, ICSP header and a reset button. The Arduino Uno microcontroller board is shown in the Figure 13 below. [19]

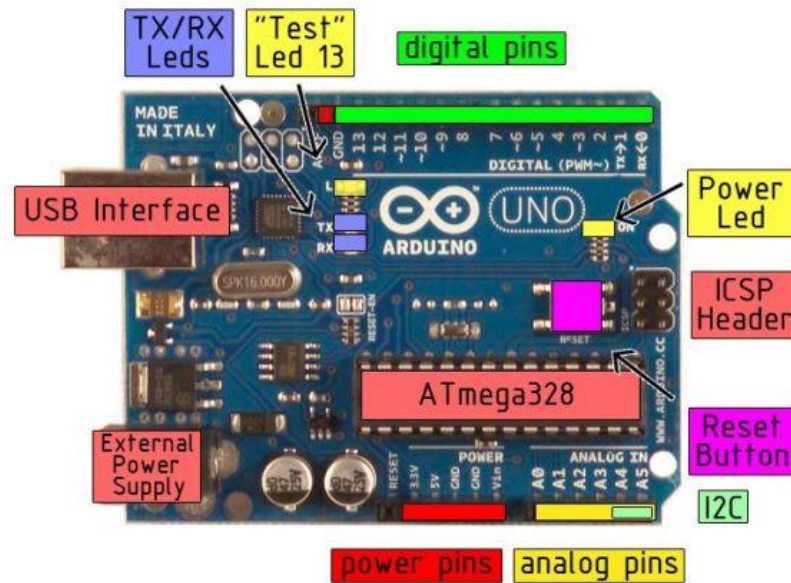

Figure 13: Arduino Uno Microcontroller. Reprinted from [19]

The Arduino Uno can be powered through USB connection or external power supply which may be AC-to-DC adapter or battery. It can be run by an external supply of 6 to 20 volts but the board becomes unstable if supplied less than 5V and overheated if given more than 12 V. Therefore, it is suggested to use power supply of 7-12 V.

There are four power pins, 'Vin' to which external voltage can be given, '5 V' which used to power up board and other components, '3.3 V' which is supply voltage generated by board with current drawing capacity of 50 mA and ground pin 'Gnd'. The microcontroller ATmega328 possess flash memory of 32 Kb for storing programming codes and 2 KB of SRAM and 1 KB of EEPROM. [19]

Each analog input pins among 6 provides 10 bits of resolution, i.e. 1024 different values. Two special pins 'A4' and 'A5' supports I²C communication using wire library. On the other hand, 'AREF' gives reference voltage to analog inputs and Reset button is used for resetting microcontroller board.

The 14 digital pins can be used an input or output with functions 'pinMode()', 'digitalWrite()', and 'digitalRead()'. They can gain or administer 40 mA current and contains 20-50 kOhms of in-built pull-up resistor and functions at 5 V. Some specialized digital pins are:

- Serial: 0(RX) and 1(TX) are used to receive and transmit TTL serial data respectively.
- External Interrupts, 2 and 3: these pins are used for triggering an interruption on low value, ascending or descending edge, or any alternation in value.
- PWM: the pins 3, 5, 6, 9 and 11 are for 8-bit analog output with '`analogWrite()`' function.
- SPI (Serial Peripheral Interface) pins: 10, 11, 12 and 13 supports SPI communication which are not included in Arduino Language at present.

The built-in LED pin connected to pin 13 indicates high or low value by blinking and Power LED illuminates when the power is supplied to board. [19]

3.2 Sensors

3.2.1 TMP36

The outer environment of the nestbox was measured using TMP36 sensor which is very cheap, convenient and provides consistent temperature readings. In contrast to temperature sensors like thermometer, thermistors and bimetallic strips, their temperature is dependent on the voltage drops across the base and emitter (V_{be}). All the complicated calculations are done inside the chip which makes the temperature measurement very convenient. The temperature is directly proportional to the change in voltage which is generated as Analog signal. They are durable, calibrated to give measurement in °C and stays strong against harsh environmental conditions. The Figure 14 below indicates the TMP36 sensor. [20]

3.2.2 DHT22

To execute the task of determining the temperature and humidity inside the nestbox, different sensors available in the market were checked and concluded with DHT22, also called as AM2302. It uses thermistor for temperature measurement and the relative humidity is measured by capacitive means. Both values are fine-tuned, delivered via a digital 1 wire communication line. The sensing elements, Polymer capacitor are bridged up with 8-bit single-chip computer. The sensors associated with this module are calibrated in authentic calibration chamber and points out the coefficient from calibration-coefficient which is stored in one form of programme in OTP memory during operation. [23]

The sensor draws 3.3-6 V DC power and operates in the range of 0-100 % relative humidity and -40~80 °C. Its highest sampling rate is single measurement in every 2 second. If this condition is disrupted, result may be delivered incorrectly. Due to its low power consumption, convenient size, 4 pins packaged in single row, accuracy of ± 2 % humidity and ± 2 °C temperature, it became our best choice. The structure of DHT22 sensor is shown in Figure 16 below. [23]

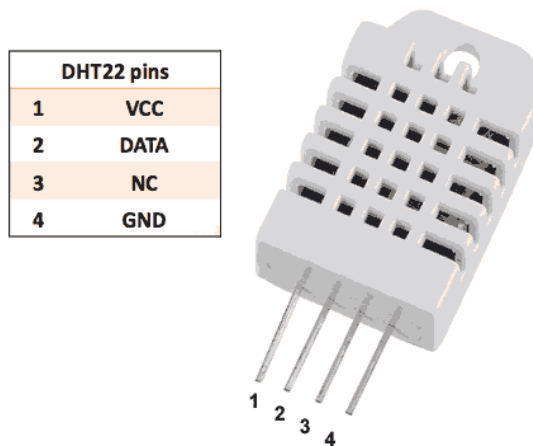

Figure 16: DHT22 / AM2302 sensor. Reprinted from [24]

Communication and Signal

MaxDirect 1-wire bus data format is used for communication. A data transmission is 40bit, consisting of integral and decimal part.

DAT = 8-bit integral RH data+8-bit decimal RH data+8-bit integral T data+8-bit decimal T data+8-bit check-sum. When check-sum is equal to last 8-bit of "8-bit integral RH data+8-bit decimal RH data+8-bit integral T data+8-bit decimal T data", the transmission is correct. [23]

The protocol regulates the value of conducted bit by the duration of upper level on the data line. Initially, the bus is pulled to elevated level. The MCU starts the transmission by pulling the line low for 1-10 ms and then again pulls back high for 20-40 μ s and waits for the sensor response. These sensors accept the starting signal by pulling the line to low and again back to elevated level, both for 80 μ s. Then the data transmission process starts. Each bit's communication starts with low-voltage level lasting for 50 μ s, followed by high-voltage-level whose length concludes the bit to be "0" or "1". If the time period of high level is around 26-28 μ s, the sensor outputs 1 bit data of "0". On the other hand, the time period of 70 μ s interprets 1-bit data of "1". The sensor pulls the line to low level to indicate the end of latest bit's high period and releases the line. The microcontroller then pushes line upward to high level to announce the accomplishment of transmission process. The overall transmission process is indicated by the Figure 17 below. [23]

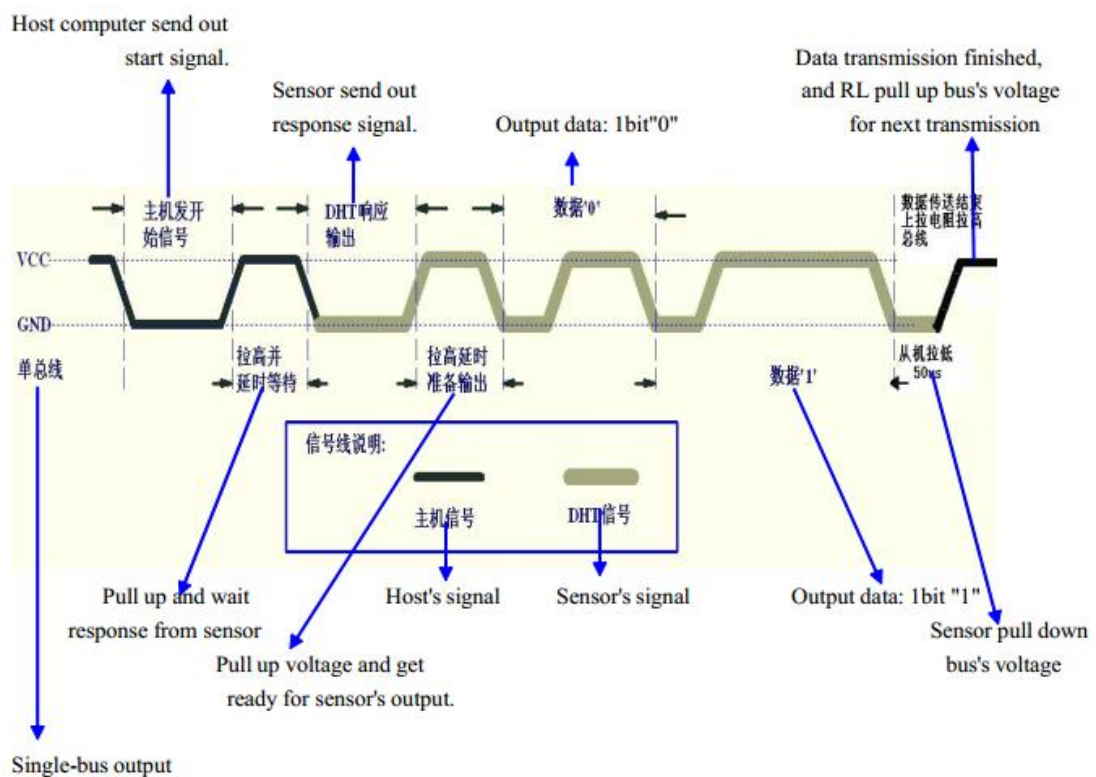

Figure 17: Overall transmission process. Reprinted from [25]

3.2.3 IR Sensor Module

To study about the number of times bird makes entry and exit inside the nestbox, the IR sensor module is used. This sensor module is very popular, widely used and based on the principle of reflection of infrared rays from the incident surface. The basic component of this module are IR LED and photodiode where photodiode senses the IR light of certain reflected frequency, emitted by the IR LED.

The position of the IR LED, an infrared transmitter and photodiode, an infrared detector can be direct and indirect as shown in the Figure 18 below.

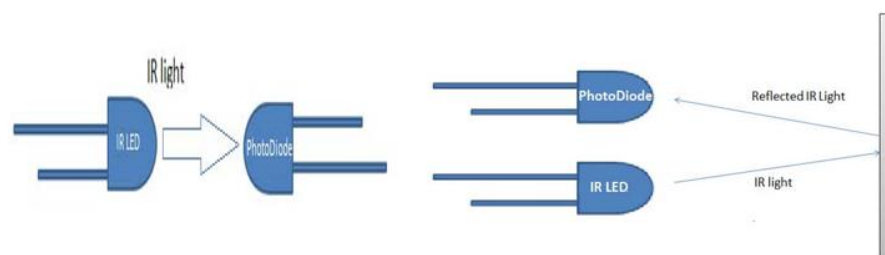

Figure 18: Direct and Indirect Positioning. Reprinted from [24]

The basic components of this module are listed below.

IR LED

This emits the infrared light with wavelength in the range of 700 nm-1 mm. These lights are higher than the visible light range and thus invisible to us. The IR LED has similar appearance and operates like normal LEDs. It has light emitting angle up to 35 degrees and draws 3 Volts power and 20 mA current. The range of IR LED varies from few centimetres to 30 centimetres. This depends on the distance adjuster of this module. [27]

Photodiode

These are Light Dependent Resistor (LDR) whose resistance decreases with increase in the incident light intensity. It looks like LED but with black colour. It is a semiconductor having p-n junction diode operating in Reverse Bias which starts conducting current in opposite direction when light falls on it. The current flow is directly proportional to amount of light. [27]

Operational Amplifier (LM393)

The operational amplifier included in this module is LM393 used as voltage comparator. It contains two voltage comparators, among which only one is used. It compares two inputs, inverting (Pin 3) and non-inverting (Pin 2) and gives the output (Pin 1) indicating which one is larger. In this module, when the inverting input is higher than non-inverting input, the output of comparator is HIGH. On the other hand, if inverting input is higher, the output is LOW. [26]

Distance adjuster:

The distance adjuster is just a simple potentiometer of value 10 kOhm. The range of the distance, up to 30 cm is determined by turning knob of it into clockwise or anti-clockwise direction. The clockwise turning increases the range of detection whereas anti-clockwise results in reduction.

Also, the module contains Power LED which glows when supplied with power and Obstacle LED which illuminates when certain obstacle or disturbance is detected. The Pins Vcc, Gnd and Out represents the DC Input of 3.3 to 5 volts, Ground and Output which goes LOW when obstacle is detected. The dimension of the sensor module board is 3.2 cm x 1.4 cm. [27]

Operation of this module

The Photodiode is connected in reverse bias. The inverting end of LM393 (Pin 2) is connected with distance adjuster to adjust ranger of detection and non-inverting end (Pin 3) is connected to junction of resistor and photodiode as shown in Figure 19 below.

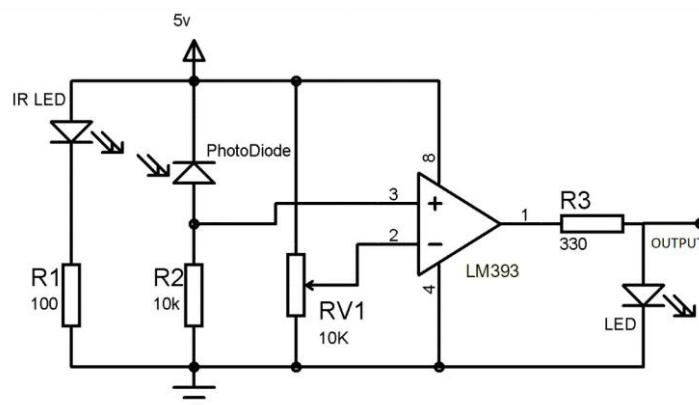

Figure 19: IR sensor module circuit diagram. Modified from [26]

When the circuit is powered with input voltage of 3.3 to 5 volts, the IR radiations emitted by IR LED does not reach the photodiode and hence the output of the comparator is LOW. When the obstacle is put in front of the Photo couple, the IR radiations reflect to photodiode and the voltage across photodiode drops which causes voltage across the resistor R2 to increase. Since it is connected to non-inverting end of comparator LM393, the higher value of voltage across R2 gives HIGH output and obstacle LED illuminates. The voltage at inverting end, called as Threshold Voltage can be fixed by rotating the knob of distance adjuster. The high voltage at inverting end (-) makes sensor less sensitive and vice-versa in case of non-inverting end. [26]

3.2.4 MQ-135

It is a semiconductor air quality sensor possessing small heater and SnO_2 as a sensitivity material which has very low conductivity in clean air. They exhibit strong sensitivity towards Ammonia, Alcohol, Benzene, Sulphide, smoke and other gases. The conductivity increases with increase in concentration of the gases in the air. The dual output signals, analog and digital determines the presence of gases. The digital output signal value can be read by microcontroller's digital input pin whereas the analog output signal i.e. analog voltage value directly proportional to the rise in concentration of the harmful gases can be accessed by analog input pins. Due to its reliable stability, rapid response recovery properties, durability and wide range of detection, it can be used as for pollution detector. [28]



Figure 20: MQ-135 sensor. Reprinted from [29]

This sensor shown in Figure 20, operates with 5 V AC or DC power supply which can also be used for heater included inside. The heater resistance is about 33 Ohms and draws less than 800 mW power at standard room temperature. The load-resistor of value

10 kOhm to 47 kOhm is connected at output to the ground. The lower value of this resistance makes sensor less sensitive but the higher value makes the sensor's accuracy decline in large concentration of gases. This plays very important role in detection of the concentration of certain gas in air. For air quality sensor, the load resistor value can be chosen in such a way that the analog output voltage delivered is about 1 V in clean air. The sensor should be heated for 24-48 hours for exact determination of the load resistance value. [28] The structure and configuration of MQ-135 is shown below.

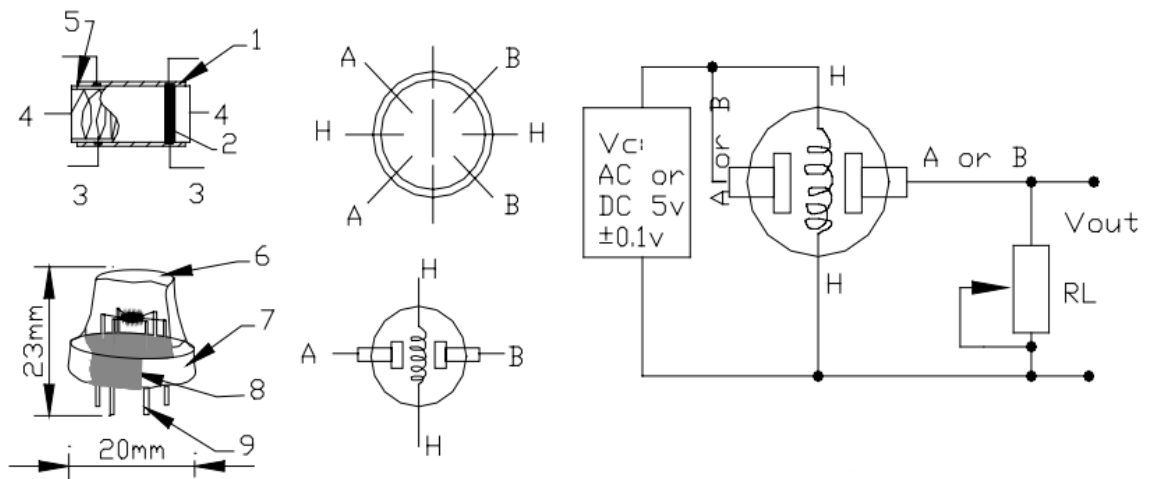

Figure 21: Structure and Configuration of MQ-135. Modified from [28]

In the above diagram, the gas sensing layer made up with SnO_2 , Electrode, Electrode line, Heater coil, Tubular ceramic are represented by 1, 2, 3, 4 and 5 respectively. Similarly, 6, 7, 8 and 9 indicates the Anti-explosion network, Camp ring, Resin base and Tube Pin. The sensor MQ-135 has 6 pins among which 4 provides the output signals and remaining two are provides the heating current. [28]

Cheap price, easy installation, low voltage operation and long durability quality made it suitable for this project.

3.3 Web Camera

To fulfil the aim of monitoring the bird and their activities inside the nest, a simple, cost efficient and high performance web camera which could be interfaced with LabVIEW was needed. These requirements were fulfilled by 'Logitech HD webcam C525', used as general webcam with computers in our homes which is shown in the Figure 22 below.



Figure 22: Web camera. Reprinted from [31]

This webcam can be simply connected to USB port of Computer/Laptop installed with 32 or 64-bit Windows Operating System. It is capable of video (1280 x 720 pixels) and photo (8 megapixels) capture at high speed and provided with advanced specifications like face tracking, motion detection and autofocus. It is portable and installation process is very simple. [30]

Other minor components used in this project are breadboard, jumper wires, connecting wires, LEDs, resistors, connecting cables etc.

4 Software

4.1 Arduino IDE

This is a cross-platform application where the program or code is written, compiled and uploaded to any Arduino hardware devices. This software can be easily installed in any computer devices to work offline. In addition to it, online version is also available which enables the user to enjoy the latest version of it without worrying about any updates or need of installing separate libraries for performing designated task. It supports the languages C and C++ with certain boundary for code structuring. [32]

The programs created in this platform are called sketches and can be saved with file extension.ino. This program contains two main functions, `setup()` and `loop()`. `setup()` initialize the input/output pin nodes, variables and other libraries of the sketch while `loop()` repeatedly performs the main program until the board is powered off or

reset. When the program is compiled and uploaded to the hardware device, the result can be observed in the serial monitor. [32]

Also, there are certain libraries which offer additional functionality for the sketches to work with the hardware or to play with the input data. They are included with `#include` statements on the head of the sketch and compiled together with the code. This project contains two libraries, 'DHT Sensor library' and 'Adafruit Sensor Library' which converts the digital value sent by DHT22 sensor into readable temperature and Humidity value.

4.2 LabVIEW

LabVIEW (Laboratory Virtual Instrument Engineering Workbench) is a software developed by National Instruments which is extensively used across various fields and industries for different purposes which may be theoretical demonstration, research projects or industrial testing and control systems. It is very accommodating in the field of science and engineering because of its capability to generate custom applications which relates with the real-world data or signals. [33]

The LabVIEW software platform is very energetic. It can manipulate the equipments and collect the result data. It also includes the extensive analysis on signal processing capabilities and enabling the results to be processed and looped back to repeat the actions with slightly different action limits so the conditions can be enhanced or exact monitoring can be done. These large capabilities are accomplished within a simple environment via Graphical Programming methods which makes the scientists and engineers to run complicated routines comparatively smoothly. In this G-Programming language (Graphical Programming language), there are numerous images which indicates the different functions in programme which could be placed in desired order and can be wired to execute the programme in anticipated way. [33]

LabVIEW supports different hardware devices like Sensors, Cameras, Microcontrollers, Data acquisition devices and other scientific instruments. They also include the libraries having special functions for signal generation, processing and analysis, mathematics and statistics, data acquisition and many more. Textual programming languages like ANSI C/ C++, VHDL etc. can be also used in LabVIEW. [33]

The hardware components of this project are interface with LabVIEW for final result analysis. Real-data generated by the sensors are processed by the microcontroller and are presented in the LabVIEW with the help of Visa Serial Port but it is not applicable in case of camera. Hence, separate driver had to be installed for generating images from webcam, called as Vision Acquisition Software.

Vision Acquisition Software

This software allows to generate, display and save images from multiple cameras in LabVIEW and works with all the smart cameras. It has NI-IMAQ driver which helps to take pictures from digital cameras and smart cameras. Also, it is provided with NI-IMAQdx driver which acquires images from USB device cameras like USB3Vision camera and IP cameras. [34]

The webcam used in this project can be interfaced with LabVIEW with the help of this software.

4.3 Webcam.

The UVC drivers are automatically installed in the computer connected with the internet when the webcam is introduced into it. [30]

5 Physical Implementations

TMP36

The connection procedure of TMP36 is very simple. The Vcc pin of the sensor is connected to 5 V pin of microcontroller. 3.3 V can also be used for this sensor because the output is independent of the input supply power. Similarly, the ground pin is appended with ground pin of Arduino board and output pin of the sensor is hooked up to Analog pin A0. Since the sensor is Analog, no libraries are required for it. The microcontroller simply can read the voltage value from the sensor. Few calculations are included in the programming section to change the voltage value into temperature scale.

When using a 5 V value, the 10-bit analog reading is converted to temperature as shown in equation 5.

$$\text{Output voltage from pin A0 in millivolts} = \frac{\text{Readings from ADC} \times 5000}{1024} \quad (5)$$

This equation 5 transforms the number 0-1023 from the ADC into 0-5000 mV (5 V). This value is converted to temperature by using the equation 6. [7]

$$\text{Temperature in centigrade} = \frac{\text{Output voltage (mV)} - 500}{10} \quad (6)$$

Then the programming code, which is shown below in listing 1 is fed to the microcontroller and the result is viewed in serial monitor.

```
int sensoroutput = 0;
void setup()
{
  Serial.begin(9600);
}
void loop()
{
  int reading = analogRead(sensoroutput);
  float voltage = reading * 5.0;
  voltage /= 1024.0;
  Serial.print(voltage);
  Serial.println(" volts");
  float tmpC = (voltage - 0.5) * 100;
  Serial.print(tmpC);
  Serial.println(" C");
  float tmpF = (tmpC * 9.0 / 5.0) + 32.0;
  Serial.print(tmpF);
  Serial.println(" F");
  delay(1000);
}
```

Listing 1: programming code for TMP36 sensor.

In Listing 1, the output integer voltage of the TMP36 is obtained from the analog pin A0. The attained value is in millivolts. The function `setup()` runs when the microcontroller is turned on and makes serial connection with the computer so that the result can be observed. The function `loop()` runs the task repeatedly. Inside the loop, `int reading` reads the voltage value of the sensor which is converted to the voltage and printed by `Serial.print()` function. Also, the `float tmpC` and `float tmpF` converts the

voltage value into degree centigrade and degree Fahrenheit respectively and displayed by `Serial.print()` function again. The interval of the loop operation is controlled by `delay()` function. The integer value inserted in the delay function denotes milliseconds.

DHT22

The DHT22 has 4 pins; Vcc is connected to 3.3 or 5 V port of Arduino board, the second pin gives output which is connected to Digital (PWM) input port 2, the third pin has no significant role so it is ignored and the last pin is connected to the ground. The external resistor of 10K is connected between Vcc and Output pin to facilitate in pulling up the data line. Although the Arduino has in-built pullups, they are ineffective.

To initializing the sketch for DHT22, a library called 'DHT Sensor library' is needed which can be downloaded from GitHub repository. 'Adafruit Sensor Library' is also installed to facilitate this library. It encloses the class DHT22 which can be used without making any changes. The sketch for operation is found in example section, inside DHT, named as DHT tester. With minor modification in it, the sensor performs the task in desired way.

```
#include <DHT.h>
#include <DHT_U.h>
#define DHTPIN 2
#define DHTTYPE DHT22
DHT dht(DHTPIN, DHTTYPE);
void setup()
{
  Serial.begin(9600);
  dht.begin();
}
void loop()
{
  float h = dht.readHumidity();
  float t = dht.readTemperature();
  Serial.print("Humidity");
  Serial.print(h);
  Serial.print("\t");
  Serial.print("Temperature");
  Serial.print(t);
  Serial.print("\t");
  Serial.print("Fahrenheit");
  Serial.print(tf);
  Serial.print("\n");
  delay(2000);
}
```

Listing 2: Programming code for DHT22 sensor

In Listing 2, the two libraries, DHT Sensor Library `<DHT.h>` and Adafruit Sensor Library `<DHT_U.h>` are included so that the reading from the output pin of the sensor is directly changed into the temperature and the humidity value. The port of the Arduino and the humidity sensor type is defined by `#define DHTPIN 2` and `#define DHTTYPE DHT22`. The `setup()` function does the same function as described in listing 1 and the loop is initialized by `loop()` function. The functions `dht.readHumidity()` and `dht.readTemperature()` gives the humidity and temperature reading as X % relative humidity, X °C temperature and X °F temperature where X represents the float value. These values are printed by `Serial.print()` function. The sensor is capable of reading measurements at interval of 2 seconds only, and hence the `delay()` function is maintained accordingly.

IR sensor module as counters:

The two IR sensor module is first tested individually before using it to make two-way counter for nestbox. The Vcc and Gnd pin are connected to 5V and ground port of Arduino. Similarly, the Output pin is linked to Digital (PWM) Input ports 7 and 8. The sensors must work in such a way that it can count the number of times bird enters and leaves. The code is then fed to the Arduino to obtain the desired output.

Both sensors work continuously and sense the presence of any obstacle. When sensor1 detects any obstacle, then the information is sent to the microcontroller and the programme converts the information to increment in the entry. At the same time, it provides the delay of 1 second so that the obstacle (say bird) can cross the sensor2 and smooth count is maintained.

Again, when sensor2 detects any disturbance, it informs the microcontroller and the programme changes disturbance into increase in exit. The delay of 1 second is maintained in this case so that the disturbance (say bird) can cross sensor1 and does not affect the counting. The codes for the operation of the sensors is shown below.

```

int total=0;
int total1=0;
void setup()
{
  pinMode(8, INPUT);
  pinMode(7, INPUT);
  Serial.begin(9600);
}
void show()
{
  Serial.print(total);
  Serial.println("Entry.");
  Serial.print(total1);
  Serial.println("Exit.");
}
void loop()
{
  if (digitalRead(7) == LOW){
    while (digitalRead(8)== HIGH){
    }
    total++;
    delay (1000);
  }
  else if (digitalRead(8) == LOW) {
    while (digitalRead(7)== HIGH){
    }
    total1++;
    delay (1000);
  }
}
}

```

Listing 3: Arduino codes for IR sensor module as counter

In Listing 3, the two needed integer values as entry and exit are defined by `total` and `total1`. The output of the two IR sensors are defined to be taken from digital pins 7 and 8 of Arduino. The function `show()` helps to display the integer value of each entry and exit. Functions `loop()` and `setup()` has similar task as mentioned in listing 1 and listing 2. Inside the loop, the `if()` statement indicates the count of sensor connected to pin 7 (sensor1) when the digital port 8 value is `HIGH`. On the other hand, the `else if()` statement displays the count of sensor value from pin 8 (sensor2) when the Arduino port 7 is `LOW`. The `LOW` value adds 1 whereas `HIGH` value makes integer constant. The `delay()` function provides time for operation of both sensors.

MQ-135

The connection is done as shown in Figure 20, the two pins 'A or B' and one 'H' pin is linked together to 5 V of Arduino board and another 'H' pin is connected to the ground. Remaining two 'A or B' pins for output are joined together to get the output voltage and a load resistor i.e. potentiometer of value 20-47 kOhm is connected between it and the ground.

The sensor is used in such a way that only analog voltage value can be obtained from it. Further processing of this voltage for the air quality observation is done in LabVIEW by keeping different referencing point. The simple programming code is shown below

```
int analogVoltage;
void setup()
{
  Serial.begin(9600);
}
void loop()
{
  analogVoltage = analogRead(1);
  Serial.println(analogVoltage, DEC);
  delay(100);
}
```

Listing 4: Arduino code for obtaining analog voltage value of sensor

In listing 4 shown above, the integer for analog voltage value is defined. The functions `setup()` and `loop()` has same significance as in above listings. The analog voltage is generated from the analog pin A1 of the Arduino board and the value is printed by `Serial.println()` function with whereas `delay()` function determines the interval of every loop.

Webcam interface with LabVIEW

The webcam is connected to one of the port of the computer and is interfaced with the LabVIEW. For this process, the port number is mentioned in the Port Section in the front panel of the VI created for live display and saving of images.

6 Testing

6.1 Accuracy testing

To determine the performance of the components with microcontroller, the sensors TMP36 and DHT22 were tested in Environmental Chamber of Albertinkatu Campus. In the Figure 21 and Figure 22 below, the blue line indicates the temperature or humidity inside the chamber and yellow line indicates the value shown by the sensor.

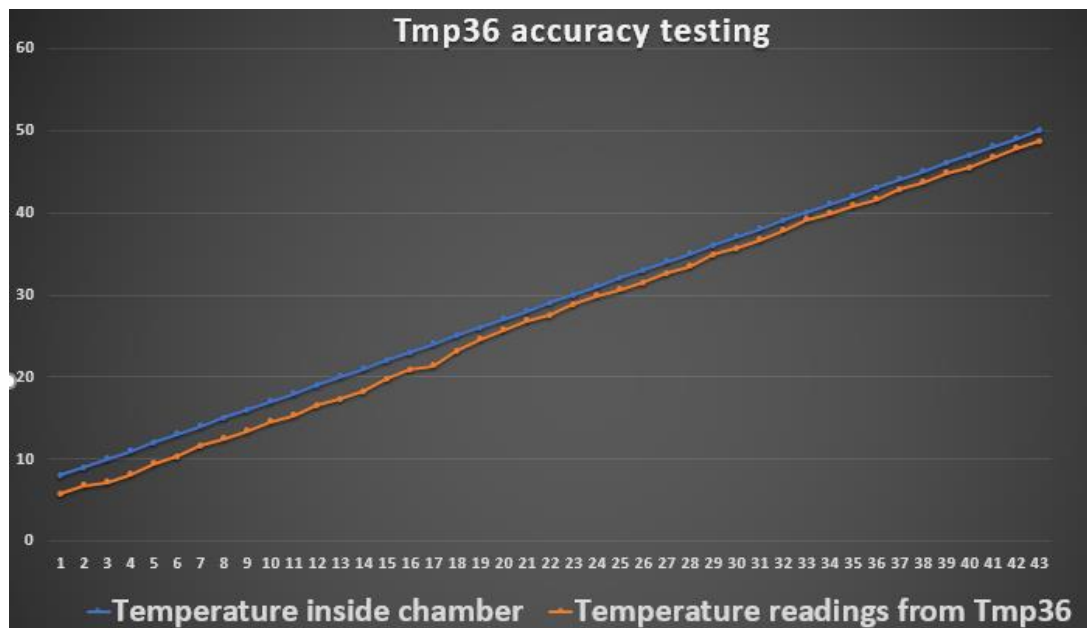

Figure 23: Tmp36 accuracy testing

In the Figure 21 above, the blue line indicates the temperature inside the chamber and yellow line indicates the value shown by the sensor. TMP36 demonstrated the accuracy as mentioned by the manufacturer. The accuracy was below $-2\text{ }^{\circ}\text{C}$ over the temperature $25\text{ }^{\circ}\text{C}$.

Similarly, DHT22 was introduced inside the chamber and the temperature and humidity measurement was taken, which displayed the temperature accuracy in the range of $\pm 2\text{ }^{\circ}\text{C}$ and Relative Humidity of $\pm 2\%$ as mentioned by datasheet.

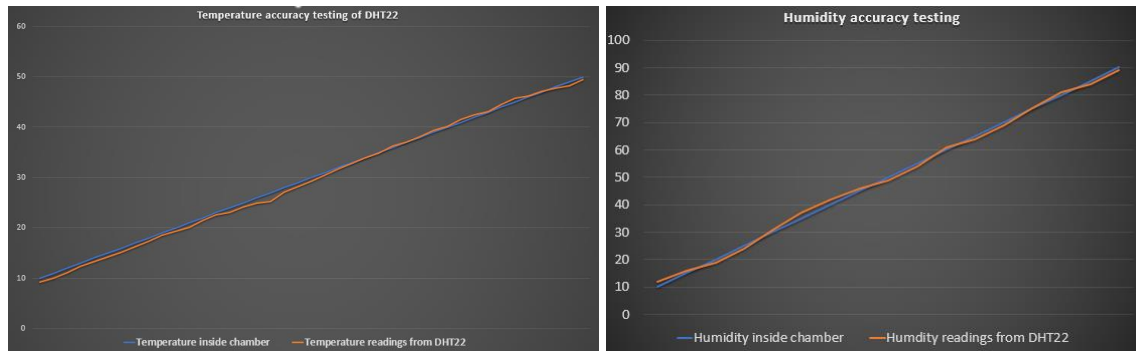

Figure 24: DHT22 temperature and humidity accuracy testing

On the other hand, the range of IR sensor module was tested by measuring the obstacle distance detection. The disturbance was identified within the range of 28cm only which is still less than 2 cm as mentioned by the datasheet of manufacturer. The interval of identification could be controlled through microcontroller. It was found during the testing that too bright external light (sunlight and other room lights) affected the sensor. The infrared emitted get reflected without the presence of any obstacle due to these light is reason behind. In such cases, the distance adjuster is tuned so that only disturbance reflects the emitted radiations.

Likewise, the air quality sensor MQ-135 was heated for 12 hours in fresh air. The analog voltage value was observed to be around 430-500 mV. This indicates that the sensor delivers output voltage in the range of 430-500 mV in clean/fresh air which is almost half of the value mentioned by the manufacturer. The reason behind this is the value of potentiometer used with air quality sensor. Since the sensor was used just to set reference point for the change in quality of air, the value above 500 mV was considered as polluted or hazard.

Finally, all the sensors were connected as described above, the modifications to the main code (Appendix 1) was done and the results were observed in the serial monitor of Arduino IDE. All the sensors worked as expected and the Arduino was interfaced with the LabVIEW for systematic representation of different outputs of the sensors as well as webcam video.

6.2 Testing with LabVIEW

After the accomplishment of accuracy testing, the results were then needed to be displayed systematically in LabVIEW. For this purpose, the VI is created for acquiring the characters seen on the serial monitor after uploading the main code to the microcontroller board (Appendix 2). Similarly, another block diagram, shown in Appendix 3, is created for live video observation in the LabVIEW. The front panel of the resulting block diagram appears as shown in Figure 25.

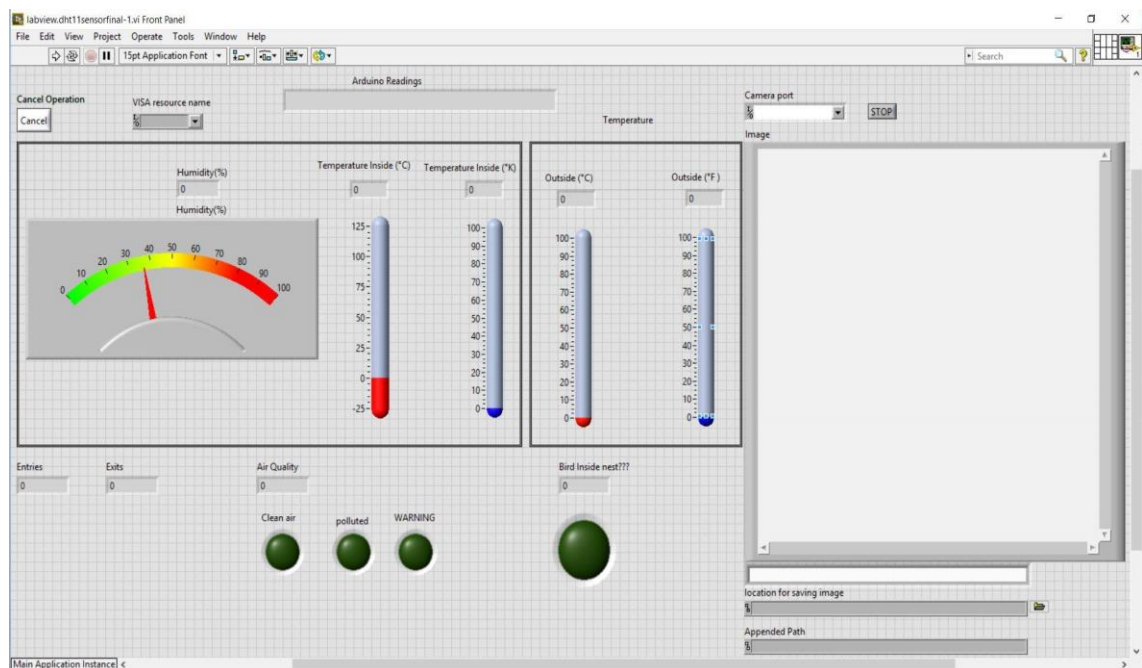

Figure 25: LabVIEW front panel for displaying results

In the above Figure 25, the raw values seen in serial monitor is displayed in '*Arduino Readings*'. The port in the computer or laptop, where the microcontroller is connected, is chosen in '*Visa resource name*'. In the same manner, '*Camera Port*' enables to choose the port in which webcam is connected and the video is displayed in white box seen below '*Image*'. The images can be saved continuously in increasing order of number by defining the path for saving with the help of '*location for saving image*' VI. There are symbols of thermometer for indicating the temperature inside and outside the nestbox, a meter for indicating the value of humidity in percentage between 0 and 100, separate boxes for indicating the number of entries, exits, air quality as well as bird inside. The three indicators '*Clean air*', '*polluted*' and '*Warning*' glows to represent the quality of air inside the nestbox. Also, the indicator is placed to display to see if the bird is inside or

not. The reason for doing so is that the web camera can be turned off if there is no bird inside.

Lastly, positioning of the components are done roughly and the LabVIEW programme is operated. The results can be seen in the corresponding places as shown in Appendix 4.

7 Installation and Observations

Finally, the built system was installed in simple nest looking prototype. The Temperature sensor "TMP36" and one IR sensor which indicates the entry of the bird was kept outside of the nestbox 8 (Appendix 6). The remaining Humidity/Temperature sensor "DHT22", air quality sensor "MQ-135", IR sensor for counting exits and Camera for monitoring the bird are kept inside the nestbox (Appendix 5). The Microcontroller was kept outside and connected with the sensors and camera with the very thin wires. Connecting wires were aligned as smoothly as possible and position of sensors were chosen in such a way so that there won't be any difficulty for the bird during its stay and movements. Positioning of the components were done in such a way which could not be easily affected by any external disturbances.

8 Functionality Testing and Discussions

For the testing of the functionality of the system, the main programme (Appendix 1) for all the sensors were uploaded to the microcontroller and it was interfaced with LabVIEW. Then warm air was blown inside the nestbox through small hole using Hair dryer and applied cold ice packed in plastic bag to the temperature sensor outside. It was noticed that the humidity level inside the box decreased and the value of temperature rose. In like manner, the temperature value of sensor outside was decreased. On top of it, one small ball was introduced inside the box through hole and took it out and found the IR sensors working perfectly as counters. Finally, burning matchstick was inserted inside the nestbox and detected the increase in analog voltage level which indicated the disturbance in the air quality inside the box.

All these activities were observed by the camera and were displayed on our computer screen. The sensors gave their best performance when they were run for long hours,

instant switching on and off affected their accuracy on measurement. The project was more focussed on live observation than having a memory card installed with it to study it later. For this purpose, the system needs to be connected to the PC all the time. However, the pictures of the birds could be snipped and saved continuously with the help of LabVIEW.

9 Future possibilities of Intelligent Nestbox.

This project Intelligent Nestbox can be foundation tool for the research purpose on the birds as well as other animal species. Extension of the modern technologies, hardware and the modifications to the software would enable the system to monitor many other physical and biological aspects of life of birds as well as other tasks. The further modifications on this nestbox might bring significant improvement which may include online video transmission, Wi-Fi connectivity, and audio recording and self-operation settings depending on the intensity of the indoor and outdoor lightings. In addition to it, physical environment can be altered for the adjustment of the bird's habitat by introducing extra physical components. For example, light intensity can be altered if needed, temperature and humidity can be balanced as per need.

Thus, the system could be applied to other birds, mammals, reptiles and other animals using nest boxes for their breeding, hibernating, food storage to monitor and understand the effect of the environment on their feeding habit, parental care, sibling competition and other activities of life. It can be expected that this nestbox will provide different perspectives of cave-dwelling animals.

10 Conclusion

The aim of this project was to design a smart system for nestbox with different sensors and camera which could facilitate in study of the physical environments of the nestbox and observe the activities of the bird inside it. To conclude this task, the system must show high performance of the sensors and cameras and long term measurement.

During this project, various difficulties were encountered and most of them were solved. Therefore, the system is still a prototype and a few improvements would turn it into a polished and final product. Despite of lacking certain features, it is as functional as we expected. The testing of complete system couldn't be done in real environment with the birds because it would be time consuming. Nevertheless, the prime goal was successfully achieved.

Considering the improvements, back to back recording of the information can be made by using memory devices instead of PC which helps in reduction of power consumption and makes it cost friendly. Special programme can be made for the sensors calibration, as well as making system active only at the time of need can improve the efficiency of the system. Fine placement of connecting wires in the nestbox can contribute in access of bird to it. Wi-Fi module can be added to it to make study more accessible and circuit board can also be designed for easy installation of the system.

References

- 1 Kuorosh Kalantar-zadeh. Sensors. An Introductory Course. 2013
- 2 Temperature. [online]
<https://en.wikipedia.org/wiki/Temperature>
Accessed November 5, 2016
- 3 Hank Zumbahlen. Editor. Linear Circuit Design Handbook. Sensors. Published by Newnes/Elsevier, 2008, ISBN-978-0-7506-8703-4 [online]

URL:<http://www.analog.com/media/en/training-seminars/design-handbooks/Basic-Linear-Design/Chapter3.pdf>
Accessed November 3, 2016
- 4 Temperature Sensors. [online]

URL: http://link.springer.com/chapter/10.1007%2F978-1-4419-6466-3_16
Accessed November 6, 2016
- 5 Justin Austin. Commentator. Challenges and solutions for thermocouple signal conditioning. 06/16/15 [online]

URL:<https://www.ecnmag.com/article/2015/06/challenges-and-solutions-thermocouple-signal-conditioning>
Accessed on October 6, 2016
- 6 Thermocouple VS RTD VS Thermistor. Difference between Thermocouple, RTD and Thermistor [online]

URL:<http://www.rfwireless-world.com/Terminology/Thermocouple-vs-RTD-vs-Thermistor.html>
Accessed on December 6, 2016
- 7 How does the thermistor "read" temperature? [online]

URL: <http://www.teamwavelength.com/info/thermistors.php>
Accessed on December 6, 2016
- 8 Introduction to Semiconductor Temperature Sensors. [online]

URL: <http://www.capgo.com/Resources/Temperature/Semiconductor/Semi.html>
Accessed on December 6, 2016
- 9 Preeti Jain. Writer. Humidity Sensor. [online]

URL: <http://www.engineersgarage.com/articles/humidity-sensor>
Accessed on September 12, 2016

- 10 Humidity Sensors. Overview and History. [online]
URL:<http://au.rs-online.com/web/generalDisplay.html?id=infozone&file=automation/humidity-sensor>
Accessed on December 14, 2016
- 11 Robert Repas. Editor. Sensor Sense: Humidity Sensors. Nov 9, 2009 [online]
URL: <http://machinedesign.com/news/sensor-sense-humidity-sensors>
Accessed on December 15, 2016
- 12 Modern Hygrometers. [online]
URL: https://en.wikipedia.org/wiki/Hygrometer#Modern_hygrometers
Accessed on December 16, 2016
- 13 Alexander Chilton. The Working Principle and Key Applications of Infrared Sensors. Oct 15, 2014 [online]
URL: <http://www.azosensors.com/article.aspx?ArticleID=339>
Accessed on October 15, 2016
- 14 Preeti Jain. Infrared Sensors or IR sensors. Types and applications. [online]
URL: <http://www.engineersgarage.com/articles/infrared-sensors?page=1>
Accessed on October 17, 2016
- 15 Sensor Technology. Infrared Sensors. [online]
URL: <https://wiki.metropolia.fi/display/sensor/Infrared+sensors>
Accessed on October 17, 2016
- 16 Zainab Yunusa, Mohd. Nizar Hamidon, Ahsanul Kaiser. Gas Sensors: A Review. 30 April 2013.
URL:http://www.sensorsportal.com/HTML/DI-GEST/april_2014/Vol_168/P_1957.pdf
Accessed on November 15, 2016
- 17 [b] RKI instruments. Gas Detection for Life. Infrared Sensor. [online]
URL: http://www.rkiinstruments.com/pages/faq/Catalytic_Infrared_Sensors.htm
Accessed on 14 January 2016
- 18 What is Microcontroller? [online]
URL: <https://www.futureelectronics.com/en/Microcontrollers/microcontrollers.aspx>
Accessed on November 15, 2015

- 19 Arduino Uno. Product Overview. Technical Specifications. [online]
URL: <http://digital.csic.es/bitstream/10261/127788/7/D-c-%20Arduino%20uno.pdf>
Accessed on November 16, 2016
- 20 Analog Devices. Low Voltage Temperature Sensors. TMP35/TMP36/TMP37 [online]
URL: http://dlnmh9ip6v2uc.cloudfront.net/datasheets/Sensors/Temp/TMP35_36_37.pdf
Accessed on November 17, 2016
- 21 Analog Devices TMP36 Temperature Sensor. [online]
URL: <https://www.abelectronics.co.uk/p/62/Analog-Devices-TMP36-Temperature-Sensor>
Accessed on November 17, 2016
- 22 TMP36-Analog Temperature Sensor- TMP36. [online]
URL: <https://www.adafruit.com/product/165>
Accessed on November 17, 2016
- 23 Aosong Electronics Co., Ltd. Digital-output relative humidity & temperature sensor/module. DHT22 datasheet. [online]
URL: <https://www.sparkfun.com/datasheets/Sensors/Temperature/DHT22.pdf>
Accessed January 15, 2017
- 24 Electro Schematics. Arduino DHT22 (AM2302) Tutorial + Library. [online]
URL: <http://www.electroschematics.com/11291/arduino-dht22-am2302-tutorial-library/>
Accessed January 15, 2017
- 25 Joseph Dattilo. Virtuabotix DHT22 Pinout and coding guide. January 16, 2014 [online]
URL: <https://www.virtuabotix.com/virtuabotix-dht22-pinout-coding-guide/>
Accessed January 15, 2017
- 26 Jayant. IR Sensor Module Circuit. [online]
URL: <http://circuitdigest.com/electronic-circuits/ir-sensor-circuit-diagram>
Accessed December 26, 2016
- 27 Online Trading. IR infrared Obstacle Detection Sensor Module 2-30cm FC-51. [online]
URL: <http://qqtrading.com.my/ir-infrared-obstacle-detaction-sensor-module-fc-5>
Accessed December 26, 2016

- 28 MQ-135 sensor datasheet- Olimex. [online]
URL: <https://www.olimex.com/Products/Components/Sensors/SNS-MQ135/resources/SNS-MQ135.pdf>
Accessed January 12, 2017
- 29 MQ-135 image. [online]
URL: <http://warefab.com/product/49/>
Accessed on Jan 18, 2017
- 30 Logitech. HD WEBCAM. Portable HD calls. Specifications. [online]
YRL: <http://www.logitech.com/en-roeu/product/hd-webcam-c525>
Accessed on Jan 8, 2017
- 31 Logitech HD C525 web camera image. [online]
URL: http://support.logicool.co.jp/ja_jp/product/hd-webcam-c525
Accessed on Jan 2, 2017
- 32 Arduino IDE Software. [online]
URL: <https://www.arduino.cc/en/Guide/Environment#toc12>
Accessed December 26, 2016
- 33 National Instruments. LabVIEW System Design Software. [online]
URL: <http://www.ni.com/newsletter/51141/en/>
Accessed on Jan 8, 2017
- 34 National Instruments. Vision Acquisition Software. [online]
URL: <http://sine.ni.com/nips/cds/view/p/lang/finid/12892>
Accessed on Jan 8, 2017

Main Code

```

#define DHTTYPE DHT22 //The DHT11 and DHT22 has same code for operation, but they take different values different from
//library, hence the DHT22 type of sensor is defined

DHT dht(DHTPIN, DHTTYPE);

int sensorPin = A1; //The output of the MQ-135 sensor is connected to A1 pin of arduino.
//the output value obtained is integer

int sensorValue = 0; //the output value of MQ-135 sensor is obtained as integer value

int RawValue = 0; //raw voltage obtained from TMP36. which is in millivolts. obtained as integer value

const int analogIn = A0; //The output of TMP36 sensor is connected to analog input A0 of arduino.
//analog value(mV) received is integer

double Voltage = 0; //the output voltage(V) in the in decimal form

double tempC = 0; //Temperature value is dispalyed in decimal form as well

String in, out; //total representing entry of obstacle.it is set to be 0 at beginning

int total=0; //total representing entry of obstacle.it is set to be 0 at beginning

int total1=0; //total1 representing exit of obstacle.it is set to be 0 at beginning

int LED = 13; // Use the onboard Uno LED

int isObstaclePin = 4; // the output pin of one IR sensor module is connected to digital pin 4 of arduino.
//This is our input pin for indicating if there is bird inside or not.this sensor may or may not be used according
//to the desire of the project

int isObstacle = HIGH; // HIGH MEANS NO OBSTACLE,is the IR sensor module do not sense anything, the digital output is 1.
//if it senses something, the output becomes LOW

void setup() //initialiazing the input pins and variables
{
  pinMode(8, INPUT); //for IR sensor module
  pinMode(7, INPUT); //for IR sensor module
  pinMode(LED, OUIPUT); //for LED
  pinMode(isObstaclePin, INPUT); //initialiazing the pin 4
  Serial.begin(9600); //initialiazing the serial monitor
  dht.begin(); //initialiazing the DHT sensor library
}

void loop() //running the loop continuously until the microcontroller is stopped or reset
{
  sensorValue = analogRead(sensorPin); //reads the analog voltage value (mV) from MQ-135 sensor
  float h = dht.readHumidity(); // Reads humidity value from DHT22
  float t = dht.readTemperature(); // Reads temperature as Celsius from DHT22 (the default)
  float tf = dht.readTemperature(true); // Check if any reads failed and exit early (to try again)

  Serial.print("\n"); //prints new line
  Serial.print("°C = "); //prints 'C' after temperature value
  Serial.print(tempC,1); //prints temperatuere value
  Serial.print(" "); //leaves two character space between previous and next value
  Serial.print(" H "); //prints Humidity value
  Serial.print(h);
  Serial.print(" ");
  Serial.print(" I "); //prints temperatuere value
  Serial.print(t);
  Serial.print(" ");
  Serial.print(" F "); //prints temperatuere value in Fahrenheit
  Serial.print(tf);
  Serial.print(" ");
  Serial.print(total); //prints total entry integer value
  Serial.print(" ");
  Serial.print("En"); //prints En. meaning Entry after 'total' value
  Serial.print(" ");
  Serial.print(total1); //prints total exit integer value
  Serial.print(" ");
  Serial.print("Ex"); //prints Ex. meaning Exit after 'total1' value
  Serial.print(" ");
  Serial.print(sensorValue); //prints analog output value of MQ-135 sensor
  Serial.print(" ");

```

Block diagram for Arduino readings in LabVIEW

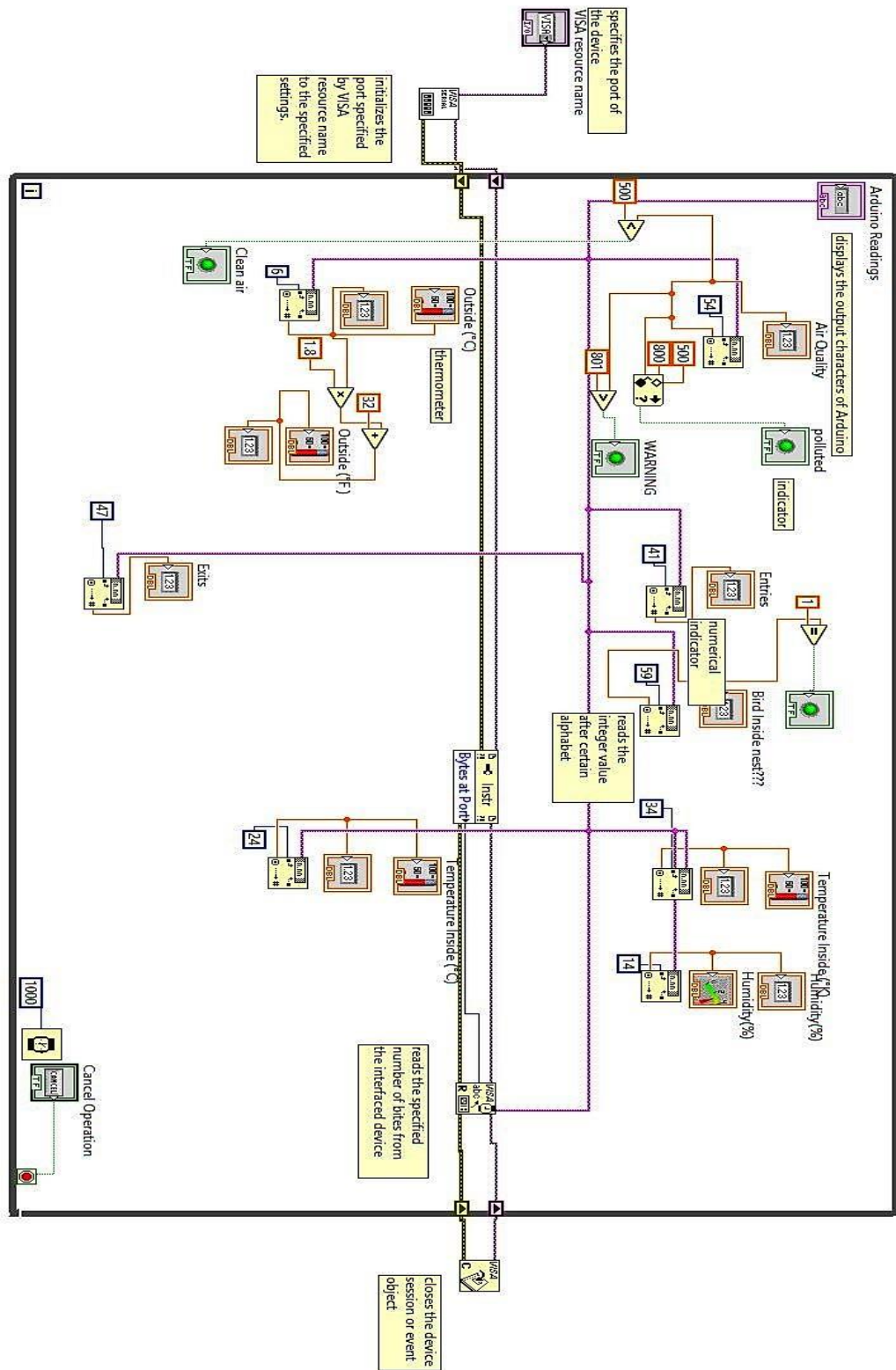

Block diagram for generating video in LabVIEW

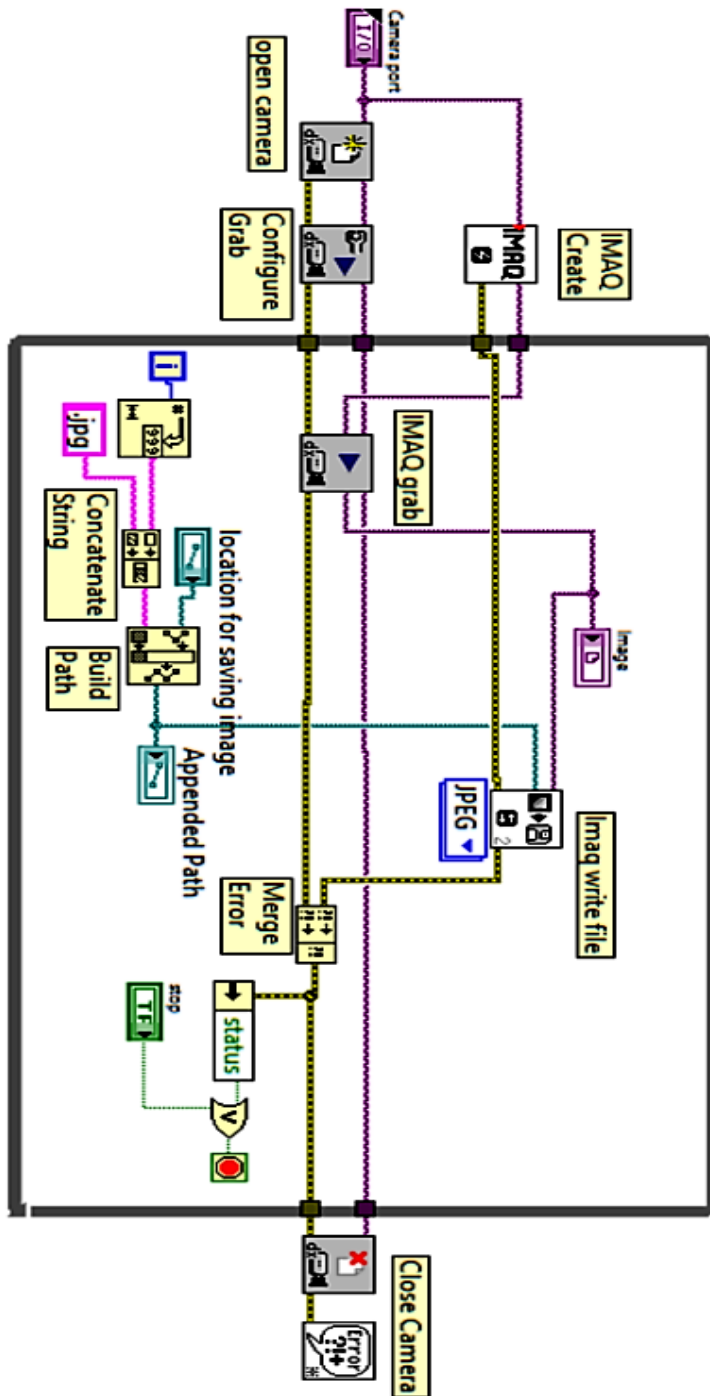

Test results with LabVIEW

The screenshot displays a LabVIEW front panel titled "labviewdht11sensorfina1.vi Front Panel". The interface includes a menu bar (File, Edit, View, Project, Operate, Tools, Window, Help) and a toolbar with standard application controls. The main display area is divided into several sections:

- Arduino Readings:** Shows VISA resource name as "COM6" and a status bar with "A°C = 31.1 H:37.00 T:23.00 F:73.40 2 En 5 Ex 427".
- Humidity:** A gauge and a linear scale. The gauge needle points to approximately 37%. The linear scale shows "Humidity(%) 37".
- Temperature:** Two linear scales. The first is labeled "Temperature inside (°C)" with a value of "23". The second is labeled "Temperature inside (°F)" with a value of "73.4".
- Outside Temperature:** Two linear scales. The first is labeled "Outside (°C)" with a value of "31.1". The second is labeled "Outside (°F)" with a value of "87.98".
- Air Quality:** A section with three indicator lights: "Clean air" (green, lit), "polluted" (dark green, unlit), and "WARNING" (dark green, unlit). The "Air Quality" value is "427".
- Bird inside nest???** A section with a single indicator light (green, lit) and a value of "1".
- Camera:** A "Camera port" dropdown menu set to "cam1" and a "STOP" button. Below it is a large "Image" window showing a live video feed of a bird's nest with a camera and various wires.
- File Management:** A "location for saving image" field containing "1600x896 32-bit RGB image 49,57,61 (48,148)". Below it is an "Appended Path" field containing "g:\Users\Bishal\Desktop\Fotos\543.jpg".

The bottom status bar shows "Main Application Instance" and a search bar.

Installation of the DHT22, IR sensor module, Webcam and MQ-135 inside nestbox



Installation of TMP36 and IR sensor module outside the nestbox

