

# **Thermal design of heat exchanger for a swimming pool**

Addisu Teka

Degree Thesis  
Industrial management  
2012

|   |  |
|---|--|
| DEGREE THESIS   |  |
| Arcada:Department of Technology   |  |
|   |  |
| Degree Programme:   | Industrial Management                                |
|   |  |
| Identification number:  | 8276   |
| Author:   | Teka Addisu  |
| Title:  | Thermal design of heat exchanger for a swimming pool |
| Supervisor (Arcada):  | Badal Karis Dubro                                    |
|   |  |
| Commissioned by:  | Arcada   |
|   |  |
| <p>Abstract:</p> <p>This paper tells about what is a heat exchanger made of in terms of thermal analysis and the important tools and factors which play vital role in designing them through the help of concepts learnt from heat transfer and fluid mechanics. The main objective of this paper is to design a reliable, economical heat exchanging system for different applications by selecting specific material which has a good thermal conductivity or convectivity property, designing profiles with desirable cross sectional areas to maximise the heating process. Almost all of contents and the analysis of the paper are based on the literatures available on the related subject and disciplines and a number of scientific rules together with heat transfer theories and facts have been incorporated abundantly. As the overall size of the heat exchanger is an important factor, the analysis has presented the steps and procedures needed to determine this variable and the cost aspects, which is also one of the most important tool has been discussed with the help of material selection and the economical perspective of popular materials. Ultimately the optimum overall heat transfer coefficient has been predetermined based on the requirements of amount of heat energy to be transferred by considering the other useful factors like Area of the heat exchanger, length of the heat exchanger tubes and the type of economic material. And it is found that the overall heat transfer coefficient can be maximised or minimised depending on the design and configuration of the whole system and can serve as a measure of the heat exchanging system.</p> |  |
| Keywords:   | LMTD,heat exchanger                                  |
| Number of pages:  | 43   |
| Language:   | English  |
| Date of acceptance:   | 26.04.2012   |

## **Acknowledgment**

I am heartily thankful to my supervisor, Badal Karis Dubro, who is the program leader of Industrial Management for his encouragement, guidance and support from the initial stage to the final level of this paper and for he enabled me to develop an understanding of the subject.

This paper would not have been possible without the guidance and the help of Mr Nigel Kimberley, who in one way or another contributed and extended his valuable assistance in the preparation and completion of this study.

Lastly, I offer my regards and blessings to all of those who supported me in any respect during the completion of the project.

Teka Addisu

# Table of Contents

|   |    |
|---|----|
| 1. Introduction.....                                | 1  |
| 1.1 Background .....                                | 1  |
| 1.2 Definitions.....                                | 1  |
| 1.3 Research aims and goals .....                   | 2  |
| 1.4 Literature review.....                          | 3  |
| 1.5 Limitations .....                               | 3  |
| 2. Theory.....                                      | 4  |
| 2.1 Modes of heat transfer .....                    | 4  |
| 2.1.1 Conduction heat transfer.....                 | 4  |
| 2.1.2 Conduction heat transfer rate .....           | 6  |
| 2.1.3 Convection heat transfer .....                | 7  |
| 3. Analysis of heat exchangers .....                | 9  |
| 3.1 Types of heat exchangers .....                  | 9  |
| 3.1.1 Plate heat exchanger .....                    | 9  |
| 3.1.2 Double pipe heat exchanger.....               | 11 |
| 3.1.3 Shell and tube heat exchangers .....          | 13 |
| 3.2 Overall heat transfer coefficients.....         | 14 |
| 4. Method.....                                      | 15 |
| 4.1 Heat exchanger design .....                     | 15 |
| 4.1.2 Log mean Temperature difference Approach..... | 16 |
| 4.2 Design Parameters .....                         | 20 |
| 4.3 Designing a swimming pool heat exchanger.....   | 21 |
| 5. Result and findings.....                         | 23 |

|   |    |
|---|----|
| 5.1 Finding the outlet temperature of the cold water..... | 23 |
| 5.2 Determining the sizes of the heat exchanger.....      | 24 |
| 5.3 Economical design considerations.....                 | 28 |
| 5.3.1 Cost.....   | 28 |
| 5.3.2 Material selection .....                            | 28 |
| 6. Discussion.....  | 31 |
| 7. Conclusion .....                                       | 32 |
| 8. References.....  | 33 |
| 9. Appendices .....                                       | 35 |
| Appendix 1 .....  | 35 |
| Appendix 2.....   | 37 |

## List of Symbols

| Symbol    | stands for (unit)                                 |
|-----------|---|
| A         | Area ( $m^2$ )                                    |
| c         | specific heat(J/K)                                |
| E         | Enthalpy (J)                                      |
| h         | convective heat transfer coefficient( $W/m^2.K$ ) |
| K         | thermal conductivity ( $W/m.K$ )                  |
| U         | overall heat transfer coefficient ( $W/m^2K$ )    |
| L         | length (m)  |
| d         | diameter (m)                                      |
| r         | radius(m)   |
| X         | thickness (m)                                     |
| q         | The heat-transfer rate (watt)                     |
| q''       | heat flux(watt/ $m^2$ )                           |
| v         | velocity (m/s)                                    |
| $\rho$    | Density ( $kg/m^3$ )                              |
| T         | Temperature (K)                                   |
| $\dot{m}$ | Mass flow rate (kg/s)                             |
| $\Delta$  | change in   |

# **1. Introduction**

## **1.1 Background**

The challenges of nature has been a driving force for the creation of several devices that made a significant difference in human's life so that people manage to live their life better and enjoy their daily activities properly. It is difficult to imagine life without access to be warmed in areas where the major seasons of the year are dominated by cold weather condition, and hence there needs to be heating devices and the systems to transport heat with the desirable temperature. And for people who are living in a turbulent weather conditions which is changing day by day, there should be a mechanism by which they can cope up with this situation. In the winter it might be too cold and in the summer it might be too hot and therefore the need for heat exchangers and air conditioners at home so that a desired room temperature can be adjusted by the help of the hot water circulating through the pipes of the building heating systems for the heat exchangers and cooling the hot environment by air conditioning so that they provide comfort during either hot or cold weather in a building and we can also keep the engine of our cars working properly through the help of the heat radiators which radiates the hot air to the surrounding ambient air avoiding the risk of internal engine from being very hot. Ventilation is also required in electronic to normalize the heated environment created by the internal circuit activities. In this thesis the author tries to present the procedures for designing a simple swimming pool heat exchanger with the recommended design parameter tips.

## **1.2 Definitions**

A heat exchanger is a device that allows the transfer of heat energy between two media for example water and air or other fluids. Heat exchangers are widely used in refrigeration air conditioning, and chemical plants. They can be employed in various uses, for instance, to effectively transmit heat from one fluid to the other. They have very important application in car industry in a way the optimal working temperature in the internal combustion engine is achieved through the use of the radiator which radiates the heat from the heated coolant coming from the engine to the surrounding air. The residential and office buildings in the cold winter seasons are

kept warmer by installing heat exchangers which facilitate to maintain comfortable ambient temperature from the hot water circulating and arriving at the heat exchangers.

In this thesis work the author tries to put the very important parameters when designing heat exchangers with different specifications as per the demand for the device. The specification would be the type of the heat exchanger, the material, the temperature range. The amount of heat transfer can be maximized by mounting fins (extended surfaces) on the heat exchangers or radiators. The typical importance of these elements is to increase the surface area of the circulating fluid resulting in the increase of amount of heat transfer

### **1.3 Research aims and goals**

The main objective of the thesis is to design a swimming pool heat exchanger system with reasonable heat transfer coefficient to achieve a desirable swimming pool temperature. Since there are many kinds of heat exchangers in our day to day lives for example, heaters in our home, cars, electrical equipments etc. are among the common heat exchangers and giving details of the working principle behind these devices and the processes of heat transfer would be of a great importance when designing a simple heat exchanger by considering and taking instances of loads and capacities of automotive, residential building and electrical appliances.

The other purposes of this paper are to deliver information on design, construction, and operation of heat exchangers with theoretical demonstration of how to apply theories of fluid mechanics and heat transfer and how to find solutions for practical problems posed by design, material selection, accommodating of heat exchangers. And to show how the properties of materials used as fluid greatly influence the heat transferring process and how the heat transfer rate is affected by different factors such as surface area, thermal property of materials and temperature differences between fluids when designing economical and affordable heat exchangers.



## **1.4 Literature review**

In this paper, the author use combined theories from heat transfer [2] and fluid mechanics [4] books which the author has been using in the program, and there will be details of formulations of definitions, a brief explanation of concepts and theories from different literatures and terminologies. Previous related studies have been made on this subject ranging from degree thesis to popular books [1] giving details of the economic variables when designing a heat exchangers. There are always important factors for a proper design of a device and this paper discusses the cost and amount of heat transfer required together with the size and pressure drop characteristics as a must-consider parameters. Studies and practical applications with brief calculations and theoretical measurements of different quantities to compare cost of heat exchangers when using different materials and the service they would deliver will be employed. And it has been noted that the heat transfer rate and cost are highly influenced by the selection of material.

## **1.5 Limitations**

The scope of this paper is up to comparing different features or specifications of heat exchangers and the discussion will take the form of thermal analysis where the author limit his discussion to heat exchangers by focusing on only conduction and convection heat transfer modes. And heat exchangers involving further radiation heat transferring mode can be referred from other books, Sparrow and Cess [3] and implementation of this paper are not included as they are beyond the scope of this paper.

## 2. Theory

### 2.1 Modes of heat transfer

When there is a temperature difference in a body, studies has shown that there is a heat energy transfer from the higher temperature region to the lower temperature region through different modes of heat transfer, namely conduction, convection or radiation heat transfer

#### 2.1.1 Conduction heat transfer

Conduction may be explained as the spontaneous transfer of energy from the more energetic solid particles to the less energetic solid particles of a substance due to direct contact between particles. a simple example of conduction can be understood when we cook our food at home.

Think of a frying pan set over an open camp stove. The fire's heat causes molecules in the pan to vibrate faster, making it hotter. These vibrating molecules collide with their neighboring molecules, making them also vibrate faster. This process continues until the entire pan has heated up due to the vibrating and colliding molecules. If you've ever touched the metal handle of a hot pan without a potholder, you have first-hand experience with heat conduction!

Some solids, such as metals, are good heat conductors, while others, such as wood, are poor conductors. Air and water are relatively poor conductors and thus are called **insulators**. Not surprisingly, many pots and pans have insulated handles. Think of a frying pan set over an open camp stove. The fire's heat causes molecules in the pan to vibrate faster, making it hotter. These vibrating molecules collide with their neighboring molecules, making them also vibrate faster. This process continues until the entire pan has heated up due to the vibrating and colliding molecules. If you've ever touched the metal handle of a hot pan without a potholder, you have first-hand experience with heat conduction!

Some solids, such as metals, are good heat conductors, while others, such as wood, are poor conductors. Air and water are relatively poor conductors and thus are called **insulators**. Not surprisingly, many pots and pans have insulated handles.

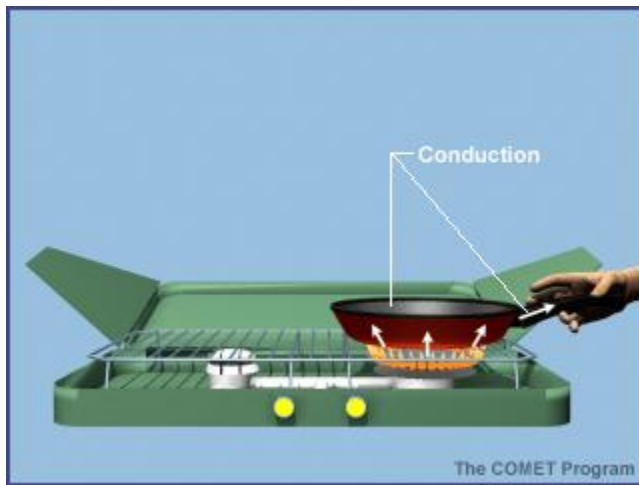

Figure2- 1:conduction heat transfer [5]

### 2.1.2 Conduction heat transfer rate

Conduction can occur only if there is a difference in temperature between two parts of the conducting medium, the following figures illustrates to visualize the process

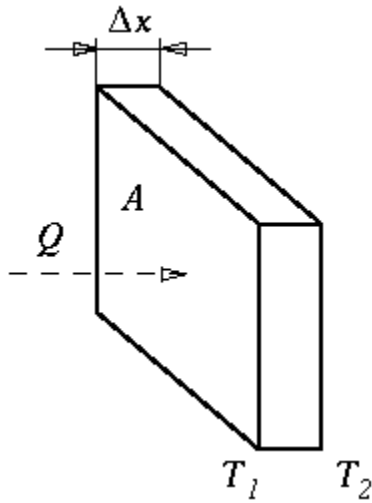

Figure 2-2: elemental volume for one dimensional heat conduction analysis [6].

The slab allows energy to transfer from the region of higher temperature to the region of lower temperature

The amount of heat transfer rate per unit area is proportional to the normal temperature gradient

(  $\frac{\Delta T}{\Delta X}$  ) [1, p2] where  $\Delta T$  is the temperature difference between the cold temperature,  $T_2$  and the hotter temperature,  $T_1$

$$\Delta T = T_1 - T_2$$

$$\frac{q}{A} \sim \left( \frac{\Delta T}{\Delta X} \right)$$

When the proportionality constant is inserted

$$q = \frac{-k A \Delta T}{\Delta X} \quad (2-1)$$

Conduction, equation explanation

q Is the heat-transfer rate, in watts?

A is cross-sectional area, in m<sup>2</sup>

K is the thermal conductivity of the material, W/(m.K)

$\Delta T/\Delta X$  is the temperature gradient

The minus sign shows heat transfer occurs in the direction of decreasing temperature.

Heat flux,  $q''$  can also be defined as the heat transfer rate per unit area and it can be written as

$$q'' = -k \frac{\Delta T}{\Delta X} \quad (2-2)$$

K, the thermal conductivity is a property of a material which indicates how well or bad a substance is for heat conduction. Generally, good conductors have high k values and good insulators have low k values. The list of k values for different materials is available in appendix 1

### 2.1.3 Convection heat transfer

When energy is transferred because of the random molecular motion or due to the macroscopic physical motion of a fluid we simply say it is a convection heat transfer. the random motion of molecules with the the presence of temperature gradient results in the transportation of energy from the hotter temperature to the colder temperature. And the overall heat energy transported is the cumulative of each molecule's delivery effect.

The velocity boundary layer (figure 2-3) illustrates how the motion of the fluid propagates from lower velocity ( $u=0$ ) to the finite velocity  $u_{\infty}$ .at the surface of the heated surface there is

conduction heat transfer and as the particles of the fluid carries away the heat to the neighboring molecules the convection heat transfer dominates.

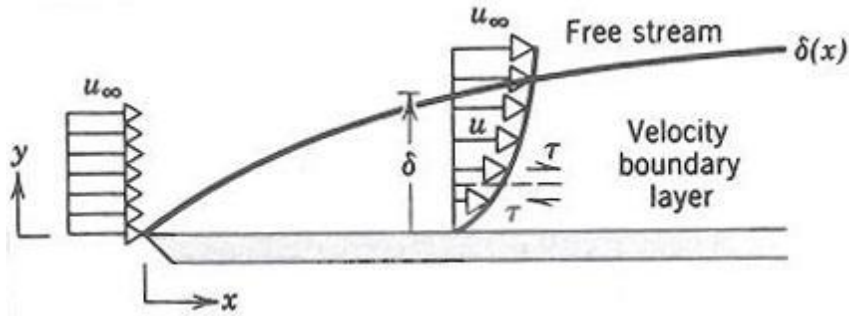

Figure 2-3: convection heat transfer from a heated surface [2]

To express the overall effect of convection, Newton's law of cooling is adapted

$$q = h A (T_s - T_\infty) \quad (2-3)$$

Where  $T_s$  is the surface temperature

$T_\infty$  is the fluid temperature and

The heat transfer rate is a function of the overall temperature difference between the surface and the fluid, the area  $A$ .  $h$ , stands for the convection heat transfer coefficient ( $W/m^2 \cdot ^\circ C$ ).

The convection heat transfer depends on the viscosity of the fluid, and the thermal properties of the fluid such as thermal conductivity, specific heat and density. This is because viscosity affects the velocity profile and correspondingly, the energy –transfer rate in the region near the surface heat.

When a heated plate is exposed to ambient room air without an external source of motion, movement of the air would be experienced as a result of the density gradients near the plate. We call them natural, or free convection as opposed to forced convection, which is experienced in the case of fan blowing air over a plate [1,p13].

### 3. Analysis of heat exchangers

A heat exchanger is a specialized device that assists in the transfer of heat from one fluid to the other. In some cases, a solid wall may separate the fluids and prevent them from mixing. In other designs, the fluids may be in direct contact with each other. In the most efficient heat exchangers, the surface area of the wall between the fluids is maximized while simultaneously minimizing the fluid flow resistance. Fins or corrugations are sometimes used with the wall in order to increase the surface area and to induce turbulence.

#### 3.1 Types of heat exchangers

Heat Exchangers have numerous different types and applications. The selection of the specific heat exchanger can be done by specifying the application the device will be used for. The design process can be discussed later in the thesis and mostly based on calculation of the required area to transfer heat from one fluid to another and the physical and chemical properties of the fluids so that designers can determine the actual mechanical design parameters.

The main focal point for this thesis concerns on the type of heat exchanger called the double pipe heat exchanger selected as it is more appropriate for buildings and other applications, and its design procedures and their related applications comes to discussion for the rest of the paper .The author recommends readers to refer other sources such as Holman [1] and Incropera[2] for the other types of heat exchangers focuses on this specific heat exchanger and its design procedures and their related applications for the the rest of the thesis.

Some of the types of heat exchangers are:

##### 3.1.1 Plate heat exchanger

The Overall Heat Transfer Coefficient (U) for Plate heat exchanger can be expressed [1] as

$$\frac{1}{U} = \frac{1}{h_1} + \frac{\Delta X_w}{k} + \frac{1}{h_2} \quad (3-1)$$

Where

$U$  = the overall heat transfer coefficient ( $W/m^2K$ )

$k$  = the thermal conductivity of the material ( $W/mK$ )

$h$  = the individual convection heat transfer coefficient for each fluid ( $W/m^2K$ )

$\Delta X_w$  = the wall thickness (m)

The thermal conductivity -  $k$  - for some typical materials:

Polypropylene PP - 0.12 W/mK

Stainless steel - 21 W/mK

Aluminum - 221 W/mK

The convection heat transfer coefficient -  $h$  - depends on

- the type of fluid - gas or liquid
- the flow properties such as velocity
- other flow and temperature dependent properties

### 3.1.1.1 Heat Transfer in a plate Heat Exchanger

Example: A single plate exchanger with media A transfers heat to media B. The wall thickness is 0.1 mm and the material is polypropylene PP, aluminum or stainless steel.

Media A and B are air with a convection heat transfer coefficient of  $h_{air} = 50 W/m^2K$ .

The overall heat transfer coefficient  $U$  per unit area can be expressed as:

$$U = \frac{1}{\left(\frac{1}{h_A} + \frac{\Delta X_w}{k} + \frac{1}{h_B}\right)}$$

Using the values from above the overall heat transfer coefficient can be calculated to:

- Polypropylene PP :  $U = 24.5 W/m^2K$



- Steel :  $U = 25.0 \text{ W/m}^2\text{K}$
- Aluminum:  $U = 25.0 \text{ W/m}^2\text{K}$



Figure 3-1: a plate heat exchanger[9]

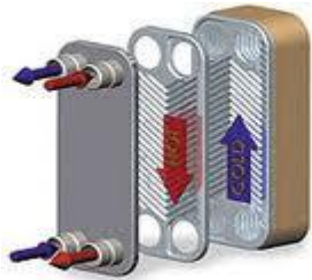

Figure 3-2: a flow pattern in a plate heat exchanger[10]

### 3.1.2 Double pipe heat exchanger

Overall heat transfer coefficient ( $U_{OA}$ ) for double pipe heat exchanger can be formulated as follows

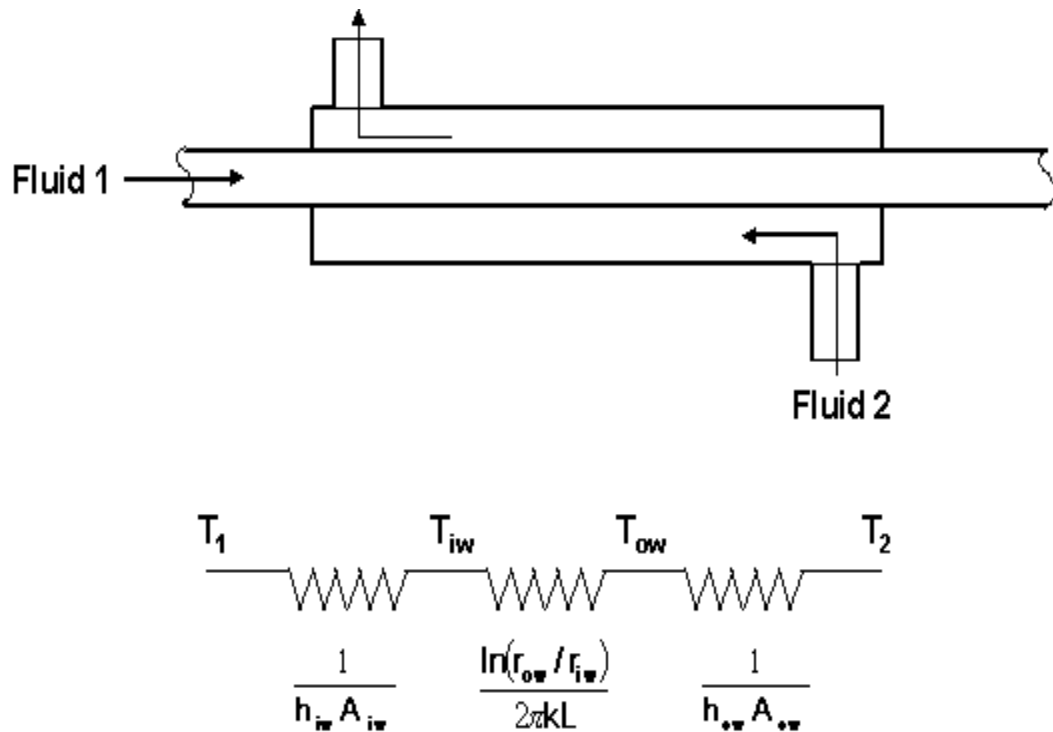

Figure3-3: schematic diagram of parallel flow and thermal resistance network of the double pipe heat exchanger[9]

The double pipe heat exchanger shown in this figure provides a practical example of how to apply the above figure. In the figure, the subscript "ow" stands for "outside wall" and "iw" stands for "inside wall". Heat is exchanged between the inner fluid and the outer fluid. In terms of the figure the overall heat transfer coefficient is

$$U_{OA} = \frac{1}{\frac{1}{h_{iw} A_{iw}} + \frac{\ln(r_{ow}/r_{iw})}{2\pi kl} + \frac{1}{h_{ow} A_{ow}}} \quad (3-2)$$

The hot fluid, say Fluid 1 passes through the entire length and on its way transfers heat convectively, to the inside walls of the tube, then heat is transferred to the outside walls of the

tube through **conduction**. And as the cold fluid comes (say fluid 2) it absorbs the heat from the outside wall throughout its length to its outlet.

Basically what is happening is a combined process of

**convection**→ **conduction**→**convection**

Temperatures are changing from point to point for each fluid. Since the heat transfer rate is dependent on temperature; it varies throughout the length of the heat exchanger. Since the heat transfer process is the result of the above combined processes there should be a way to formulate the overall heat transfer coefficient,

### 3.1.3 Shell and tube heat exchangers

These are types of heat exchangers with the outer area surrounding the tubes called shell side and the inside of the tubes are called tube side baffles are usually installed to increase the convective coefficient of the shell side fluid by inducing turbulence.



Figure 3- 4:shell and tube heat exchanger[13]

### 3.2 Overall heat transfer coefficients

Table 3-1 approximate values of overall heat-transfer coefficients.

| Physical situation  | U(W/m <sup>2</sup> .°C) |
|---|-------------------------|
| Plate- glass window   | 6.2                     |
| Water- to -water heat exchanger                             | 850-1700                |
| Finned-tube heat exchanger, water in tubes air across tubes | 25-55                   |
| Water- to- oil heat exchanger                               | 110-350                 |
| Finned -tube heat exchanger, steam in tubes, air over tubes | 28-280                  |
| Gas-to –gas heat exchanger                                  | 10-40                   |

## 4. Method

**4.1 Heat exchanger design:** when designing the heat exchanger the following quantities have to be known

1. The desired hot or cold fluid outlet temperatures
2. The inlet temperatures
3. The flow rates of the fluid.

The ultimate goal to solve the design problem by specifying:

The heat exchanger type which in turn determines the size or the surface area needed to achieve desired outlet temperatures.

### 4.1.1 Heat exchanger analysis:

The design and performance of a heat exchanger dependent on the amount of total heat transfer rate and this in turn results in quantities such as the inlet and outlet fluid temperatures, the overall heat transfer coefficient and the total heat transfer area.

If  $q$  is the total heat transfer between the hot and cold fluid, the steady flow energy equation gives us

$$q = \dot{m}_h(E_{h,i} - E_{h,o}) \quad (4-1)$$

$$q = \dot{m}_c(E_{c,o} - E_{c,i}) \quad (4-2)$$

Where,  $E$  stands for the fluid enthalpy and the subscripts  $h$  and  $c$  stand for the hot and cold fluid respectively and subscripts  $i$  and  $o$  represent the inlet and outlet conditions. And

$\dot{m}$  Is the mass flow rate of the fluid?

$q$  can also be expressed as a function of specific heat and temperatures where the fluid doesn't undergo a phase change for any flow arrangement.

$$q = \dot{m}_h c_{p,h} (T_{h,i} - T_{h,o}) \quad (4-3)$$

$$q = \dot{m}_c c_{p,c} (T_{c,o} - T_{c,i}) \quad (4-4)$$

Where  $c_p$  is the specific heat of the fluid

As in equation (2-3) for a heat exchanger it is possible to parallel the quantities of the convective heat transfer with that of a heat exchanger with  $\Delta T = T_h - T_c$ , the temperature difference between the hot and cold fluids,

Where  $T_h$  - is the temperature of the hot fluid

$T_c$  - is the temperature of the cold fluid

$$q = UA\Delta T \quad (4-5)$$

#### 4.1.2 Log mean Temperature difference Approach

There are two types of modes of heat transport in a heat exchanger

Direction of fluid flow within the exchanger determines the modes of operation and the effectiveness of heat exchanger.

**Parallel flow (co-current flow)** : in this type of heat exchanger the fluids flow in the same direction. The temperature difference at the inlet sections is large and it decays as it flows through the length, approaching zero asymptotically. The outlet temperature of the cold fluid never exceeds that of the hot fluid.

**Counter flow (counter current flow)**: the mode of flow of the working fluids is opposite direction. The change in the temperature difference is not as large as it is for the inlet region of the parallel flow exchanger. The outlet temperature of the cold fluid may exceed the outlet temperature of the hot fluid.

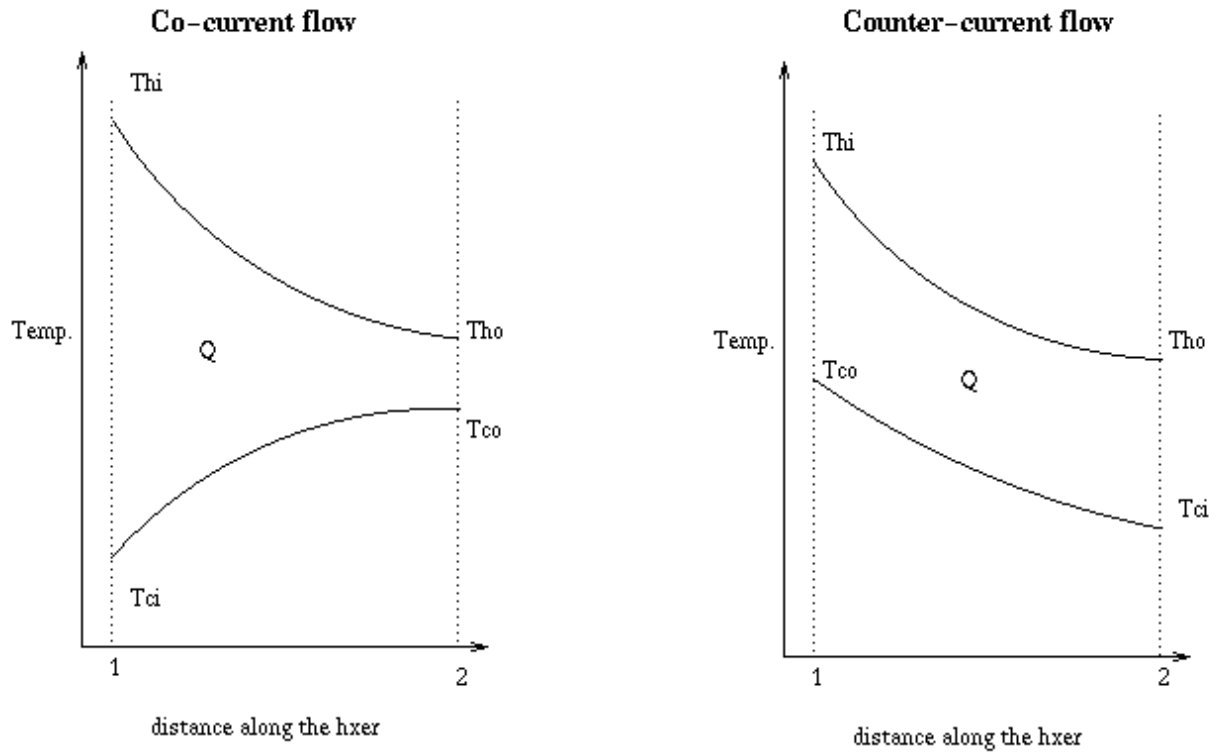

Tci = Cold fluid inlet temperature  
 Tco = Cold fluid outlet temperature  
 Thi = Hot fluid inlet temperature  
 Tho = Hot fluid outlet temperature

Figure 4-1 parallel flow (l) and counter flow (r) [14]

For parallel flow (co-current flow) arrangement the mean temperature can be analyzed as

$$dq = -\dot{m}_h c_{p,h} dT_h = -C_h dT_h \quad (4-6)$$

And

$$dq = \dot{m}_c c_{p,c} dT_c = C_c dT_c \quad (4-7)$$

In other way

$$dq = U \Delta T dA \quad (4-8)$$

and since  $\Delta T = T_h - T_c$ ,  $d(\Delta T) = dT_h - dT_c$

$$d(\Delta T) = -dq \left( \frac{1}{C_h} + \frac{1}{C_c} \right)$$

Substituting for  $dq$  from equation (4-7)

$$d(\Delta T) = -U \left( \frac{1}{C_h} + \frac{1}{C_c} \right) dA \Delta T$$

$$\frac{d(\Delta T)}{\Delta T} = -U \left( \frac{1}{C_h} + \frac{1}{C_c} \right) dA$$

Integrating

$$\int_1^2 \frac{d(\Delta T)}{\Delta T} = -U \left( \frac{1}{C_h} + \frac{1}{C_c} \right) \int_1^2 dA$$

$$\ln \left( \frac{\Delta T_2}{\Delta T_1} \right) = -UA \left( \frac{1}{C_h} + \frac{1}{C_c} \right)$$

Substituting  $C_h$  and  $C_c$  from equations (4-3) and (4-4) and rearranging

$$\ln \left( \frac{\Delta T_2}{\Delta T_1} \right) = -\frac{UA}{q} [(T_{h,i} - T_{c,i}) - (T_{h,o} - T_{c,o})]$$

For parallel flow heat exchanger of the figure 4-1  $\Delta T_1 = T_{h,i} - T_{c,i}$  and

$$\Delta T_2 = T_{h,o} - T_{c,o}$$

$$\text{Then } q = UA \frac{\Delta T_2 - \Delta T_1}{\ln \left( \frac{\Delta T_2}{\Delta T_1} \right)}$$

$$q = UA \Delta T_{lm} \quad (4-9)$$

$\Delta T_{lm}$  Is the appropriate average temperature difference and is called as a **log mean temperature difference**, stated verbally it is the temperature difference at one end of the heat exchanger less



the temperature difference at the other end of the the exchanger divided by the natural logarithm of the ratio of these two temperature differences.

In this thesis the log mean temperature difference approach would be applied to analyze the design of a heat exchanger for the purpose a swimming pool given that the types of fluids, the inlet and desired outlet temperatures are known. Determining the size of the heat exchanger for specific size (dimensions) of a room (it might be office, living room or swimming pool and etc.)

\*if a specific type of fluid running through the tube and shells of a heat exchanger with

- inlet, outlet conditions
- purpose of the heat exchanger(eg for a certain size of room)
- mass flow rate
- overall heat transfer coefficient
- diameters of tubes

It is possible to design a heat exchanger with certain length and certain number of tubes so that it will be decided if it fits the space available and if it achieves the desired amount of heat transfer.

## 4.2 Design Parameters

1. Is there a **phase change** occurring? this can be answered by knowing the boiling temperatures of the fluids involved, in this case .no there is no a phase change since the boiling temperature of water is  $100^{\circ}\text{C}$ .

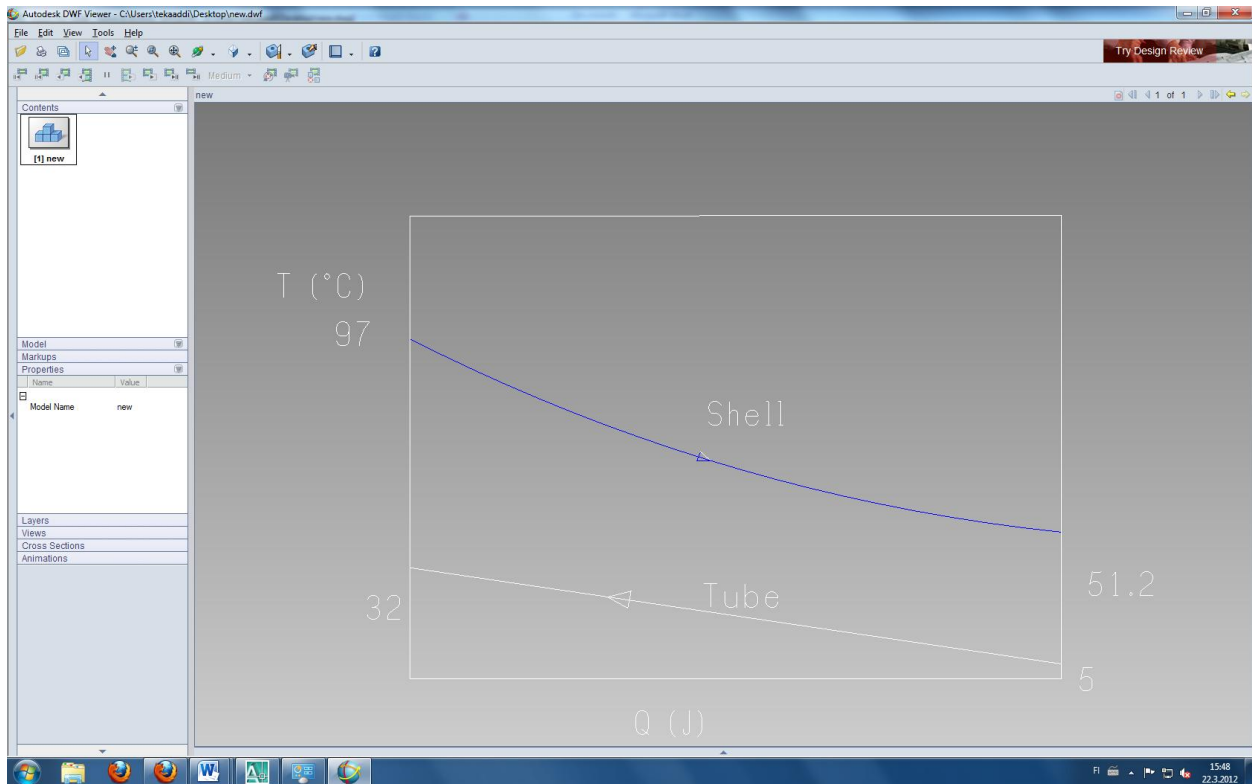

Fig 4-1 the T-Q diagram of the fluids in the heat exchanger

2. **The number of Zones** involved in the system (heat exchanger): spots of the phase change are represented as zones where the overall heat transfer coefficient varies. For this analysis the temperature – heat (T-Q) diagrams are used to illustrate these phenomena. Fluid 1 enters the shell at  $97^{\circ}\text{C}$  as a very hot water. It releases heat to the tube side fluid (fluid 2)

The fluid 2 enters as a liquid or gas and does not change phase throughout the exchanger.

Finally, both fluids have exchanged heat and Fluid 1 is simply liberating heat to fluid 2 as it becomes a sub cooled liquid and exits the shell at  $T_{ho}$  which is to be determined by calculation.

3. **Flow rates and operating pressure:** this is vital information for establishing the mass and energy balance through the heat exchanger.

4. The **physical properties of the fluids.**

Physical properties for each zone must be taken separately to ensure accuracy. But in some cases it is acceptable to use an average value. Especially this is acceptable for a situation there is no phase change or undergoing no significant temperature change. The physical properties which should be collected are heat capacity, thermal conductivity, density,

5. Allowable **pressure drops and velocities** in the heat exchanger: the velocity is directly proportional to the heat transfer coefficient which is a motivation to keep it high, while erosion and material limits are motivation to keep the velocity low. Typical liquid velocities are 0.3-3m/s, typical gas velocities are 15-30 m/s and typical pressure drops are 30-60 kPa (5-8 psi) on the tube side and 20-30 kPa (3-5 psi) on the shell side [12].

6. The **Heat quantity** of the system: this can be solved by a simple energy balance for one of the fluids involved.

7. **Estimated area of the Heat exchanger:** Once the heat transfer coefficient is specified (from books) it is easy to use the equation  $q = UA \Delta T_{lm}$ . Remember to use the above equation to get an area for each zone, and then add them together.

### 4.3 Designing a swimming pool heat exchanger

For a shell and tube heat exchanger to be placed on the floor attached to the wall of average sized swimming pool which is connected to the central heating system by pipes to maintain a reasonable temperature of the pool water approximating from 25 °c to 35°c.

Water can be transported to use as a heating fluid entering at 97°c on the shell side of the exchanger so that it drops some amount of heat to the neighboring environment while its

Mass flow rate is 1.65kg/s and the other fluid (water) is being heated at the same time on the tube side from 5°c to 32°c while its mass flow rate is 2.8kg/s. The heat exchanger is to be designed from 316 stainless steel. It is to be made so that it takes an ample amount of heat coming from an outdoor boiler entering the top end (on the shell side) of the swimming pool heat exchanger. This

hot water is then diffused over the surface of some pencil sized separate stainless steel tubes. These tubes are separated inside the swimming pool heat exchanger so when the colder swimming pool water enters the heat exchanger from the larger side ports the pools water enter the tubes and takes the heat from the hot water and then flows to the other end of the tubes. This process assumes the most effective way to heat transfer in swimming pools.



Figure 4-2 disassembled shell and tube swimming pool heat exchanger [13]



Figure 4-3 assembled shell and tube heat exchanger and exploded view of the tube sides [13]

## 5. Result and findings

### 5.1 Finding the outlet temperature of the cold water

The amount of heat lost by the hot fluid is the same as the amount gained by the cold fluid. From eq(4-3) and (4-4)

$$\mathbf{q} = \dot{m}_h c_{p,h}(T_{h,i} - T_{h,o}) = \dot{m}_c c_{p,c}(T_{c,o} - T_{c,i})$$

$c_{p,h} = c_{p,c} = 4186 \frac{J}{kg.k}$  (from Appendix 2) and since the fluids are the same and they are water

$$\dot{m}_h = 1.65 \text{kg/s,}$$

$$\dot{m}_c = 2.8 \text{kg/s}$$

$$T_{c,i} = 5, T_{c,o} = 32, T_{h,i} = 97, T_{h,o} = ?$$

$$T_{h,i} - T_{h,o} = \frac{\dot{m}_c c_{p,c}(T_{c,o} - T_{c,i})}{\dot{m}_h c_{p,h}}$$

$$T_{h,i} - T_{h,o} = \frac{(2.8)(32-5)}{1.65} = 45.8$$

$$T_{h,o} = 97 - 45.8 = 51.2$$

The outlet temperature is found to be higher than the outlet temperature of the cold water.

## 5.2 Determining the sizes of the heat exchanger

Calculating the overall heat transfer coefficient is a tedious task and it can be taken from table as it can be for simple conduction and convection coefficients.

$$U=1419\text{W/m}^2\cdot^{\circ}\text{C}$$

$$\mathbf{q} = \dot{m}_h c_{p,h} (T_{h,i} - T_{h,o})$$

$$= 1.65(4182)(45.8)$$

$$= 316 \text{ kW}$$

The amount of heat transferred can also be expressed by eq (4-8)

$$\mathbf{q} = UA \Delta T_{lm}$$

Design for counter flow arrangement

$$\Delta T_{lm} = \text{LMTD} = \frac{\Delta T_2 - \Delta T_1}{\ln\left(\frac{\Delta T_2}{\Delta T_1}\right)}$$

$$\Delta T_2 = T_{h,i} - T_{c,o} = 97 - 32 = 65$$

$$\Delta T_1 = T_{h,o} - T_{c,i} = 51.2 - 5 = 46.2$$

$$\Delta T_{lm} = \frac{65 - 46.2}{\ln\left(\frac{65}{46.2}\right)}$$

$$= 55.1^{\circ}\text{C}$$

The total surface Area,

$$A = \frac{q}{U\Delta T_{lm}} = \frac{3.16}{1419(55.1)} * 10^5 = 4.04 \text{ m}^2$$

the cold water (fluid) is to be pumped with a certain velocity of **0.3m/s** through the tubes,

$$\dot{m}_c = \rho A_f v, \quad \rho = 1000 \text{ kg/m}^3$$

$A_f$  the total flow area,

$\rho$  – Density of the fluid,

$V$ -velocity of the fluid

$$A_f = \frac{\dot{m}_c}{\rho V} = \frac{2.8}{1000(0.3)} = 0.0093 \text{ m}^2$$

The total no of tubes of the shell and tube heat exchanger( $n$ ) multiplied by the cross sectional area of the single tube whose diameter is supposed to be 2.0cm, is equivalent to the above area

$$n \frac{\pi d^2}{4} = 0.0093 \text{ m}^2$$

$$n = \frac{4(0.0093)}{\pi(0.02)^2} = 29.6$$

number of tubes = 30 tubes

The other relationship exists as each number of tubes consists of the cross section and this cross section extend throughout the length,

or mathematically

$$n\pi d.L = A$$

$$L = \frac{A}{n\pi d}$$

$$L = \frac{4.04}{\pi(0.02)(30)}$$

$$L = 2.14\text{m}$$

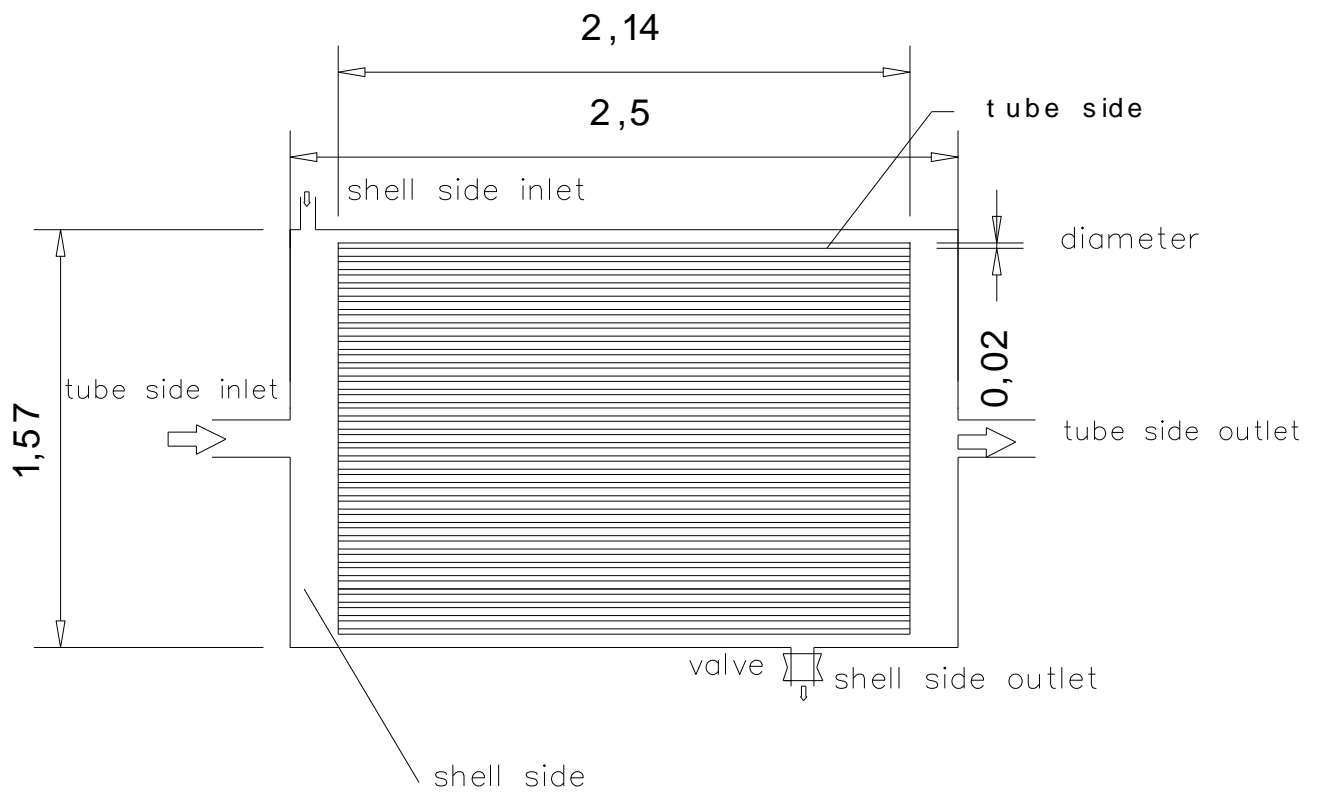

Figure 5-1 layout design for the swimming pool heat exchanger.

It is possible to design a shell and tube heat exchanger of the determined sizes so that the device doesn't take large space but warms the swimming pool effectively.



Table 5-1. calculated results of the heat exchanger.

|                                      |                      |
|--------------------------------------|----------------------|
| Log mean temperature                 | 55.1°C               |
| Total surface area of heat exchanger | 4.04m <sup>2</sup>   |
| Flow area                            | 0.0093m <sup>2</sup> |
| Number of tubes                      | 30                   |
| Length of tube                       | 2.14m                |
| Amount of heat transferred           | 316 kW               |

## **5.3 Economical design considerations**

Different manufacturers have produced a variety of heat exchangers so far and the products are available and selection is made based on the cost and technical specification quoted by the manufacturers. costs are relatively higher for the existing heat exchangers currently on the shelf of different manufacturers. When a heat exchanger is designed ,there are crucial factors which must be always considered and some of these are:

### **5.3.1 Cost**

Economical operation of the heat exchanger is achieved through careful considerations of the facts where is it going to be used or its application, if the heat energy transfer is to be maximized, the fluid can be pumped to the heat exchanger at a higher velocity resulting in a bigger mass flow rate and higher heat transfer coefficient. On the other hand pumping at higher velocity is a costly operation and it encourages larger pressure drop. The other options are increasing the physical size or the surface area through which the fluids exchange the heat energy when it is affordable and accommodated. The size of the heat exchanger has direct relationship with its cost because as the size is getting bigger the cost of construction rises. The selection of cheaper material which might make a big difference in terms of cost and operations from those existing in the market is considered by proposing a special material with good conductivity is effective and smart way of manufacturing heat exchangers.

### **5.3.2 Material selection**

Comparisons has made for the selection of material for heat exchangers in terms of the following properties

316 stainless steel

Wall mounted set up

- heat exchanger tube wall
- fouling resistance.

- The inside film resistance.
- The outside film resistances

Based on the properties above metals show a very good quality over plastic materials. but in recent decades different special plastics have been discovered by blending plastic with different properties to manufacture a polymer plastic with good thermal conductivity and this breakthrough supports the initial aim of this paper by reducing the cost of heat exchanger design.

When selecting a heat exchanger material, some points should be taken into considerations like the type of fluids (media), application, the temperature. different materials can be used for different types of heat exchanger.

Shell and tube – To be able to transfer heat well, the tube material should have good thermal conductivity

Shell side - carbon steel

tube side-316 stainless steel

The material selection is based on the cost and the durability (life expectancy).the economy of the material must balance with the service the heat exchanger has to deliver and its maintenance cost.

Corrosion is an everyday fact in the finished product industry; mild steel exchangers should be avoided, except for short-run processes. Instead, in most systems where corrosiveness of the atmosphere and solutions is low, type 316 stainless steel provides additional protection at a modest price.

To be able to transfer heat well, the tube material should have good thermal conductivity. Because heat is transferred from a hot to a cold side through the tubes, there is a temperature difference through the width of the tubes. Because of the tendency of the tube material to thermally expand differently at various temperatures, thermal stresses occur during operation. This is in addition to any stress from high pressures from the fluids themselves. The tube material also should be compatible with both the shell and tube side fluids for long periods under the operating conditions (temperatures, pressures, pH, etc.) to minimize deterioration such as

corrosion. All of these requirements call for careful selection of strong, thermally-conductive, corrosion-resistant, high quality tube materials, typically metals, including copper alloy, stainless steel, carbon steel, non-ferrous copper alloy, Inconel, nickel, ha and titanium. Poor choice of tube material could result in a leak through a tube between the shell and tube sides causing fluid cross-contamination and possibly loss of pressure.

## **6. Discussion**

In this thesis, as it was indicated earlier in the introduction section the author has come up with the view of the general concepts and procedures behind the design of a heat exchanger and has demonstrated the application of most important parameters in designing a shell and tube heat exchanger for a swimming pool.

The inlet and outlet temperatures through the shell and tube have been considered to calculate the amount of heat transfer from the incoming hot water to the swimming pool water which is waiting to be heated. These figures can also be changed to get higher or lower pool temperature and hence the size of the heat exchanger changes as well.

In determining the size of the heat exchanger such as: the total surface area of the heat exchanger, the total flow area, the number of tubes through which the fluid is flowing have demanded the use of the overall heat transfer coefficient, which in turn has demanded a long and tedious formulation, which is the reason why the author has taken this figure from other literature (tables).

In the final result, even though the length of the heat exchanger is a little bit bigger, the cost of the construction can be compensated through the thin-thread like tubes which have small cross sections throughout the length of the heat exchanger and the author also suggests the heat exchanger should be attached to the wall of the swimming pool horizontally and hence the wall length must be large enough to accommodate the heat exchanger.

## 7. Conclusion

The main objective of the thesis was to design an economically affordable heat exchanging system with higher heat transfer rate for an average sized swimming pool. The size of the heat exchanger plays the greatest role in deciding whether it is economical or not. It is obvious that the amount of heat transfer becomes higher when the heat exchanger size is of bigger dimensions but this would end up in consuming larger construction material resulting in uneconomical design.

The other and best option for achieving economical design is to minimize the overall size of the heat exchanger and to compensate the amount of the heat transfer by careful selection of the physical situation of heat exchangers so that it is possible to arrive at significant overall heat transfer coefficient. The water to water heat exchanger has been used and the overall heat transfer coefficient was taken from other literatures and found to be  $1400 \text{ W/m}^2 \cdot ^\circ\text{C}$ , which is remarkably high. Other factors such as the inlet temperatures are the normally used temperatures so that they could satisfy the real inlet conditions and obey the thermodynamic situations. The log mean temperature, which is the average temperature of the heat exchanger, has also been instrumental to determine the amount of heat transferred through the whole process. The overall heat transfer area has been important to determine how many tubes are ample to meet the desired conditions and also how long the tube would be.

By combining all the methods and procedures, the author has come to a conclusion through designing a compact sized or a heat exchanger with a small area. The notion of reducing the area by itself minimizes the consumption of the material for physical construction but selecting a relatively cheaper material which has a good heat transfer rate also makes the overall manufacturing cost lower. And it is noted that even though the heat transfer area is smaller, this could be overcome by making use of pre-determined higher overall heat transfer coefficient.

## 8. References

1. J.P Holman, heat transfer 10<sup>th</sup> edition McGraw-Hill, 2010
2. Incropera, Dewitt, Bergman, Lavine, Fundamentals of heat and mass transfer ,6<sup>th</sup> edition, John Wiley & Sons (2006)
3. Arcada thesis Guide available at <[http://studieguide.arcada.fi/en/webfm\\_send/584](http://studieguide.arcada.fi/en/webfm_send/584)> [Accessed 21 March 2011]
4. H. Yamaguchi, Engineering Fluid Mechanics, Doshisha University, Kyo-Tanabeshi, Kyoto, Japan 2008 Springer
5. University corporation for atmospheric research, Atmospheric Processes — Conduction available at <[http://www.ucar.edu/learn/1\\_1\\_2\\_6t.htm](http://www.ucar.edu/learn/1_1_2_6t.htm)> [Accessed 28 April 2011]
6. Advanced thermal solutions, available at <<http://qats.com/cms/2010/10/18/which-material-offers-the-best-thermal-conductivity-for-heat-sinks-and-thermal-management-applications-part-1-of-2/>> [Accessed 28 February 2012]
7. John H. Lienhard IV and John H. Lienhard V, A heat transfer textbook: Cambridge, Massachusetts.
8. Moataz Said Eissa, “Heat Exchangers Types and Applications”  
Available at <<http://www.scribd.com/doc/13242870/Types-of-Heat-Exchangers>> [Accessed 5 March 2011]
- 9 Argentum Solutions, Inc  
  
Available at < [http://www.argentumsolutions.com/tutorials/heat\\_tutorialpg4.html](http://www.argentumsolutions.com/tutorials/heat_tutorialpg4.html) >  
  
[Accessed 18 March 2011]
10. Plate heat exchangers, Available at < <http://www.altheating.com/exchangers.htm> > [Accessed 12 September 2011]

11. Schmidt Brazed Plate Heat Exchangers, available at  
<<http://www.apiheattransfer.com/us/Products/HeatExchangers/PlateHeatExchanger/BrazedPHE.htm>> [Accessed 1 October 2011]
12. Design Considerations for Shell and Tube Heat Exchangers, available at  
<<http://www.cheresources.com/designexzz.shtml>> [Accessed 12 November 2011]
13. Shell-and-Tube Heat Exchanger Screenshots, available at  
<<http://www.softpedia.com/progScreenshots/Shell-and-Tube-Heat-Exchanger-Screenshot-71424.html>> [Accessed 10 November 2011]
14. Heat Exchanger in Bio-Chemical Process. available at  
<<http://www.rpi.edu/dept/chem-eng/Biotech-Environ/FERMENT>> [Accessed 28 March 2011]
15. Salt Water Swimming Pool Heaters - CN-Series, available at  
<<http://www.heatexchangersonline.com/poolheaterscupro.htm>> [Accessed 10 November 2011]
16. Shell and tube heat exchanger, available at  
<[http://en.wikipedia.org/wiki/Shell\\_and\\_tube\\_heat\\_exchanger](http://en.wikipedia.org/wiki/Shell_and_tube_heat_exchanger)>
17. Specific heat of materials, available at  
<<http://www.monachos.gr/eng/resources/thermo/cp.htm>> [Accessed 7 November 2011]



## 9. Appendices

### Appendix 1

#### Conductivity table of various materials.

| Material          | Thermal conductivity<br>$k$<br>( $\text{W}\cdot\text{m}^{-1}\cdot\text{K}^{-1}$ ) |
|-------------------|---|
| <b>Metals</b>     |   |
| Iron              | 73  |
| Steel             | ~ 46  |
| Aluminum          | 210   |
| Copper            | 386   |
| Silver            | 406   |
| Gold              | 293   |
| Platinum          | 70  |
| Yellow Brass      | 85  |
| <b>Non Metals</b> |   |
| Asbestos          | 0.16  |
| Red Brick         | 0.63  |
| Cardboard         | 0.21  |
| Cement            | 0.30  |
| Earth's crust     | 1.7   |
| Felt              | 0.036   |
| Glass             | 0.8   |
| Fiberglass        | 0.04  |
| Granite           | 2.1   |
| Ice               | 2.2   |
| Linen             | 0.088   |
| Paper             | 0.13  |
| Rubber, soft      | 0.14  |
| Sand, dry         | 0.39  |
| Silk              | 0.04  |
| Snow, compact     | 0.21  |
| Soil, dry         | 0.14  |
| Wood              | 0.13  |
| <b>Liquids</b>    |   |
| Acetone           | 0.20  |
| Alcohol, ethyl    | 0.17  |

|                 |       |
|-----------------|-------|
| Mercury         | 8.7   |
| Oil, engine     | 0.15  |
| Vaseline        | 0.18  |
| Water           | 0.58  |
| <b>Gases</b>    |       |
| Air             | 0.026 |
| CO <sub>2</sub> | 0.017 |
| Nitrogen        | 0.026 |
| Oxygen          | 0.027 |

## Appendix 2

### Specific heat of various materials

| Material             | Specific heat $c_p$<br>( J/ kg x °K ) |
|----------------------|---------------------------------------|
| <b>Solids</b>        |                                       |
| Aluminum             | 900                                   |
| Copper               | 390                                   |
| Glass                | 840                                   |
| Human body (average) | 3470                                  |
| Iron                 | 470                                   |
| Marble               | 860                                   |
| Silver               | 230                                   |
| Stainless Steel      | 500                                   |
| Wood                 | 1800                                  |
| <b>Liquids</b>       |                                       |
| Alcohol (ethyl)      | 2400                                  |
| Ammonia              | 4710                                  |
| Water                | 4186                                  |
| <b>Gases</b>         |                                       |
| Air (100 °C)         | 1000                                  |
| Carbon dioxide       | 1000                                  |
| Hydrogen             | 14200                                 |
| Methane              | 2200                                  |
| Steam (110 °C)       | 2100                                  |