

Saimaa University of Applied Sciences
Technology / Imatra
Degree Programme in Chemical Engineering

Cui Wenjuan

Extraction of Scots Pine with Non-polar Solvents

Bachelor's Thesis 2013

Abstract

Cui Wenjuan

Extraction of Scots Pine with Non-polar Solvents, 44 pages

Saimaa University of Applied Sciences

Technology / Imatra

Degree Programme in Chemical Engineering

Bachelor's Thesis 2013

Supervisor: Päivi Riikonen, M.Sc., Lic.Tech., Saimaa UAS

The purpose of this paper was to understand wood structure and its chemical distribution so that the method that extractives are separated from woods was gained. In addition, the separation process of extractives and how to compare the results of gas chromatography were also studied in this thesis work. The study was commissioned and supervised by Päivi Riikonen.

The experiment was carried out in Saimaa University of Applied Sciences, Imatra, Finland. The raw materials used in the study were Scots pine stem chips, extracted and separated with a non-polar solvent hexane in different time periods, and finally identified by gas chromatography.

The results of the study show that the extraction time is not necessarily advantageous, it is possible it would make some extractives decompose or react to other compounds when the time of extraction exceeds a certain time. And some results from GC analysis and theoretical analysis will be got. Further study is required to identify the components of extractives.

Keywords: extractives, hexane, Scots pine, stem chips, isolation, gas chromatography, lipophilic extractives, phenolic extractives

CONTENTS

1	INTRODUCTION	5
2	SCOTS PINE	5
3	STRUCTURE OF A TREE	7
3.1	Introduction.....	7
3.2	Structure of wood	8
3.2.1	Softwoods and hardwoods	8
3.2.2	Sapwood and heartwood	9
3.2.3	Axial and radial systems	10
3.2.4	Planes of section	10
3.2.5	Vascular cambium	11
3.2.6	Cells in wood	12
3.2.7	Cell walls	12
3.2.8	Pits	13
4	CHEMICAL COMPOSITION AND DISTRIBUTION	13
4.1	Gross composition	13
4.2	Extractives	14
4.2.1	Lipophilic extractives	15
4.2.1.1	Resin acids	16
4.2.1.2	Fatty acids	16
4.2.1.3	Triglycerides	17
4.2.1.4	Sterols	17
4.2.2	Phenolic extractives.....	18
4.2.2.1	Lignans	18
4.2.2.2	Stibenoids.....	18
4.2.2.3	Flavonoids	19
4.2.2.4	Tannin	19
5	GAS CHROMATOGRAPHY	20
5.1	Introduction.....	20
5.2	Carrier gas.....	22
5.3	Detectors	22
5.4	Column selection	23
5.5	Sample injection port	23

6	EXPERIMENTAL PART.....	24
6.1	Raw materials selection and pretreatment.....	24
6.2	Solvent selection	25
6.3	Extraction process	26
6.3.1	Calculation of the mass of pine chips	26
6.3.2	The preparation of extraction.....	27
6.3.3	Determination of the mass percentages of extractives in chips	27
6.3.4	Pretreatment of extraction solution	28
6.4	The operation of GC	28
6.5	Results and discussions	30
6.5.1	The mass percentages of extractives in chips	30
6.5.2	The results and discussions of GC analysis	31
	6.5.2.1 GC analysis of the results in Cui Wenjuan’s experiments	31
	6.5.2.2 Comparison of the results in Cui Wenjuan’s and Li Xiaofeng’s experiments.....	32
	6.5.2.3 Comparison of the results in Cui Wenjuan’s and Li Yuman’s experiments.....	33
7	SUMMARY	34
	REFERENCES.....	35
	APPENDIX 1	
	APPENDIX 2	
	APPENDIX 3	
	APPENDIX 4	

1 INTRODUCTION

The extractives are important when considering various technical aspects. They constitute valuable raw materials for making organic chemicals, and some classes of extractives play an important role in the pulping and papermaking processes. In this study, the extractives were extracted from the Scots pine stem chips.

Extractives comprise an extraordinarily large number of diverse substances (i.e., several thousands of individual compounds), mainly with low molecular masses. By a broad definition, these extractives are either soluble in neutral organic solvents (e.g., diethyl ether, methyl tert-butyl ether, petroleum ether, dichloromethane, acetone, ethanol, methanol, hexane, toluene, and tetrahydrofuran (THF) or water). Thus, the hexane was adapted as the solvent in this study.

Extractives were isolated with non-polar solvent under different operating times, the liquid samples from extraction process were analyzed by GC analysis. And the mass percentages of extractives were determined by drying in the oven. In theoretical preparation and analysis of the experimental results, some experimental results which can achieve our purposes of the study were gained.

2 SCOTS PINE

Scots pine (*Pinus sylvestris* L.) is the most widely distributed conifer species in the world (Nicolov & Helmisaari 1992), with a natural range stretching from Spain to Norway and from Scotland to Siberia (Mason 2000). Natural forests or plantations of this species are found in most member states of the EU and it is of considerable importance as a timber producing species, particularly in Nordic countries (Mason & Alia 2000). There are more than 28 million hectares of Scots pine forests in Europe, representing the region of 20% of the commercial forest area of the EU. The importance of Scots pine in the Northern Periphery Programme area can be seen in Table 1.

Table 1 Proportion of the total forest area comprising Scots pine in each of the project partner countries (National Forest Inventories of participating countries 2011.)

Country	Area of Scots pine Forest ('000 ha)	Area of Scots pine Forest as a Proportion of Total Forest Area	
		Entire Country	NPP Area
Finland	13000	65%	68%
Norway	1657	22%	16%
Scotland	136	12%	22%
Sweden	9000	53%	62%

Unsurprisingly, given the extent of their Scots pine forest area, Finland and Sweden dominate the production of Scots pine timber from EU countries, accounting for more than 80% of the annual cut (Mason & Alía 2000). A recent report reviewed markets for Scots pine timber in the Northern Periphery Programme areas of Finland, Norway, Scotland and Sweden (Gjerdrum 2009): the main end uses are shown in Table 2. In the Nordic countries around half of the Scots pine round wood produced is processed as pulpwood, with a similar proportion used for wood based panel production in Scotland. Whilst construction and joinery are important markets for sawn timber in Finland, Norway and Sweden, these sectors account for less than 5% of the Scottish sawn timber supply which is predominantly used for fencing.

Table 2 Main end uses of Scots pine timber in each of the Northern Periphery countries

Finland	Norway	Scotland	Sweden
<ul style="list-style-type: none"> • Pulpwood (55%) • Construction • Interior joinery and linings • Transmission poles • Log houses 	<ul style="list-style-type: none"> • Pulpwood (45%) • Construction • Joinery • Fencing • Transmission poles • Log houses 	<ul style="list-style-type: none"> • Wood based panels (50%) • Fencing (45%) • Construction • Decking 	<ul style="list-style-type: none"> • Pulpwood (40%) • Packaging (25%) • Construction • Joinery • Fuel wood

3 STRUCTURE OF A TREE

Any vascular plant is a tree if it has clearly recognizable crown, stem, and root systems. The plant therefore has a tree-like structure with balance relationship among different structural components, which include the crown (foliage and branches), stem and roots (coarse and fine roots). The proportions of components to the total biomass vary between species and also within species during the life span. In young trees, the proportion of foliage is larger than in older trees, and the proportion of the stem increases with age. The proportion of the stem of the entire tree biomass is usually 50% - 60%, that of roots 10% - 25%, that of branches is 10% - 20%, and that of foliage less than 10%. (Kellomäki 2009.)

3.1 Introduction

The concept of tree normally refers to woody plants with the above properties and appropriate size. For trees, this implies that the vascular cambium or cambium forms a continuous layer around the stem with formation of xylem (wood) inwards and phloem (bark) outwards, as shown in Figure 1. (Kellomäki 2009.)

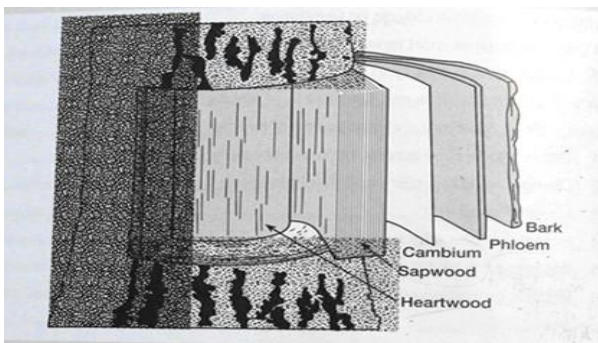

Figure 1 Main structure of the wood stem of trees in the boreal and temperate zones.

Cambium is the layer of living cells forming wood (xylem) inwards and bark outwards. Phloem refers to the living part of bark, and sapwood to the outer part of stem wood conducting water, and heartwood to the inner part of stem wood not conducting water and in many cases with a darker color than the sapwood. (Kellomäki 2009, p.16)

In forestry, the primary focus is normally on the stem of the tree because of its economic value. In the functioning of a tree, the stem connects the foliage to the soil system and together with the branches provides a framework for foliage to absorb radiation to drive the photosynthesis and other physiological processes. The stem is normally a cylinder tapering upwards formed by annual layers of radial growth (annual rings) (Figure 2). The distribution of wood density follows the distribution of radial growth such that wide annual rings indicate low wood density and vice versa. (Kellomäki 2009.)

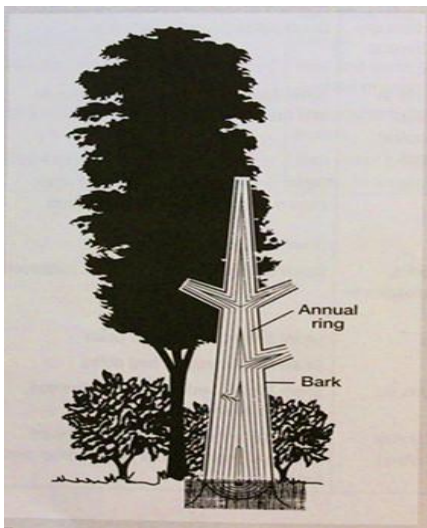

Figure 2 Schematic presentation of tree structure (Kellomäki 2009, p.24)

3.2 Structure of wood

Wood, instead of being a relatively solid material like steel or concrete, is basically composed of many tubular fiber units, or cells, cemented together. Many properties of wood are related directly to its structure. The following descriptions explain the distinguishing cellular characteristics of a hardwood and a softwood. (United States Department of Agriculture.)

3.2.1 Softwoods and hardwoods

Softwoods have a simpler basic structure than do hardwoods because they have only two cell types and relatively little variation in structure within these cell types. Hardwoods have greater structural complexity because they have both a greater number of basic cell types and a far greater degree of variability within the cell types. The single most important distinction between the two general kinds of wood is that

hardwoods have a characteristic type of cell called a vessel element (or pore) whereas softwoods lack these (Figure 3). An important cellular similarity between softwoods and hardwoods is that in both kinds of wood, most of the cells are dead at maturity, even in the sapwood. The cells that are alive at maturity are known as parenchyma cells and can be found in both softwoods and hardwoods. (Wiedenhoef & Miller 2005.)

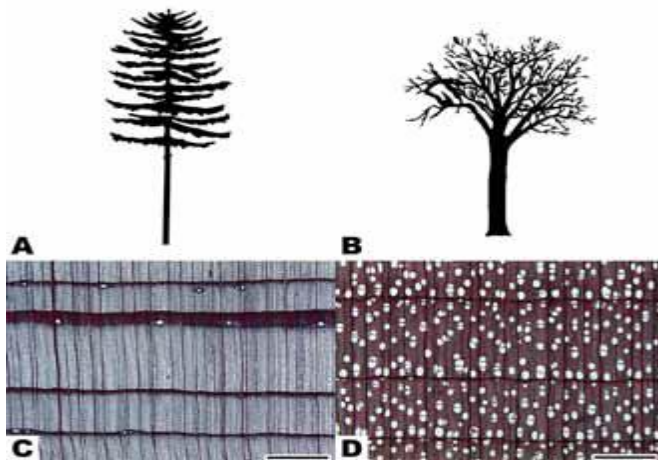

Figure 3 Structure of softwood/hardwood (Wiedenhoef & Miller 2005)

A, the general form of a generic softwood tree. B, the general form of a generic hardwood tree. C, transverse section of *Pseudotsuga mensiezii*, typical softwood; the thirteen round white spaces are resin canals. D, transverse section of *Betula allegheniensis*, typical hardwood; the many large, round white structures are vessels or pores, the characteristic feature of a hardwood. Scale bars = 780 μm . (Wiedenhoef & Miller 2005, 3-3)

3.2.2 Sapwood and heartwood

In both softwoods and hardwoods, the wood in the trunk of the tree is typically divided into two zones, each of which serves an important function distinct from the other. The actively conducting portion of the stem in which parenchyma cells are still alive and metabolically active is referred to as sapwood. A looser, more broadly applied definition is that sapwood is the band of lighter colored wood adjacent to the bark. Heartwood is the darker colored wood found to the interior of the sapwood (Figure 1). (Wiedenhoef & Miller 2005.)

In the living tree, sapwood is responsible not only for conduction of sap but also for

storage and synthesis of biochemicals. An important storage function is the long-term storage of photosynthate. Living cells of the sapwood are also the agents of heartwood formation. Biochemicals must be actively synthesized and translocated by living cells. Heartwood functions in long-term storage of biochemicals of many varieties depending on the species in question. These chemicals are known collectively as extractives. Now it is known that extractives are a normal part of the plant's system of protecting its wood. Extractives are formed by parenchyma cells at the heartwood–sapwood boundary and are then exuded through pits into adjacent cells (Hillis 1996).

3.2.3 Axial and radial systems

The cells of wood are typically many times longer than wide and are specifically oriented in two separate systems of cells: the axial system and the radial system. Cells of the axial system have their long axes running parallel to the long axis of the organ (up and down the trunk). Cells of the radial system are elongated perpendicularly to the long axis of the organ and are oriented like radii in a circle or spokes in a bicycle wheel, from the pith to the bark. In the trunk of a tree, the axial system runs up and down, functions in long-distance water movement, and provides the bulk of the mechanical strength of the tree. The radial system runs in a pith to bark direction, provides lateral transport for biochemicals, and in many cases performs a large fraction of the storage function in wood. These two systems are interpenetrating and interconnected, and their presence is a defining characteristic of wood as a tissue. (Wiedenhoeft & Miller 2005.)

3.2.4 Planes of section

Although wood can be cut in any direction for examination, the organization and interrelationship between the axial and radial systems give rise to three main perspectives from which they can be viewed to glean the most information. These three perspectives are the transverse plane of section (the cross section), the radial plane of section, and the tangential plane of section. Radial and tangential sections are referred to as longitudinal sections because they extend parallel to the axial system (along the grain) (Figure 4).

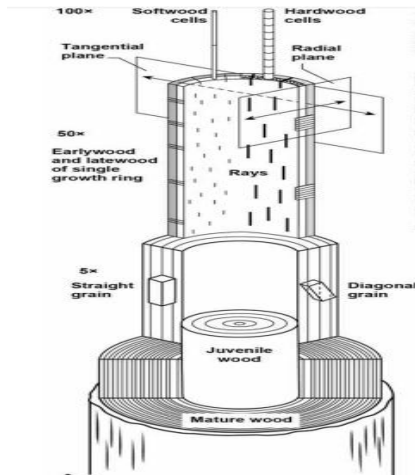

Figure 4 Illustration of a cut-away tree at various magnifications (Wiedenhoef & Miller 2005, 3-5)

3.2.5 Vascular cambium

The axial and radial systems and their component cells are derived from a part of the tree called the vascular cambium. The vascular cambium is a thin layer of cells that exists between the inner bark and the wood (Figure 5) that produces, by means of many cell divisions, wood (or secondary xylem) to the inside and bark (or secondary phloem) to the outside, both of which are vascular conducting tissues (Larson 1994). As the vascular cambium adds cells to the layers of wood and bark around a tree, the girth of the tree increases, and thus the total surface area of the vascular cambium itself must increase, and this is accomplished by cell division as well.

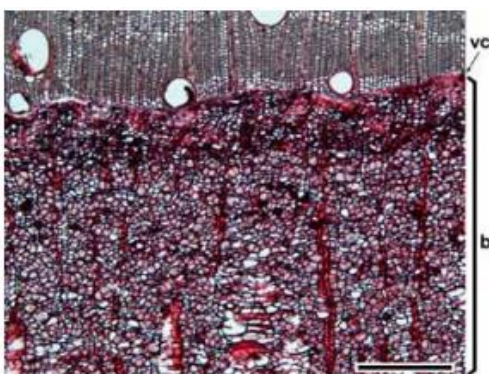

Figure 5 Light microscopic view of the vascular cambium. Transverse section showing vascular cambium (vc) and bark (b) in *Croton macrobothrys*. The tissue above the vascular cambium is wood. Scale bar = 390 μm . (Wiedenhoef & Miller 2005, 3-6)

The axial and radial systems are generated in the vascular cambium by two component cells: fusiform initials and ray initials. Fusiform initials, named to describe their long, slender shape, give rise to cells of the axial system, and ray initials give rise to the radial system. (Wiedenhoef & Miller 2005.)

3.2.6 Cells in wood

A living plant cell consists of two primary domains: the protoplast and the cell wall. The protoplast is the sum of the living contents that are bound by the cell membrane. The cell wall is a non-living, largely carbohydrate matrix extruded by the protoplast to the exterior of the cell membrane. The plant cell wall protects the protoplast from osmotic lysis and often provides mechanical support to the plant at large. (Esau 1977) (Raven et al. 1999) (Dickison 2000)

3.2.7 Cell walls

Cell walls in wood give wood the majority of its properties discussed in later chapters. The cell wall itself is a highly regular structure, from one cell type to another, between species, and even when comparing softwoods and hardwoods. The cell wall consists of three main regions: the middle lamella, the primary wall, and the secondary wall (Figure 6). In each region, the cell wall has three major components: cellulose microfibrils (with characteristic distributions and organization), hemicelluloses, and a matrix or encrusting material, typically pectin in primary walls and lignin in secondary walls. (Panshin & deZeeuw 1980.)

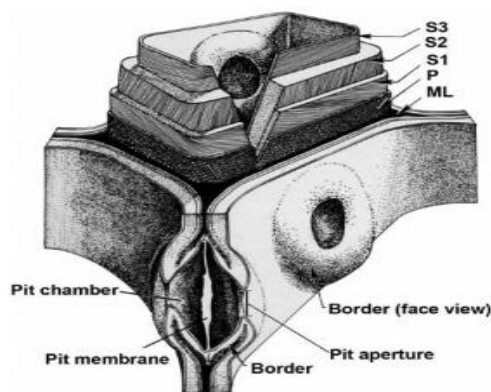

Figure 6 Cut-away drawing of the cell wall, including the structural details of a bordered pit.

The various layers of the cell wall are detailed at the top of the drawing, beginning

with the middle lamella (ML). The next layer is the primary wall (P), and on the surface of this layer the random orientation of the cellulose microfibrils is detailed. Interior to the primary wall is the secondary wall in its three layers: S1, S2, and S3. (Wiedenhoeft & Miller 2005, 3-7)

3.2.8 Pits

Any discussion of cell walls in wood must be accompanied by a discussion of the ways in which cell walls are modified to allow communication and transport between the cells in the living plant. These wall modifications, called pit-pairs (or more commonly just pits), are thin areas in the cell walls between two cells and are a critical aspect of wood structure too often overlooked in wood technological treatments. Pits have three domains: the pit membrane, the pit aperture, and the pit chamber (Figure 6). (Wiedenhoeft & Miller 2005.)

4 CHEMICAL COMPOSITION AND DISTRIBUTION

The major chemical constituents of all wood species are so-called “structural substances”: cellulose, hemicellulose, and lignin. Other polymeric constituents present in lesser and often varying quantities are pectin, starch, and proteins. In addition to these macromolecular components, various “nonstructural” and mostly low-molecular-mass compounds (extractives, some water-soluble organics, and inorganics) can be found in small quantities in both softwoods and hardwoods. (Stenius 2000.)

4.1 Gross composition

The gross chemical composition of the stemwood (i.e., a common result of wood analysis) differs somewhat from that of the other macroscopic parts of the tree. (Stenius 2000.)

The moisture content of a living tree varies seasonally and even diurnally depending on the weather. The average values are in the range of 40%-50% of the total wood mass. It is accepted as a common fact that approximately two-thirds of the dry matter of wood is composed of polysaccharides, i.e., cellulose and various hemicelluloses. However, when studied in more detail, for softwoods and hardwoods, the cellulose content is more or less the same (40%-45% of the wood dry solids), but softwoods usually contain less hemicelluloses and more lignin. (Stenius 2000.)

It is also typical that the structure of hemicelluloses (analogous to lignin) is different between softwoods and hardwoods, while cellulose is a uniform component of all woods. In addition, the extractives-based components found in these two wood groups vary to some extent both in structure and amount. Figure 7 illustrates a typical gross chemical composition of commercial softwood (Scots pine) and hardwood (Betula pendula). (Stenius 2000.)

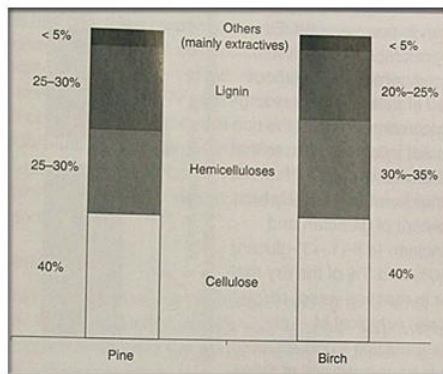

Figure 7 Average chemical composition of Scots pine (*Pinus sylvestris*) and silver birch (*Betula pendula*). As a percentage of the wood dry solids. (Stenius 2000, p.29)

4.2 Extractives

In general a tree consists of sapwood and heartwood. These two tissue types consist mainly of cellulose, hemicellulose, lignin and table 3 describes roughly how they are distributed in spruce and pine. (Canadian Wood Association.)

Table 3 Chemical constituents and their approximate percentage in spruce and pine (Canadian Wood Association)

Tree species	Cellulose %	Hemicellulose %	Lignin %	Extractives %	Other %
Spruce	39.5	30.6	27.5	2.1	0.3
Pine	40.0	28.5	27.7	3.5	0.3

The tree also consists of extractives like fatty acids, resin acids and glycerides that are used mainly for protection against insects, microorganisms decay, and fungus

attack if the protecting bark is injured (SLU 1999) (Wålinder 2000). Another very important thing is that the extractives are used as nutrition and are stored inside the tree.

Extractives, resin, are a heterogeneous group of different compounds and constitute between 1-4 % of the tree's total dry matter but still they are necessary for the survival of the tree. They are intractable in acidic environments. Some of these extractives are volatile and in general nonpolar (polar extractives can also be present), low molecular weight compounds with different chemical behaviors. (Peng et al 2010.) Extractives are removed from both wood and pulp by organic solvents such as acetone, hexane, ethanol, ether, or dichloromethane. They are composed principally of lipids and related compounds, e.g., glycerides, sterol esters, fatty acids, resin acids, fatty alcohols, sterols, and alkanes. (Mutton 1962.) (Allen 1978.) The concentration and composition of such lipid mixtures vary among wood species, within and among trees, with tree age, and with environmental conditions (Hillis & Sumimoto 1989).

In comparison of chips from spruce- and pine thinning, three to five times more extractives are found in pine than in spruce, that is because the pine has a greater average size of the parenchyma cells which makes it possible for more storing of extractives (Fernando et al. 2007).

4.2.1 Lipophilic extractives

Resin acids, fatty acids, triglycerides, sterols and their esters are the main lipophilic groups of extractives in spruce and pine. Triglycerides dominate the sapwood in both spruce and pine while the amount of resin acids is higher in the heartwood of pine. (Fernando et al. 2007.) In pine there are around two times more resin acids in the heartwood compared to the sapwood. There are almost no triglycerides in the heartwood of pine, instead there is a large amount of free fatty acids. (Assarsson & Åkerlund 1970) And boiling points of different type of lipophilic extractives are listed in Table 4.

Table 4 Boiling points of chemical compounds (Ophardt 2003)

The type of lipophilic extractives	Boiling point
Resin acids	217 – 240 °C
Fatty acids	162 – 338.58 °C ⁴²
Triglycerides	350 – 400 °C (Goodrum & Geller 2002)
Monoterpene	150 – 185 °C
Sesquiterpene	223 – 235 °C
Diterpene	347 – 400 °C
Triterpene (steroids)	71 – 210 °C

4.2.1.1 Resin acids

Resin acids have a lipophilic carbon skeleton and a hydrophilic carboxyl group. This basic skeleton, a 3-ring system, is shared by almost all the acids. They are tricyclic compounds of abietan- or primaran type. In figure 8 the molecular structure of abietic acid is shown. High amounts of the acids are located in the canal resin of the wood.

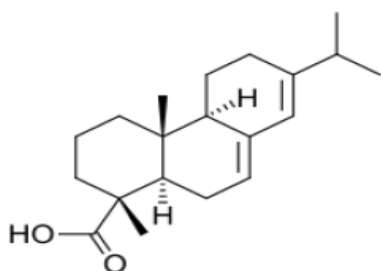

Figure 8 The molecular structure of abietic acid (aBitAbout)

4.2.1.2 Fatty acids

Fatty acids are long chains of aliphatic monocarbon acids with chain lengths of 10-24 carbon atoms. They can be either saturated or unsaturated. The saturated ones are chemically very stable compounds while the double bonds present in the unsaturated fatty acids make them susceptible to oxidation- and additional reactions. In figure 9 two fatty acids are shown. Fatty acids often come esterified in the wood extractives. (Croon 1969.)

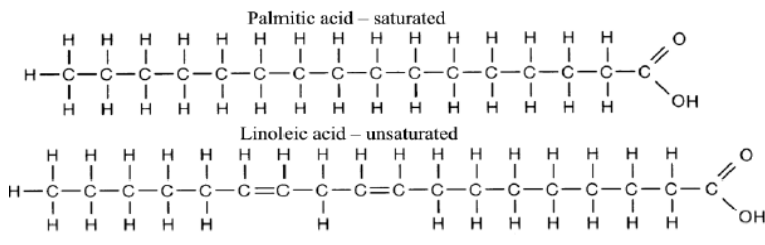

Figure 9 The molecular structure of palmitic acid (saturated) and linoleic acid (unsaturated)

4.2.1.3 Triglycerides

Triglycerides are a type of fat composed by one molecule of glycerol and three fatty acids. Ester bonds are formed when the carboxyl groups of the fatty acids connect to the hydroxyl groups of the glycerol. (Scientific Psychic.) When heartwood is formed, the triglycerides are hydrolyzed to free fatty acids. Large amount of these are found in the heartwood and it is highly likely that some of these fatty acids metabolize to heartwood-phenols like pinosylvin and pinosylvin monomethylether. (Assarsson & Åkerlund 1970.)

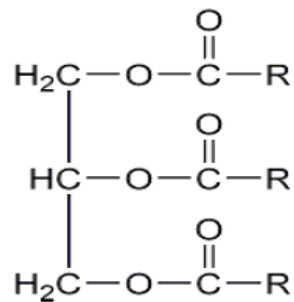

Figure 10 The molecular structure of a triglyceride (Chemryb)

4.2.1.4 Sterols

Sterols are ordinary oxygenous compounds. Hydroxyl groups are usually a part of their structures. Sterols are difficult to chemically modify in order to make it easier to the removal from the pulp. The most common sterol in wood is β -sitosterol, see figure 11. (Croon 1969)

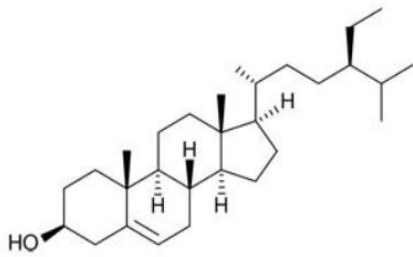

Figure 11 The molecular structure of β -sitosterol (Prostate Miracle)

4.2.2 Phenolic extractives

The other major group of wood extractives includes compounds with phenol units in their structure. Phenol as such is not found in extractives. The color found in heartwood, as well as the toxic or repellent properties for biotic attackers, come mostly from phenol-based compounds. (Barnett & Jeronimidis 2003.)

4.2.2.1 Lignans

One of the main groups of phenolic extractives, present both in softwoods and hardwoods, is the lignans. Lignans consist of two linked phenylpropanoid units, often similar to the dimeric structures found in lignin. Some of the most common lignans have β -O-4 and β - β linkages between the monomers, making the tetrahydrofuran ring, as in the pinoresinol from softwoods and the syringaresinol from hardwoods. (Figure 12)

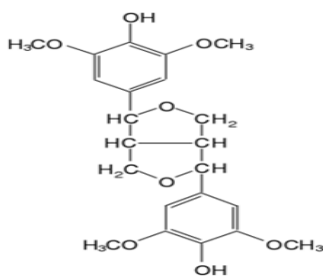

Figure 12 Syringaresinol (Barnett & Jeronimidis 2003)

4.2.2.2 Stibenoids

Stibenoids (Figure 13) are found mostly in the heartwood of pines and are one of the types of extractives that have been proven to inhibit the growth of fungi and be formed as a response to insect attack (Gorham 1995). The presence of stibenoids is

a problem for some wood uses, being responsible for the light-induced darkening of wood and also difficulties in producing pulp for paper.

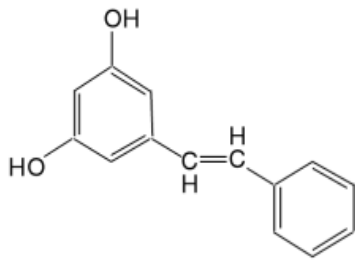

Figure 13 Pinosylvin (Barnett & Jeronimidis 2003)

4.2.2.3 Flavonoids

Another important group of phenolic extractives found in wood is the flavonoids. Flavonoids are $C_6-C_3-C_6$ three ring structures, and the structure of the central ring defines different classes of flavonoids: flavones, flavanes, flavanones, isoflavones, chalcones, aurones. Substitutions of hydroxyl and methoxyl groups in the two aromatic rings define the individual flavonoids. Catechin, a flavane, is one of the more widespread flavonoids. (Figure 14) The colors found in the heartwood are in many cases related to their flavonoid extractives. Flavonoids exist in wood as such, as glycosides and also in oligomeric and polymeric forms. (Harborne 1989.)

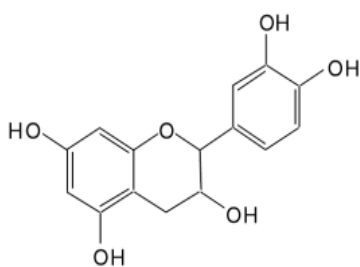
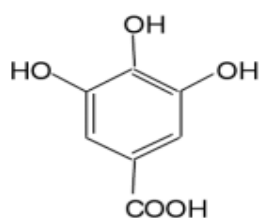

Figure 14 Catechin (Barnett & Jeronimidis 2003)

4.2.2.4 Tannin

Flavanes like catechin (flavan-3-ol) and leucocyanidin (flavan-3,4-diol) condense in dimeric forms, as biflavonoids (proanthocyanidins), or in higher degree to form polyflavonoids known as condensed tannins. The other type of tannins present in

wood is the hydrolyzable tannins, named as such because they are hydrolyzed to monomers with acids. They are esters of gallic acid (Figure 15, a) and of its dimers, digallic and ellagic acids (Figure 15, b), with sugars, usually glucose. Wood tannins, known for their tanning properties of animal skin, can have adverse consequences in gluing wood and pulp production. (Barnett & Jeronimidis 2003.)



a)

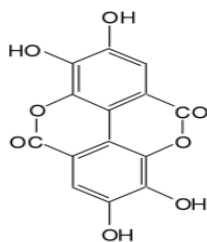

b)

Figure 15 a) gallic acid. b) ellagic acid (Barnett & Jeronimidis 2003)

5 GAS CHROMATOGRAPHY

Gas chromatography (GC), is a common type of chromatography used in analytical chemistry for separating and analyzing compounds that can be vaporized without decomposition.

5.1 Introduction

Typical uses of GC include testing the purity of a particular substance, or separating the different components of a mixture (the relative amounts of such components can also be determined). In some situations, GC may help in identifying a compound.

In preparative chromatography, GC can be used to prepare pure compounds from a mixture. (Pavia et al. 2006.) (Linde.)

In gas chromatography, the mobile phase (or "moving phase") is a carrier gas, usually an inert gas such as helium or an unreactive gas such as nitrogen. The stationary phase is a microscopic layer of liquid or polymer on an inert solid support, inside a piece of glass or metal tubing called a column (a homage to the fractionating column used in distillation). The instrument used to perform gas chromatography is called a gas chromatograph (or "aerograph", "gas separator"). (Wikipedia.)

In a GC analysis, a known volume of gaseous or liquid analyte is injected into the

"entrance" (head) of the column, usually using a microsyringe (or, solid phase microextraction fibers, or a gas source switching system). As the carrier gas sweeps the analyte molecules through the column, this motion is inhibited by the adsorption of the analyte molecules either onto the column walls or onto packing materials in the column. The rate at which the molecules progress along the column depends on the strength of adsorption, which in turn depends on the type of molecule and on the stationary phase materials. Since each type of molecule has a different rate of progression, the various components of the analyte mixture are separated as they progress along the column and reach the end of the column at different times (retention time). A detector is used to monitor the outlet stream from the column; thus, the time at which each component reaches the outlet and the amount of that component can be determined. Generally, substances are identified (qualitatively) by the order in which they emerge (elute) from the column and by the retention time of the analyte in the column. (Figure 16) (Wikipedia.)

The gaseous compounds being analyzed interact with the walls of the column, which is coated with a stationary phase. This causes each compound to elute at a different time, known as the retention time of the compound. Other parameters that can be used to alter the order or time of retention are the carrier gas flow rate, column length and the temperature. The comparison of retention times is what gives GC its analytical usefulness. Gas chromatography is also similar to fractional distillation, since both processes separate the components of a mixture primarily based on boiling point (or vapor pressure) differences. However, fractional distillation is typically used to separate components of a mixture on a large scale, whereas GC can be used on a much smaller scale (i.e. microscale). (Pavia et al. 2006.)

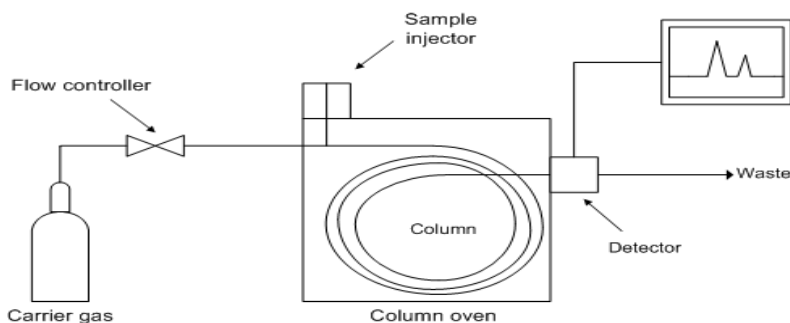

Figure 16 Diagram of a gas chromatograph (Wikipedia)

5.2 Carrier gas

The column inlet (or injector) provides the means to introduce a sample into a continuous flow of carrier gas. The inlet is a piece of hardware attached to the column head. The choice of carrier gas (mobile phase) is important, hydrogen has a larger range of flowrates that are comparable to helium in efficiency. However, helium may be more efficient and provide the best separation if flow rates are optimized. Helium is non-flammable, and works with a greater number of detectors and older instruments. Therefore, helium is the most common carrier gas used. However, the price of helium has gone up considerably over recent years, causing an increasing number of chromatographers to switch to hydrogen gas. Historical use rather than rational consideration may contribute to the continued preferential use of helium. (Wikipedia.)

5.3 Detectors

The most commonly used detectors are the flame ionization detector (FID) and the thermal conductivity detector (TCD). Both are sensitive to a wide range of components, and both work over a wide range of concentrations. While TCDs are essentially universal and can be used to detect any component other than the carrier gas (as long as their thermal conductivities are different from that of the carrier gas, at detector temperature), FIDs are sensitive primarily to hydrocarbons, and are more sensitive to them than TCD. However, an FID cannot detect water. Both detectors are also quite robust. Since TCD is non-destructive, it can be operated in-series before an FID (destructive), thus providing complementary detection of the same analytes. (ACRF.)

Other detectors are sensitive only to specific types of substances, or work well only in narrower ranges of concentrations. They include: Catalytic combustion detector (CCD), Discharge ionization detector (DID), Flame photometric detector (FPD), Atomic Emission Detector (AED), Hall electrolytic conductivity detector (EICD), Helium ionization detector (HID), Nitrogen–phosphorus detector (NPD), Infrared detector (IRD), Mass spectrometer (MS), Photo-ionization detector (PID), Pulsed discharge ionization detector (PDD), Thermionic ionization detector (TID). (Wikipedia.)

5.4 Column selection

The choice of column depends on the sample. The main chemical attribute regarded when choosing a column is the polarity of the mixture, and functional groups can play a large part in column selection. The polarity of the sample must closely match the polarity of the column stationary phase to increase resolution and separation while reducing run time. The separation and run time also depends on the film thickness (of the stationary phase), the column diameter and the column length.

The polarity of the solute is crucial for the choice of stationary compound, which in an optimal case would have a similar polarity as the solute. Common stationary phases in open tubular columns are cyanopropylphenyl dimethyl polysiloxane, carbowax polyethyleneglycol, biscyanopropyl cyanopropylphenyl polysiloxane and diphenyl dimethyl polysiloxane. For packed columns more options are available. (Harris 1999.)

The column(s) in a GC are in an oven, the temperature of which is precisely controlled electronically. When discussing the "temperature of the column," an analyst is technically referring to the temperature of the column oven. The rate at which a sample passes through the column is directly proportional to the temperature of the column. The higher the column temperature, the faster the sample moves through the column. However, the faster a sample moves through the column, the less it interacts with the stationary phase, and the less the analytes are separated. (Wikipedia.)

However, increasing the column temperature during the analysis, also the initial temperature, rate of temperature or the temperature "ramp" and final temperature is called the "temperature program." A temperature program allows analytes that elute early in the analysis to separate adequately, while shortening the time it takes for late-eluting analytes to pass through the column. (Wikipedia.)

5.5 Sample injection port

For optimum column efficiency, the sample should not be too large, and should be introduced onto the column as a "plug" of vapor - slow injection of large samples causes band broadening and loss of resolution. The most common injection method is where a microsyringe is used to inject sample through a rubber septum into a flash

vaporizer port at the head of the column. The temperature of the sample port is usually about 50°C higher than the boiling point of the least volatile component of the sample. For packed columns, sample size ranges from tenths of a microliter up to 20 microliters. Capillary columns, on the other hand, need much less sample, typically around 10^{-3} mL. For capillary GC, split/splitless injection is used. Have a look at this diagram of a split/splitless injector (Figure 17). (Sheffield Hallam University.)

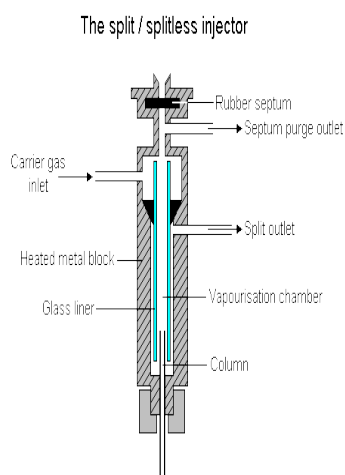

Figure 17 The split/splitless injection

The injector can be used in one of two modes; split or splitless. In this thesis, the mode of split was used. The injector contains a heated chamber containing a glass liner into which the sample is injected through the septum. The carrier gas enters the chamber and can leave by three routes (when the injector is in split mode). The sample vaporizes to form a mixture of carrier gas, vaporized solvent and vaporized solutes. A proportion of this mixture passes onto the column, but most exits through the split outlet. The septum purge outlet prevents septum bleed components from entering the column. (Sheffield Hallam University.)

6 EXPERIMENTAL PART

Based on the theoretical section, the following is experimental part. In the experiment, the purpose and results of the experiment were obtained.

6.1 Raw materials selection and pretreatment

The proportions of components to the total biomass vary between species and also within species during the life span. The proportion of the stem of the entire tree

biomass is usually 50% - 60%. In forestry, the primary focus is normally on the stem of the tree because of its economic value. If you compare chips from spruce- and pine thinning, three to five times more extractives are found in pine than in spruce, that is because the pine have a greater average size of the parenchyma cells which makes it possible for more storing of extractives, which have been introduced in Chapter 4.2. Therefore, the raw materials were Scots pine stem chips available in Saimaa University of Applied Sciences.

Scots pine stem chips were sealed to keep them fresh. The stem had to be cut into an appropriate size for further extraction, the appropriate sizes of chips were from 5*10*3 mm to 15*20*3 mm (length*width*thickness). (Figure 18) Cutting work was carried out in the Saimaa University laboratory using different tools, such as axes and scissors.



Figure 18 Scots pine stem chips

6.2 Solvent selection

The term “wood extractives” includes a wide variety of components that can be extracted from wood with various organic solvents. The choice of extraction solvent is very critical. Different solvents are needed for different purposes. For quantitative determinations, complete extraction of the components of interest is an absolute demand. For gravimetric determination, the extraction solvent should furthermore be selective, that is, extract only the components of interest. For example, acetone can give complete extraction of wood resin components, but it also extracts other compounds. Nonpolar solvents, such as alkanes, selectively extract lipophilic wood resin components, but do not always give complete extraction. Solvents with intermediate polarity, e.g., ethers, dichloromethane, chloroform, or aromatic hydrocarbons, will extract some polar components in addition to the true wood resin components. The amount and composition of extractives, therefore, should always

be assessed with due consideration of the solvent used. (Stenius 2000.)

In this thesis, hexane was used. Hexane is considered to be the best solvent because of its beneficial commercial price, edibility of the various products obtained from extraction, stable physical properties and its low boiling point - 69 °C / 156.2 °F. And its density is 0.66 kg/L. It is insoluble into the water and it can be miscible with alcohol and ether. N-hexane is a volatile liquid easily evaporated into air, and it must be stored in a proper vessel that is designed for inflammable liquid. (Wade 2003.)

6.3 Extraction process

Extraction process was carried out in laboratory in Saimaa University of Applied Sciences. Extractives were isolated with non-polar solvent under different operating time, the equipment was round – bottom flask with reflux condenser, as shown in Figure 19.



Figure 19 The round – bottom flask with reflux condenser in this experiment

6.3.1 Calculation of the mass of pine chips

The mass ratio of stem chips and hexane was 1:3. The volume of the solution was set as 0.2 dm³, and the mass of hexane can be derived from density and volume, so the mass of stem chips can be calculated from the following formula (1):

$$\frac{m_{\text{chips}}}{\rho_{\text{hexane}} * V_{\text{hexane}}} = \frac{1}{3} \quad (1)$$

Given: $\rho_{\text{hexane}} = 660 \text{ kg/dm}^3$.

$$\text{Then, } m_{\text{chips}} = \frac{660 * 200}{3} = 44 \text{ g}$$

6.3.2 The preparation of extraction

The operating conditions are shown in Table 5, the amount of Scots pine stem chips and hexane were measured in Table 5. Measured materials were all placed in a 500 ml flask, two boiling stones were added in the flask, and then instrument was assembled as shown in Figure 19, a circulating water flow was set through condenser, then, temperature was set at 69 °C, the boiling point of hexane. Extraction went on under different times, namely, there were two experiments, that is, for two hours and four hours. After the extraction apparatus had cooled down, the mixture was poured out and sealed. The chips after the reaction were also put in a sealed container.

Table 5 Operating conditions in the extraction process

Reaction time	2 h	4 h
Raw materials in theory (Scots pine stem chips)	44 g	44 g
Raw materials in operation (Scots pine stem chips)	44.1192 g	44.0462 g
Solvent in theory(Hexane)	200 ml	200 ml
Solvent in operation (Hexane)	203 ml	204 ml
Temperature	69 °C	69 °C

Acetone was also used to clean the flask, but acetone has a high volatility, then, attention should be paid to cleaning process, while shaking the flask, it also should deflate.

6.3.3 Determination of the mass percentages of extractives in chips

Moist content in raw materials was measured at 50 °C by moisture determination balance. And also the chips after the extraction were dried at around 35 °C in an oven for 24 h. Chips were stored after drying in the desiccator. Table 6 shows the results of drying:

Table 6 Experimental results of drying

Reaction time	The mass of chips before reaction	The mass of chips after drying	Moist content in raw materials (50 °C)
2 h	44.1192 g	30.3245 g	8.09 %
4 h	44.0462 g	31.3759 g	8.09 %

6.3.4 Pretreatment of extraction solution

The extraction solution was filtered with gravity filtration and suspended waste solids were removed in this process. The solution was used in GC analysis after filtering. The filtration equipment is shown in Figure 20.

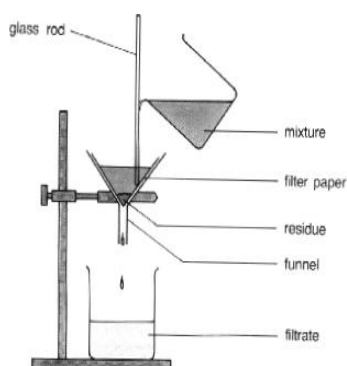

Figure 20 Gravity filtration (Christian 2003.)

6.4 The operation of GC

The operation of GC was carried out in the analytical chemistry laboratory in Saimaa University of Applied Sciences. In the Figure 21 the gas chromatography is shown in the laboratory.

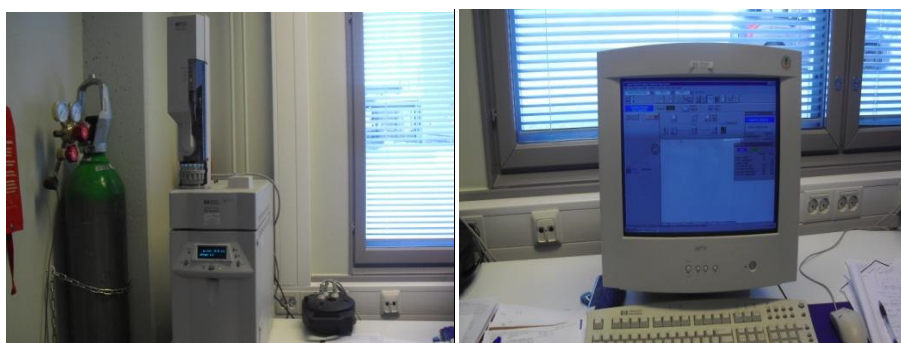

Figure 21 Diagram of gas chromatography

GC operating conditions which were used according to these measurements and Li Yuman's measurements are shown in Table 7.

Table 7 GC operating conditions

Software	Type	Split ratio	Injection volume	Column length	Injector	Detector	Oven
HP 6850 Series	Split	18.5 : 1	2 ul	30 m	300 °C	200 °C	50 – 300 °C

In fixed operating conditions in this experiment, the following are the differences between this measurements and Li Yuman's measurements: (Table 8)

Table 8 The differences between these measurements and Li Yuman's measurements

Measurer	Carrier gas	Column type	Stationary compounds	Polarity of column material
Cui Wenjuan	Helium	Varian CP – Sil 8 CB	5% diphenyl and 95% dimethyl polysiloxane	5% polar and 95% non-polar (Slightly polar)
Li Yuman	Nitrogen	Agilent HP 1	100% dimethyl polysiloxane (non-polar)	100% non-polar (Non-polar)

In these measurements two different oven ramps and run times were used, these are shown in Table 9.

Table 9 Different operating conditions in the measurements

Period	Oven ramp	Oven	Run time
Previous	10 °C/min (same with Li Yuman)	50 – 300 °C	25 min
Current	3 °C/min	50 – 300 °C	83.3 min

With the previous experimental conditions, the GC analysis of two-hour extraction

with hexane was done. With current experimental conditions, there were two GC analyse, the extraction times of which were two hours and four hours.

Experimental conditions and experiments of Li Xiaofeng were identical with these experiments, only she used a polar solvent – acetone, and in these experiments non-polar solvent – hexane was used.

6.5 Results and discussions

Some results have been gained from the GC analysis, then certain analyse should be conducted.

6.5.1 The mass percentages of extractives in chips

Moist content in raw materials should be measured at 35 °C rather than 50 °C, because drying in the oven was set at 35 °C. Only under the same operating conditions, precise results can be achieved. But, due to the limitations of the experimental conditions, the given moisture determination balance only can be set to 50 °C which is lowest.

In order to know the mass percentages of extractives in Scots pine stem chips, experimental data can be found in Table 6. From Table 6, the mass percentages of extractives in chips can be calculated, the results are shown in Table 10.

Table 10 The mass percentages of extractives in chips

Raw material	Scots pine stem chips	Scots pine stem chips
Reaction time	2 h	4 h
Solvent	Hexane	Hexane
Mass percentages of extractives	23.18 %	20.68 %

The mass percentage of extractives in chips for two hours' extraction can be calculated with following formula (2):

$$\frac{44.1192 \text{ g} - 30.3245 \text{ g} - 8.09 \% * 44.1192 \text{ g}}{44.1192 \text{ g}} * 100 \% = 23.18 \% \quad (2)$$

In theory, the mass percentage of extractives in pine is 3.5%, but the mass percentages of extractives from this experiment are far bigger than 3.5 %. Then, for this condition, it is possible that a part of hexane is contained in the mass percentages of extractives, because hexane was used as solvent, its boiling point is 69 °C, and it is volatile. When the chips were dried at 35 °C in an oven, a part of hexane also was evaporated.

The percentages of extractives in chips are 23.18 % for two hours' extraction and 20.68 % for four hours' extraction. So the amount of extractives is bigger for shorter time of extraction. For this phenomenon, it is possible that the longer extraction time is unnecessarily used, a portion of the extractives may decompose or react with other compounds during the extraction process.

6.5.2 The results and discussions of GC analysis

In GC analysis, the chromatograms can be compared with different solvent - hexane and acetone, under different time periods, and different operators.

6.5.2.1 GC analysis of the results in Cui Wenjuan's experiments

Wet samples should be dried, especially if water-immiscible solvents are used. If the extractives are to be further analyzed, low temperature - 40 °C or lower and vacuum drying should be applied. Freeze-drying is a very gentle drying method. However, some volatile components will be lost during drying operations. (Stenius 2000.) Therefore, the wet samples should be dried before extraction process. But, the pine wood was sealed to keep fresh in this thesis, it is possible that there are some peaks caused by a water-soluble substance rather than all peaks being produced from extraction with hexane.

Comparing Figure 22 and Figure 23, retention time of hexane is 5.588 min in Figure 22. However, comparing Figure 22 and Figure 24, the peak may be acetone when retention time is 5.110 min in Figure 22, because there may be remnants left in the process of cleaning instruments. But there can also be some other compounds. Figures 22 – 24 are represented in appendix 1.

In Figure 22, in addition to the above mentioned two identified peaks, the other

peaks may mostly belong to extractives. Nonpolar solvents, such as hexane, selectively extract lipophilic wood resin components, but do not always give complete extraction, which have been introduced in Chapter 6.2. Therefore, the peaks may be the peaks of lipophilic extractives. The boiling points of different chemical compounds are listed in Table 4. Highest temperature in oven was 300 °C. Different extractives have the different boiling points, and thus the chemicals with boiling points below 300 °C might be detected in GC analysis.

Figure 25 and Figure 26, broadly, show that the retention time of the Zone A and Zone C is basically the same, it is possible that the nine peaks have same substances respectively. Area B in Figure 25, has a redundant peak, with its retention time of 18.004 min. Comparing Figures 25 and 26, shows that this peak may also appear in Figure 26, however, the amount of the corresponding compound is too little. It also indicates that a portion of the extractives may decompose or react with other compounds during the extraction process when the reaction time is too long. Figures 25 – 26 are represented in appendix 2.

6.5.2.2 Comparison of the results in Cui Wenjuan’s and Li Xiaofeng’s experiments

Acetone can give complete extraction of wood resin components, but it also extracts other compounds. Nonpolar solvents, such as hexane, selectively extract lipophilic wood resin components, but do not always give complete extraction, which has been introduced in Chapter 6.2. Therefore, more extractives will be extracted with acetone, i.e. more peaks. And most of the extractives are not the same. Comparing Figures 25 and 27, some peaks with similar retention time can be found. (Table 11) These similar peaks are not necessarily the same compounds, which requires further validation.

Table 11 Similarities of the results in Cui Wenjuan’s and Li Xiaofeng’s experiments in two hours’ extraction

Measurer	Retention time (min)							
Cui Wenjuan	1.518	7.208	8.697	9.993	10.741	54.507	54.702	55.633
Li Xiaofeng	1.555	7.204	8.692	9.986	10.734	54.556	54.738	55.624

Based on Figure 25 and Figure 27, it can be seen that the extraction with acetone is relatively good. But, comparing the results in Figure 22 and Figure 29, there are more peaks in extraction with hexane. Extraction with hexane has 13 peaks, but there are only 7 peaks in the operation of extraction with acetone. In this phenomenon, it may be there is not enough retention time for sample. Figures 27 – 29 are represented in appendix 3.

6.5.2.3 Comparison of the results in Cui Wenjuan's and Li Yuman's experiments

Comparing Figure 22 and Figure 30, the total retention time is the same, but the retention time of hexane is 5.588 min in Figure 22. The retention time of hexane is 0.494 min in Figure 30. Then, in order to obtain sufficient peaks, a greater retention time is required. For that purpose, the current oven ramp was set. Current retention time of hexane in this experiment is 1.897 min in Figure 25. It is about four times larger than Li Yuman's.

Figures 30 and 31, show that the species of extractives in longer extraction time (4h) is more than the species of extractives in the operation of extraction in 2 h. For this phenomenon there are two possibilities, one might be it is true condition. Another possibility is still that the longer extraction time is unnecessarily used, a portion of the extractives may decompose or react with other compounds during the extraction process. In the experiment of Li Yuman, the amount of raw materials in 2 h was reduced by half, thus causing the species of extractives halved. However, comparing the results of Cui Wenjuan and Li Xiaofeng, it is possible that a portion of the extractives decompose or react with other compounds. Figures 30 – 31 are represented in appendix 4.

In the experiments of Li Yuman and Cui Wenjuan, the carrier gas and stationary compounds were different. The carrier gas, helium, may be more efficient and provide the best separation if flow rates are optimized. And it is known that if the carrier gas is changed, the retention time will also change. The polarity of the compounds is crucial for the choice of stationary compound, which in an optimal case would have a similar polarity as the solute. In the experiments of Cui Wenjuan, a polar 5 % diphenyl was added, which can reduce the effect of adsorption. All of these make the retention time change, then the oven ramp for getting the same retention time of the two experiments has been changed.

7 SUMMARY

The aim of this thesis was to investigate the components of extraction in pine, and compare the amounts of extractives under different times. Also, the extractants were analyzed with GC analysis, and the mass percentages of extractives were determined by drying in the oven.

The comparison of the different analysis results, shows the following points:

In this type of experiment, the moisture of raw materials needs to be dried before the experiment, to prevent some water-soluble extractives confusing the experimental results. Nonpolar solvents, such as hexane, selectively extract lipophilic wood resin components, but do not always give complete extraction. Polar solvents, such as acetone can give complete extraction of wood resin components, but it also extracts other compounds. In this thesis work, the extractives from Scots pine stem chips with hexane may be resin acids, monoterpene, sesquiterpene, triterpene and a part of fatty acids. The extraction time is not necessarily advantageous, it is possible it would make some extractives decompose or react with other compounds when the time of extraction exceeds a certain time. If the experimental results are compared, at least to ensure that the experimental conditions are the same, or only one variable changes, only in this condition can it make the results of the analysis more credible. However, in this experiment, there are a lot of variables and they do not follow the control variable method. To identify a single chemical component from the extraction solution, a more detailed analysis work should be done considering the property of the chemicals and also suitable standard solution needs to be taken as reference. For example, extractives can be identified by comparing their analyzed results of chromatograms with the library published chromatograms or with the chromatograms obtained from standard compounds, or more advanced instruments directly to mark out the name of the compounds. However, the work of identification was not carried out in this thesis work.

REFERENCES

- aBitAbout. Resin acids. <http://www.abitabout.com/Resin+acid>. Accessed on 1 Apr. 2013
- ACRF. Gas Chromatography. <http://www.gas-chromatography.net/gas-chromatography.php>. Accessed on 4 Apr. 2013
- Allen, L. H., Tappi 61(7): 47(1978)
- Assarsson, A & Åkerlund, G. 1970. Studier av vedharts – del 6. Extraktivämnessammansättning i splint- och kärnvedsprover från olika höjd i trädet
- Barnett, J. R. & Jeronimidis, G. 2003. Wood Quality and Its Biological Basis. Oxford: Blackwell Publishing Ltd
- Canadian Wood Association. Structure and Properties of Wood <http://www.paperonweb.com/wood.htm>. Accessed on 28 Mar. 2013
- Christian G.D. 2003. Analytical Chemistry , Student Solutions Manual, 6 edition, 848 pages, ISBN-10: 0471214728
- Cole, B. Extractive components of wood. <http://chemistry.umeche.maine.edu/Green/Afternoon/Cole.pdf>. Accessed on 25 Mar. 2013
- Croon, I. 1969. Hartskompendium, Svenska Pappers- och Cellulosaingenjörsföreningens hartskommitté, pp 20-21
- Dickison, W. 2000. Integrative plant anatomy. New York, NY: Academic Press. p.533
- Esau, K. 1977. Anatomy of the seed plants. 2nd ed. New York, NY: John Wiley and Sons. p.550
- Fernando, D., Hafrén, J., Gustafsson, J., Daniel, G. 2007. Micromorphology and topochemistry of extractives in Scots pine and Norway spruce thermomechanical pulps: a cytochemical approach. The Japan Wood Research Society 2007, p.134
- Gjerdrum, P. 2009. Markets for Scots pine roundwood in the north-western regions of Norway, Sweden, Finland and Scotland. Norwegian Forest & Landscape Institute, Ås, Norway

- Goodrum, J. W & Geller, D. P. 2002. Rapid thermogravimetric measurements of boiling points and vapor pressure of saturated medium- and long-chain triglycerides. Athens: University of Georgia
- Gorham, J. 1995. The Biochemistry of the Stibenoids. London: Chapman & Hall
- Harborne, J. 1998. Flavonoids, in Natural Products of Woody Plants: Chemicals Extraneous to the Lignocellulosic Cell Wall (ed. J. Rowe). Berlin: Springer-Verlag. Vol. 2, PP. 533-570
- Harris, D. C. 1999). "24. Gas Chromatography". Quantitative chemical analysis (Chapter) (Fifth ed.). W. H. Freeman and Company. pp. 675–712. ISBN 0-7167-2881-8
- Hillis, W.E. 1996. Formation of robinetin crystals in vessels of *Intsia* species. IAWA Journal. 17(4): 405–419
- Hillis, W. E. and Sumimoto, M. 1989. in Natural Products of Woody Plants I, II (J. W. Rouse, Ed.), Springer-Verlag, Heidelberg and New York
- <http://www.chemryb.at/ckurs/2007/stoff3.htm> (2011-05-24)
- INNVENTIA AB. Characterization of wood extractives. <http://www.innventia.com/Documents/Produktblad/Biorefining/Characterization%20of%20wood%20extractives%20120619.pdf?epslanguage=sv>. 25 Mar. 2013
- Kellomäki, S. 2009. Forest Resources and Sustainable Management. Book 2. Jyväskylä: Paper Engineers' Association
- Kelly, D.L. and Connolly, A. 2000. A review of the plant communities associated with Scots pine (*Pinus sylvestris* L.) in Europe, and an evaluation of putative indicator/specialist species. Invest. Agr.: Sist. Recur. For.: Fuera de Serie n.o 1-2000, 15-39
- Larson, P.R. 1994. The vascular cambium, development and structure. Berlin: Springer-Verlag. p.725
- Linde, A. G. Gas Chromatography. http://hiq.linde-gas.com/international/web/lg/spg/like35lgspg.nsf/docbyalias/anal_gaschrom. Accessed on 4 Apr. 2013

- LIPIDS. Fatty acids. <http://www.sjlipids.com/data.htm>. Accessed on 6 Apr. 2013
- Mason, W.L. and Alia, R. 2000. Current and future status Scots pine (*Pinus sylvestris* L.) forests in Europe. *Invest. Agr.: Sist. Recur. For.: Fuera de Serie* n.o 1-2000, 317-333
- Mason, W.L. 2000. Silviculture and stand dynamics in Scots pine forests in Great Britain: Implications for biodiversity. *Invest. Agr.: Sist. Recur. For.: Fuera de Serie* n.o 1-2000, 175-197
- Mutton, D. B. 1962. in *Wood Extractives and Their Significance to Pulp and Paper Industries* (W. E. Hillis, Ed.), Academic Press, New York
- Nicolov, N. and Helmisaari, H. 1992. Silvics of the circumpolar boreal forest tree species. In: *A systems analysis of the global boreal forest*, eds H. Shugart, R. Leemans and G. Bowan, 13-84. Cambridge University Press, Cambridge
- Ophardt C.E., 2003. *The chemical book*. Elmhurst College. ISBN 0-683-30242-6
- Panshin, A.J.; deZeeuw, C. 1980. *Textbook of wood technology*. 4th ed. New York: McGraw-Hill. p.722
- Pavia, D.L., Lampman, G.M. Kriz, G.S., Engel, R.G. 2006. *Introduction to Organic Laboratory Techniques* (4th Ed.). Thomson Brooks/Cole. pp. 797–817. ISBN 978-0-495-28069-9
- Prostate Miracle. Beta – Sitosterol Research. <http://www.prostate-miracle.com/beta-sitosterol.html>. Accessed on 1 Apr. 2013
- Peng, P., Bian, J and Sun, R. (2010) *Cereal Straw as a Resource for Sustainable Biomaterials and Biofuels Chemistry, Extractives, Lignins, Hemicelluloses and Cellulose*, pp. 49-72
- Raven, P.; Evert, R.; Eichhorn, S. 1999. *Biology of plants*. 6th ed. New York, NY: W.H. Freeman & Company. p.944
- Scientific Psychic. Fats, Oils, Fatty Acids, Triglycerides. <http://www.scientificpsychic.com/fitness/fattyacids1.html>. Accessed on 1 Apr. 2013
- Sheffied Hallam University. Gas Chromatography. <http://teaching.shu.ac.uk/hwb/chemistry/tutorials/chrom/gaschrm.htm>. Accessed on 5 Apr. 2013

- SLU, Inst. För virkeslära. (1999) Lagringshandbok för trädbränslen
- Stenius, P. 2000. Forest Products Chemistry. Book 3. Jyväskylä: Finnish Paper Engineers' Association
- United States Department of Agriculture. Structure of Wood. <http://www.fpl.fs.fed.us/documnts/fplrn/fplrn004.pdf>. Accessed on 6 Apr. 2013
- Wade L.G. 2003. Organic Chemistry, Prentice Hall, Upper Saddle River, New Jersey, 5th ed., p. 871
- Wålinder, M. (2000) Wetting phenomena on wood, factors influencing measurements of wood wettability
- Wiedenhoeft A.C. and Miller R. B. 2005.USDA. Forest Service, Forest Products Laboratory, Madison, WI, Structure and Function of Wood, ISBN: 9780849315886
- Wikipedia. Gas Chromatography. http://en.wikipedia.org/wiki/Gas_chromatography. Accessed on 4 Apr. 2013

APPENDIX 1

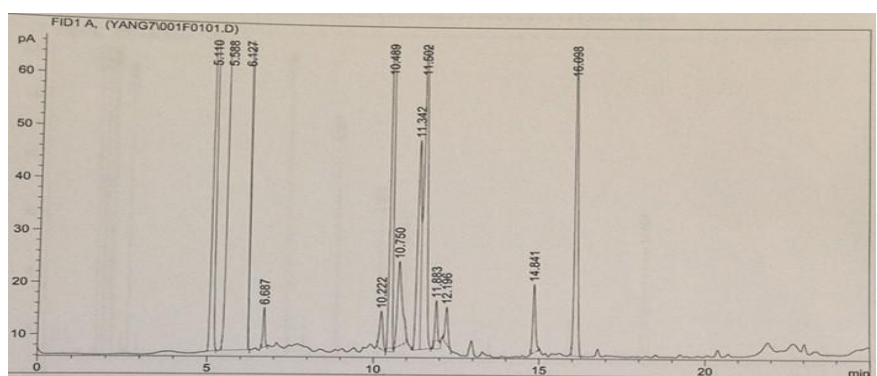

Peak #	RetTime [min]	Type	Width [min]	Area [pA*s]	Height [pA]	Area %
1	5.110	BB	0.0709	727.00555	157.37985	0.04124
2	5.588	BB S	0.1480	1.75422e6	1.41123e5	99.52013
3	6.127	BB T	0.0699	5541.57764	1177.83118	0.31438
4	6.687	BB	0.0626	31.36955	7.68140	0.00178
5	10.222	BP	0.0996	51.67848	7.30128	0.00293
6	10.489	VP	0.0747	609.28168	127.50663	0.03457
7	10.750	BB	0.1327	168.69391	16.43562	0.00957
8	11.342	PV	0.0976	288.23932	40.69812	0.01635
9	11.502	VB	0.1029	518.70337	65.83580	0.02943
10	11.883	PP	0.0791	43.32117	8.69280	0.00246
11	12.196	BP	0.0848	41.14302	7.07588	0.00233
12	14.841	BB	0.0766	71.71422	13.15534	0.00407
13	16.098	BP	0.0942	365.80453	59.13932	0.02075
Totals :				1.76268e6	1.42812e5	

Figure 22 The result of GC analysis from extraction of stem chips with hexane in 2 h (Previous) (Cui Wenjuan)

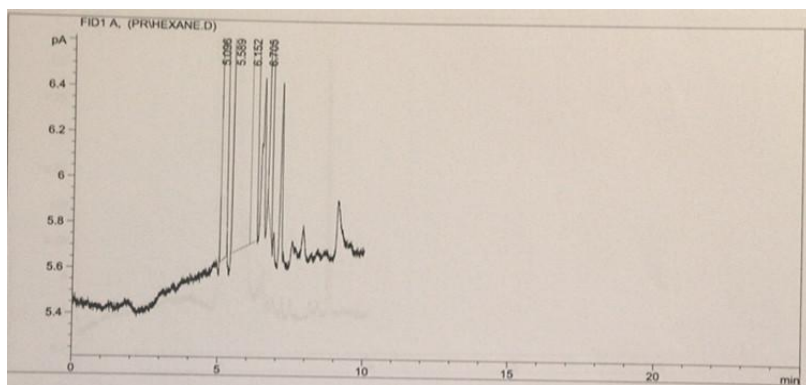

Peak #	RetTime [min]	Type	Width [min]	Area [pA*s]	Height [pA]	Area %
1	5.096	BB	0.0702	404.92664	87.14588	0.01927
2	5.589	BV S	0.1698	2.09334e6	1.48223e5	99.62096
3	6.152	VB S	0.0937	7526.19287	1338.58240	0.35817
4	6.705	BP	0.0599	33.61086	8.72646	0.00160
Totals :				2.10130e6	1.49657e5	

Figure 23 The result of GC analysis from hexane solvent (Previous) (Cui Wenjuan)

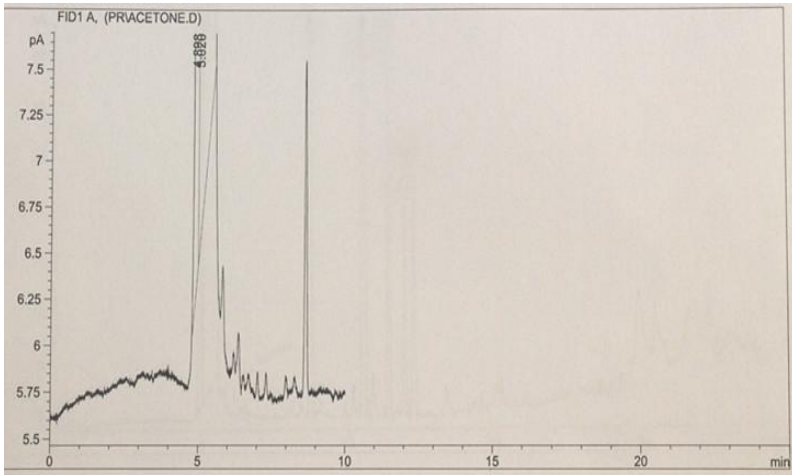

Peak #	RetTime [min]	Type	Width [min]	Area [pA*s]	Height [pA]	Area %
1	4.898	BV	0.0903	130.40718	22.93865	0.02474
2	5.020	VB S	0.1263	5.26960e5	5.06676e4	99.97526
Totals :				5.27090e5	5.06906e4	

Figure 24 The result of GC analysis from acetone solvent (Previous) (Li Xiaofeng)

APPENDIX 2

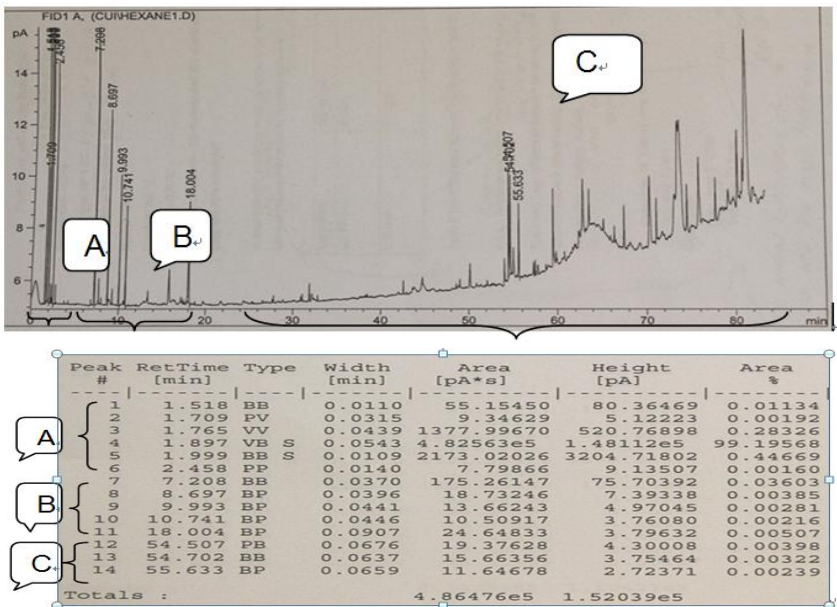

Figure 25 The result of GC analysis from extraction of stem chips with hexane in 2 h
(Current) (Cui Wenjuan)

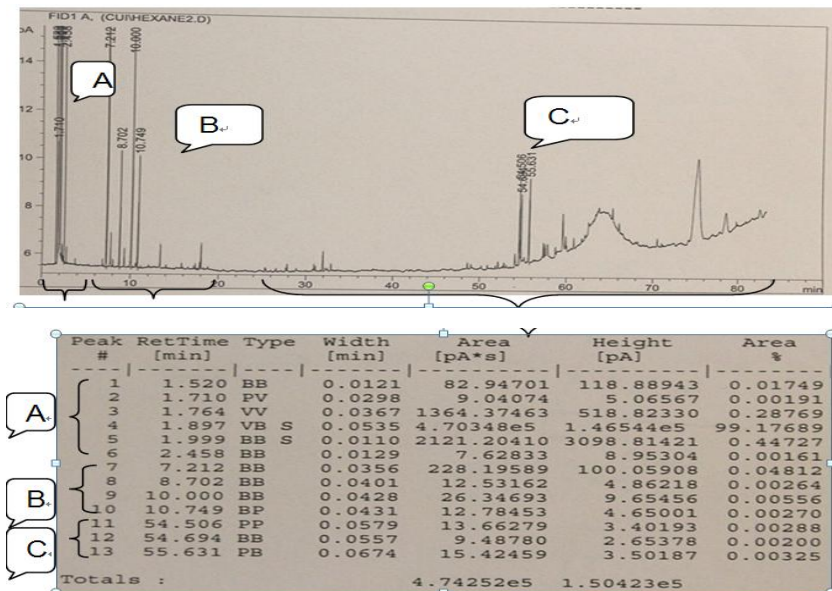
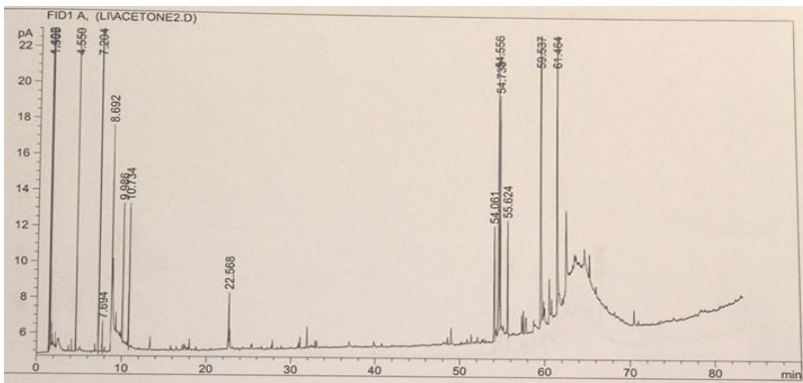

Figure 26 The result of GC analysis from extraction of stem chips with hexane in 4 h
(Current) (Cui Wenjuan)

APPENDIX 3



Peak #	RetTime [min]	Type	Width [min]	Area [pA*s]	Height [pA]	Area %
1	1.402	BB	0.0288	39.44489	23.24011	0.01966
2	1.555	PB S	0.0395	1.99665e5	9.12003e4	99.50309
3	4.550	PB	0.0261	41.92413	24.35657	0.02089
4	7.204	BB	0.0363	309.67682	132.20685	0.15433
5	7.694	BP	0.0385	4.07488	1.66566	0.00203
6	8.692	PB	0.0411	29.11343	10.90730	0.01451
7	9.986	BB	0.0417	20.61245	7.58941	0.01027
8	10.734	BP	0.0447	22.28226	7.94810	0.01110
9	22.568	PP	0.0598	11.16796	2.84427	0.00557
10	54.061	PP	0.0686	29.70702	6.23461	0.01480
11	54.556	PV	0.0712	88.37691	16.30933	0.04404
12	54.738	VB	0.0655	56.64273	13.09635	0.02823
13	55.624	BB	0.0626	27.29919	6.29030	0.01360
14	59.537	PB	0.0721	224.66135	44.36541	0.11196
15	61.464	PB	0.0767	92.13448	18.95023	0.04592
Totals :				2.00663e5	9.15163e4	

Figure 27 The result of GC analysis from extraction of stem chips with acetone in 2 h
(Current) (Li Xiaofeng)

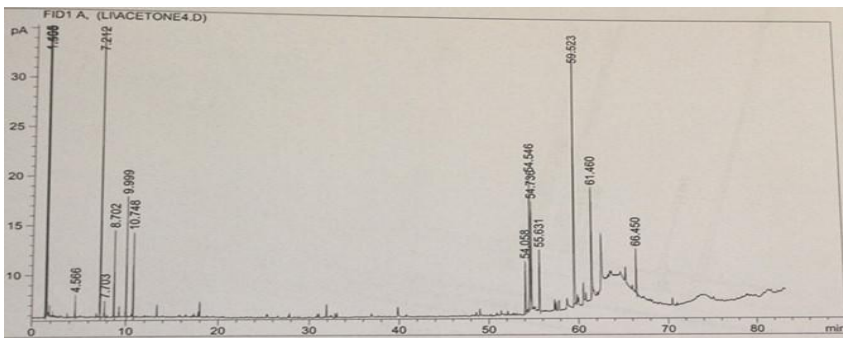

Peak #	RetTime [min]	Type	Width [min]	Area [pA*s]	Height [pA]	Area %
1	1.405	BB	0.0235	51.40376	30.81525	0.02549
2	1.558	PB S	0.0391	2.00891e5	9.33831e4	99.60394
3	4.566	PB	0.0258	3.71218	2.19205	0.00184
4	7.212	BP	0.0366	283.41565	119.93760	0.14052
5	7.703	BP	0.0375	3.90418	1.59844	0.00194
6	8.702	BP	0.0416	22.79659	8.69480	0.01130
7	9.999	BP	0.0430	33.27583	12.14396	0.01650
8	10.748	BP	0.0441	23.95634	8.44805	0.01188
9	54.058	PB	0.0598	21.99556	5.26206	0.01091
10	54.546	PV	0.0758	71.88351	14.02897	0.03564
11	54.736	VB	0.0685	47.80107	11.03917	0.02370
12	55.631	BB	0.0673	27.16873	6.17505	0.01347
13	59.523	PB	0.0702	133.50917	27.71163	0.06620
14	61.460	PB	0.0704	55.38490	11.26345	0.02746
15	66.450	BB	0.0605	18.60091	4.56489	0.00922
Totals :				2.01690e5	9.36470e4	

Figure 28 The result of GC analysis from extraction of stem chips with acetone in 4 h
(Current) (Li Xiaofeng)

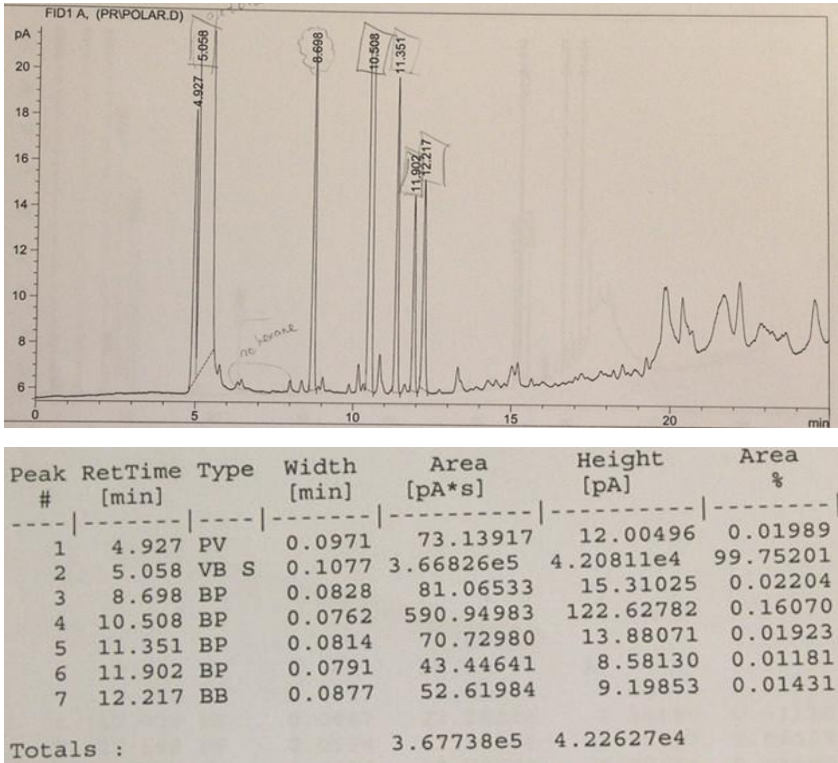
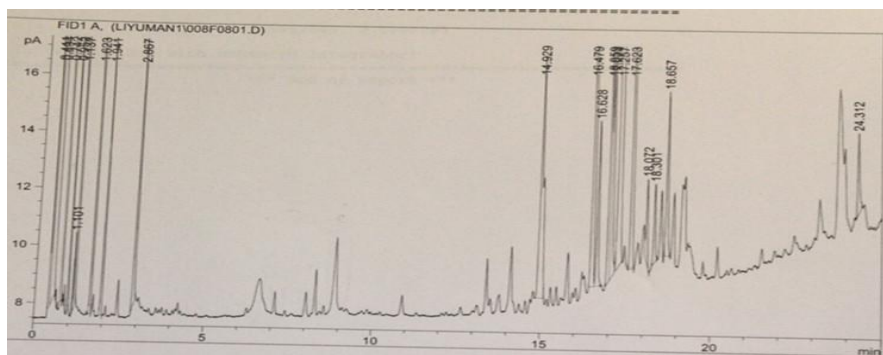

Figure 29 The result of GC analysis from extraction of stem chips with acetone in 2 h
 (Previous) (Li Xiaofeng)

APPENDIX 4



Peak #	RetTime [min]	Type	Width [min]	Area [pA*s]	Height [pA]	Area %
1	0.411	BV S	7.56e-3	1.05123e5	2.20438e5	12.23032
2	0.494	VB S	0.0180	7.50741e5	7.32226e5	87.34370
3	0.742	BB S	0.0121	2890.14575	3698.15161	0.33625
4	0.952	PB	0.0170	20.56014	18.41285	0.00239
5	1.101	PV	0.0175	2.97380	2.77858	0.00035
6	1.137	VB	0.0199	87.33470	68.24893	0.01016
7	1.623	BP	0.0268	46.40762	27.30674	0.00540
8	1.941	BP	0.0317	22.55621	11.57743	0.00262
9	2.867	PB	0.0369	32.66812	13.65080	0.00380
10	14.929	BB	0.0793	47.48916	8.47859	0.00553
11	16.479	PV	0.0553	62.61839	16.88947	0.00729
12	16.628	VB	0.0558	20.52468	5.73295	0.00239
13	16.959	PV	0.0550	32.38847	8.98770	0.00377
14	17.033	VB	0.0576	34.99759	9.16210	0.00407
15	17.257	BB	0.0570	241.75763	64.03560	0.02813
16	17.623	PP	0.0526	55.34840	16.31423	0.00644
17	18.072	BP	0.0523	9.26969	2.82230	0.00108
18	18.301	PB	0.0537	9.80087	2.73963	0.00114
19	18.657	BB	0.0540	21.58649	5.71865	0.00251
20	24.312	PB	0.0598	11.11856	2.83107	0.00129
21	25.246	PB	0.0645	11.83562	2.84696	0.00138

Figure 30 The result of GC analysis from extraction of stem chips with hexane in 2 h
(Li Yuman)

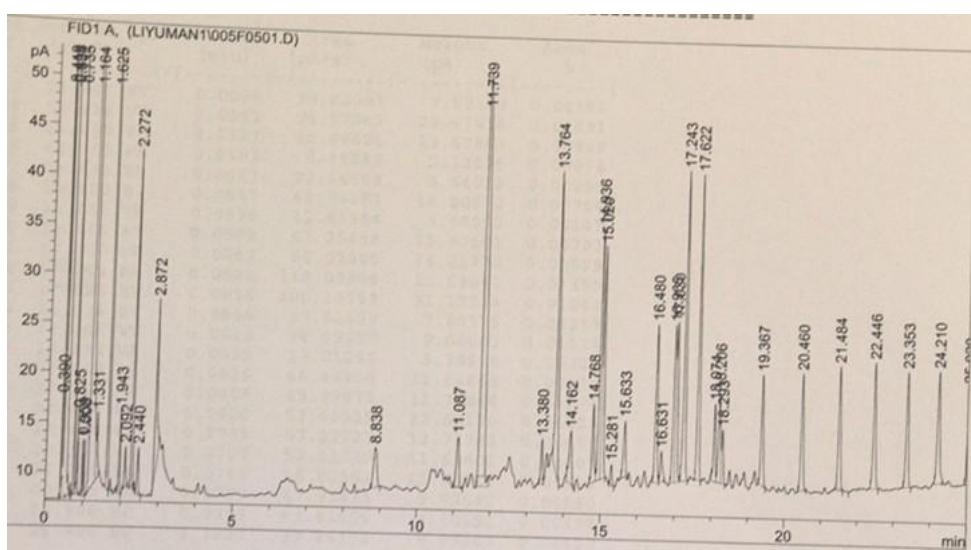

Peak #	RetTime [min]	Type	Width [min]	Area [pA*s]	Height [pA]	Area %
1	0.390	BP	6.64e-3	4.04943	10.17076	0.00046
2	0.410	VV S	8.25e-3	2.23019e4	4.50766e4	2.55851
3	0.495	VB S	0.0210	8.40618e5	6.98295e5	96.43720
4	0.534	BB T	0.0101	336.67538	554.02313	0.03862
5	0.735	PB	0.0152	93.06044	96.86733	0.01068
6	0.825	BB	0.0195	11.00204	8.26470	0.00126
7	0.959	PV	0.0185	6.51972	5.65342	0.00075
8	1.008	VB	0.0218	7.89727	5.48523	0.00091
9	1.164	BB	0.0240	6210.54932	3619.41235	0.71249
10	1.331	BB	0.0362	17.84169	6.66625	0.00205
11	1.625	BP	0.0266	193.25929	115.17997	0.02217
12	1.943	BP	0.0308	16.60172	8.48172	0.00190
13	2.092	BB	0.0380	10.40685	4.19020	0.00119
14	2.272	BP	0.0331	69.93687	33.91022	0.00802
15	2.440	PB	0.0414	12.11896	4.64575	0.00139
16	2.872	PB	0.0450	57.68931	18.20712	0.00662
17	8.838	BB	0.0895	26.57300	4.05393	0.00305
18	11.087	PP	0.0785	25.90723	5.07785	0.00297
19	11.739	PB	0.0879	301.68515	41.94430	0.03461
20	13.380	PP	0.0525	14.20062	4.30097	0.00163
21	13.764	BP	0.0596	119.34912	30.55998	0.01369
22	14.162	BP	0.0748	27.17173	5.30518	0.00312
23	14.768	BV	0.0596	30.82093	7.89350	0.00354
24	14.936	VV	0.0552	95.07262	25.67918	0.01091
25	15.020	VB	0.0527	82.69621	23.67863	0.00949
26	15.281	PB	0.0493	6.79558	2.12525	0.00078
27	15.633	BB	0.0617	22.56789	5.64013	0.00259
28	16.480	BV	0.0617	61.34253	16.00872	0.00704
29	16.631	VB	0.0596	12.81964	3.08050	0.00147
30	16.965	BV	0.0588	61.25458	15.93502	0.00703
31	17.030	VB	0.0552	60.02805	16.21379	0.00689
32	17.243	BB	0.0586	118.09636	31.63647	0.01355
33	17.622	BP	0.0526	108.36159	31.15334	0.01243
34	18.074	BV	0.0546	27.82439	7.80375	0.00319
35	18.206	VV	0.0615	36.89317	9.06583	0.00423
36	18.293	VB	0.0535	19.21296	5.39616	0.00220
37	19.367	PB	0.0636	46.44250	11.14663	0.00533
38	20.460	BB	0.0666	49.99075	11.76866	0.00574
39	21.484	BB	0.0650	53.63535	12.52130	0.00615
40	22.446	BP	0.0705	57.22737	12.72783	0.00657
41	23.353	BP	0.0707	52.53530	11.63601	0.00603
42	24.210	BB	0.0765	56.83553	11.34139	0.00652
43	25.029	BB	0.0759	47.93431	9.82652	0.00550
44	25.906	BP	0.0955	43.41559	7.18152	0.00498
45	26.986	BP	0.1237	39.86152	5.07407	0.00457
Totals :				8.71674e5	7.48249e5	

Figure 31 The result of GC analysis from extraction of stem chips with hexane in 4 h
(Li Yuman)