

ROVANIEMI UNIVERSITY OF APPLIED SCIENCES  
SCHOOL OF TECHNOLOGY

Degree Programme in Information Technology

Thesis

## **DEVELOPMENT SOLUTION FOR VMS NETWORK**

Nguyen Thuy Ha

2013

Supervisor: Maisa Mielikainen

Approved \_\_\_\_\_2013\_\_\_\_\_

The thesis can be borrowed

<b>Author</b>	Nguyen Thuy Ha	Year	2013
<b>Subject of thesis</b>	Deployment Solution of VMS Company		
<b>Number of pages</b>	54 + 6		

---

The aim of this thesis was to research the ATM and GPRS technologies in telecommunication nowadays. This thesis focused on the understanding of these techniques, the orientation and the deployment through the supposable designs.

This thesis was based on the ATM and GRPS books, documentations about network forums and the author's own experience. The results were achieved using Opnet and Edraw Max.

This thesis discussed the key issues in the ATM and GPRS technologies. They combine the documents and the market survey of a specific company to give the real data for the deployment solution in a national telecommunication network.

Key words            ATM, GPRS, and BROADBAND

# CONTENTS

<b>1 INTRODUCTION</b> .....	<b>1</b>
<b>2 RESEARCH NETWORK STRUCTURE BASED ON PACKAGE SWITCHING AND ATM NETWORK..</b>	<b>2</b>
<b>2.1 BASIC PRINCIPLE OF ATM</b> .....	<b>2</b>
2.1.1 <i>Goals of ATM</i> .....	2
2.1.2 <i>Transmission of ATM Cells</i> .....	3
2.1.3 <i>Principles of ATM</i> .....	5
2.1.4 <i>Cell Size and Payload</i> .....	6
2.1.5 <i>Principles of Network Connection in ATM</i> .....	6
<b>2.2 ATM SERVICES</b> .....	<b>9</b>
2.2.1 <i>Data Transmission in ATM Technology Application</i> .....	10
2.2.2 <i>VOD Architecture</i> .....	14
<b>2.3 BROADBAND ATM SWITCHING</b> .....	<b>17</b>
2.3.1 <i>Characteristics of Broadband ATM Switching</i> .....	17
2.3.2 <i>Standards of Switching</i> .....	20
<b>2.4 SWITCH MODELS</b> .....	<b>22</b>
2.4.1 <i>Structure of Switching</i> .....	22
2.4.2 <i>Queued Access Method (QAM) in ATM Switching</i> .....	24
<b>2.5 DEVELOPMENT NETWORK</b> .....	<b>26</b>
2.5.1 <i>Methods of Development Network</i> .....	26
2.5.2 <i>How does ATM Approach to Network?</i> .....	27
2.5.3 <i>Optical Cables in Network Penetration for Corporate Customers</i> .....	28
2.5.4 <i>Own Customers and Traffic Distribution</i> .....	30
<b>2.6 HOW TO DEVELOP ATM APPLICATION ON VMS-VMS NETWORK</b> .....	<b>32</b>
<b>3 RESEARCH AND DEPLOY DATA TRANSMISSION SERVICES WITH HIGH SPEED ON GSM</b> .....	<b>34</b>
<b>3.1 NETWORK STATUS AND THE NECESSARY INVESTMENT</b> .....	<b>34</b>
<b>3.2 LARGE-SCALE AND INVESTMENT PLANS</b> .....	<b>35</b>
3.2.1 <i>Capacity and Scope in GPRS Services</i> .....	35
3.2.2 <i>GPRS System</i> .....	35
3.2.3 <i>Upgrade GSM System</i> .....	36
<b>3.3 OVERVIEW OF GPRS ROAMING</b> .....	<b>37</b>
3.3.1 <i>Roaming Scenarios (Roaming in GPRS Network)</i> .....	39
3.3.2 <i>Home GGSN</i> .....	40
3.3.3 <i>Visited GGSN</i> .....	40
<b>3.4 ADDRESSING MODE AND ASSIGNMENT BY NAME</b> .....	<b>41</b>
3.4.1 <i>Access Point Name (APN)</i> .....	42
3.4.2 <i>Internet Protocol Address (IP Address)</i> .....	43
<b>3.5 INTER PLMN BACKBONE</b> .....	<b>45</b>
3.5.1 <i>Selections</i> .....	45
3.5.2 <i>GPRS Roaming Network</i> .....	46
<b>3.6 TECHNICAL REQUIREMENT AND TECHNOLOGY</b> .....	<b>47</b>
3.6.1 <i>SGSN</i> .....	47
3.6.2 <i>GGSN</i> .....	47
3.6.3 <i>PCU</i> .....	48
3.6.4 <i>OMC (Operations and Maintenance Centre)</i> .....	48
3.6.5 <i>Interfaces</i> .....	48
3.6.6 <i>ATM Terminal Conditions and Connection between SGSN and GGSN</i> .....	48
<b>3.7 HOW TO DEVELOP GPRS APPLICATION ON VMS-VMS NETWORK</b> .....	<b>49</b>
<b>4 CONCLUSION</b> .....	<b>50</b>
<b>BIBLIOGRAPHY</b> .....	<b>51</b>

## List of Figures

Figure 1. STM and ATM.....	5
Figure 2. Cell Structure in ATM at UNI (Nokia High Speed Access Products Inc. 2000).....	6
Figure 3. Relationship between VC, VP and Transmission Path (Turktelekom 2012).....	7
Figure 4. VP Switch and VC Switch (Cisco 2007).....	8
Figure 5. Some Models for ATM Network (Cisco 2012).....	10
Figure 6. Network Structure Using Hub, Switch and Router.....	11
Figure 7. Layer in OSI Model (Cisco 2012).....	12
Figure 8. Campus Network (Edraw Network 2013).....	13
Figure 9. ATM Switch Operations (Beizer – Shulchami 1996).....	19
Figure 10. Simple Switching Fabrics (Sobirk– Karlsson) .....	22
Figure 11. Switching and Central Buffer (Department of Computer Science 2013).....	24
Figure 12. Switching and Input Buffer (Department of Computer Science 2013).....	26
Figure 13. Switching and Output Buffer (Department of Computer Science 2013) .....	26
Figure 14. Preliminary Connection Configuration of ATM Projects.....	32
Figure 15. ATM Solution to VMS Network in Vietnam.....	33
Figure 16. PLMN network (Open IP Testing Library 2005) .....	38
Figure 17. SGSN and GGSN in Home and Visited Network.....	39
Figure 18. GPRS Roaming Exchange.....	46
Figure 19. GPRS Solution to VMS Network in Vietnam.....	49

## List of Tables

Table 1. Comparison VoIP and VoATM (Ahmed 2003) .....	2
Table 2. Components of ATM Header (Microsoft 2013a).....	4
Table 3. Types of ATM Cell (Bentall – Hobbs – Turton 1998).....	5
Table 4. ATM Network Service .....	9
Table 5. Basic Computer Network .....	10
Table 6. Competitive Advantage of VOD .....	14
Table 7. ATM Switching Characteristics .....	23
Table 8. Type of Penetration .....	31

## LIST OF ABBREVIATIONS

APN	Access Point Name
ATM	Asynchronous Transfer Mode
BG	Border Gateway
BGP-4	Border Gateway Protocol version 4
BSC	Base Station Controller
CAN	Campus Area Network
DNS	Domain Name Server
DTMF	Dual-Tone multi-frequency
EDGE	Enhanced Data rates for GSM Evolution
ETSI	European Telecommunications Standards Institute
FIFO	First-in First-out
GAN	Global Area Network
GGSN	Gateway GPRS support node
GRX	GRPS Roaming Exchange
HLR	Home Location Register
IMT	International Mobile Telecommunication
INAP	Intelligent Network Application Profile
IP	Intelligent peripheral, Internet Protocol
IPC	Information Processing Centre
ISDN	Integrated Services Digital Network
ISP	International Standardized Profile
ISUP	ISDN User Part
ITU	International Telecommunication Union
ITU-T	International Telecommunication Union – Telecommunication Standardization Bureau
LAN	Local Area Network
MAN	Metropolitan Area Network
MAP	Media Access Procedure
MMS	Multimedia Messaging Service
MPLS	Multi-Protocol Label Switching
NAT	Network Address Translation
NNI	Network to Network Interface
OMC	Operations and Maintenance Centre
PBX	Private Branch Exchange
PCU	Premises Control Unit
PDN	Public Data Network
SCCP	Signalling Connection Control Part (SS7)
SGSN	Serving GPRS Support Node
SS7	Signalling System No.7
STM	Synchronous Transmission Mode
STP	Signal Transfer Point
UMTS	Universal Mobile Telecommunications System
VDC	Volts DC
VMS	Vietnam Mobile Service Company
WAN	Wireless Area Network
WAP	Wireless Application Protocol



## 1 INTRODUCTION

Nowadays, almost telecommunication companies are established for commercial purposes indicating how to make maximum profits from telecommunication service. As a result, the competition is one of important aspects for the companies' development. Reducing input cost and increasing quality of services are considered as the best solutions at the moment. In currently economic situation, the telecommunication companies' foundation is increasing dramatically, the large companies as Vietnam Mobile Service Company (VMS) need alter techniques rapidly in order to decrease the input cost and raise competitive ability. For these reasons, the two popular telecommunication technologies Voice over Internet Protocol (VoIP) and Voice over Asynchronous Transfer Mode (VoATM) compete with each other at present. By using advantages of both capital and technique, VMS is cable of launching newer and more comprehensive techniques than the competitors' VoIP technique.

This thesis studies and develops telecommunication network based on Asynchronous Transfer Mode (ATM) technique which is still new and not popular in the world. However, it is really necessary in many technology fields nowadays such as Local Area Network (LAN), Wireless Area Network (WAN), telecommunication and terminal equipment. This fields are too wide if the author goes deeply the whole topic. That is why this thesis is limited in the research of telecommunication in VMS network including switch, ATM service, broadband and GPRS.

The thesis studies the awareness of ATM technique, the applications of ATM to network nowadays and the reasons that ATM might be a trend in future. In addition, the author also tried to solve the problem how ATM can be applied to the national level between three cities using the suggested design. The design can later be developed to be used at a global level.

Due to the limited scope of this thesis, it is impossible to include all aspects related to ATM and GPRS. Thus, this thesis only presents how ATM technique function and are developed.



## 2 RESEARCH NETWORK STRUCTURE BASED ON PACKAGE SWITCHING AND ATM NETWORK

### 2.1 Basic Principle of ATM

#### 2.1.1 Goals of ATM

Nowadays, there are many methods used in telecommunication fields. However, this thesis discusses two popular techniques at present and focused on the technique trend in future. The comparison was made between VoIP and Vo ATM technique is as shown in Table 1.

Table 1. Comparison VoIP and VoATM (Ahmed 2003)

	VoIP	VoATM
Characteristics	<ul style="list-style-type: none"> <li>- Voice over Internet Protocol</li> <li>- voice travels simultaneously over a single packet network line (fax and modem data)</li> </ul>	<ul style="list-style-type: none"> <li>- Voice over ATM</li> <li>- ATM switch carries voice traffic over an ATM network</li> </ul>
Deployment	Transmit voice over an IP network (our Internet)	A multi-service, high speed (max 1,2Gbit/s) , scalable technology
Prioritization	Employing QoS scheme	Provides many QoS(s)
Fragmentation	Data packages are divided into small fragments for fast switching	Data packages are divided into small, fixed sized, 53 byte cells
Voice compression	Low bit-rate voice compression	Voice compression is not essential
Echo Cancellation	Employs echo cancellers between the ends of the voice transmitter and receiver	Transports data, voice and video at very high speed
Header Size	IP headers are large (i.e. 20 bytes)	Only 5-byte headers

ATM is advanced packet switched systems (IFI CLAIMS Patent Services 2012), which can send simultaneously data, sound and digitize images on both LAN and WAN network. This is one of the fastest WAN connection methods nowadays. Normally, the speed reaches of 155 M bit/s to 622 M bit/s (Ad-net Technology Co. 2012). In fact, in theory it can reach higher current capacity of transmission medium. However, high-

speed means higher cost. ATM is more expensive than other techniques. ITU-T and ATM forum are the two ATM standardization organizations (Vatiainen 1999). ITU-T is about user network interface public (UNI) while ATM forum focuses on standardized UNI. In Vietnam, ATM Forum is in common use but now, it is changed to MPLS.

Asynchronous Transfer Mode (ATM) is a cell switching technology with the highlights are “high throughput, low delay and transparency of circuit switching and the bandwidth efficiency of packet-switching” (Engineering Technology & Industrial Distribution 1996). In ATM, the cells are not delivered periodically as the time slots for Synchronous Transmission Mode (STM).

According to Engineering Technology & Industrial Distribution (1996), in design ATM is used in various environment such as LAN, WAN and private network technology. Between LAN and WAN environments, the boundary can be seamlessly removed. For this reason, ATM can provide desktop to desktop multimedia networking, high bandwidth and low latency network.

In circuit switching, bit-rate services is constant such as for voice and imaging traffic while bit-rate in package switching can be variable such as for data transmission. “ATM combines both of these features and provides a technology that supports many types of network traffic-voice, data, real-time video, CD-quality audio and imaging” (Engineering Technology & Industrial Distribution 1996).

ATM is the good condition for normalization network structure and is the basic transmission with high- speed. In addition, ATM also provides many qualities of services to fulfil the different requirements about lag and damage capacity.

In conclusion, in researching the features of the ATM, people can expand an ATM system and give the messing services such as voice, packet data, video and photos. These functions can completely meet the growing demands of customers.

### 2.1.2 Transmission of ATM Cells

The ATM's primary unit are cells. The ATM technology bases on the transmission of fixed-size cells. Data is encapsulated into ATM cells that 53 bytes long-5 bytes are reserved for addressing information and the remaining 48 bytes represent the payload where data is carried. Transmitted data is divided into 48-byte lengths and packaged into these cells. Then these cells will be transmitted across the ATM network via a series of switches at station (Engineering Technology & Industrial Distribution 1996.) Every bit in each cell is conveyed on the transmission lines by left to right. According to McGraw-Hill Professional (2013), the cells are arranged on the physical transmission PDH/SDH or SONET, E1, E3 and E4 or STM of European Telecommunications Standards Institute.

At a private or public UNI, 5 bytes header of ATM is composed by six elements are showed in Table 2 (Microsoft 2013a).

Table 2. Components of ATM Header

Components of ATM header	Functions
Virtual Path Identifier (VPI)	8-bit fields; it forms part of the ATM routing address. It identifies the virtual path or which transmission line came
Virtual Channel Identifier (VCI)	16-bit fields; it identifies the virtual channel or which channel was used in upper transmission line
Generic Flow Control (GFC)	4-bit components in UNI; it negotiates multiplexing and flow control among the cells of various ATM connections
Payload Type Indicator (PTI)	3-bit components. It indicates the type of information in packaged in ATM cell sending
Reserved (RSVD)	This portion is reserved
Cell Loss Priority (CLP)	This 1-bit field defines how to drop certain cells if network congestion occurs. It is a field that holds priority values. A value of zero indicates that a cell cannot be dropped. (Engineering Technology & Industrial Distribution 1996).
Header Error Control (HEC)	1-byte; its task is detecting errors in bit coupling process and correct errors

In addition, ATM cells include 5 types of cells. They are displayed in Table 3.

Table 3. Types of ATM Cell (Bentall – Hobbs – Turton 1998)

Type of ATM cell/ Status of ATM cell	Function
Valid cell	contains useful value or repaired error cells
Invalid cell	Unrepaired error cells. Physical layer will eliminate them
Idle cell	Transmission line is cell traffic in continuous succession. In case ATM layer does not send any cell, physical layer will insert into the empty cell to have continuous cell line
Assigned cell	they included service information to service of ATM layer
Unassigned cell	cell is without service information and unused

### 2.1.3 Principles of ATM

A simple example of ATM is presented below. A work station communicates with ATM card to cut data stream into 48-byte segments. Thereafter, ATM cells are addressed by VPI, VCI and fill in the remaining fields to be 5 bytes. In the result, 53-byte cells are received from the resources: voice, video and text data. Since, these cells were generated from independent sources, conflict can occur between the time slots for the cells at ATM card of the producer. To avoid this, above three types of information assigned virtual channel as follows: VCI=1 for voice data, VCI=2 for voice, VCI=3 for video and VCI=0 for all three. This is a simple example; in fact, many VCI values are on a VPI.

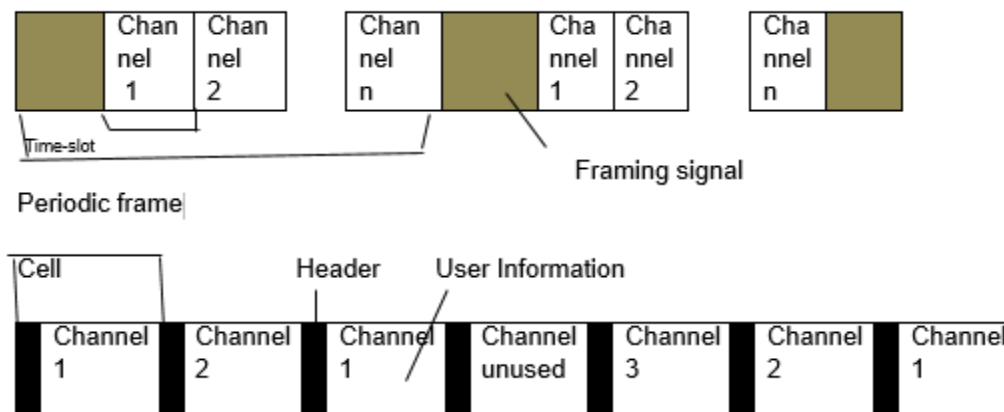
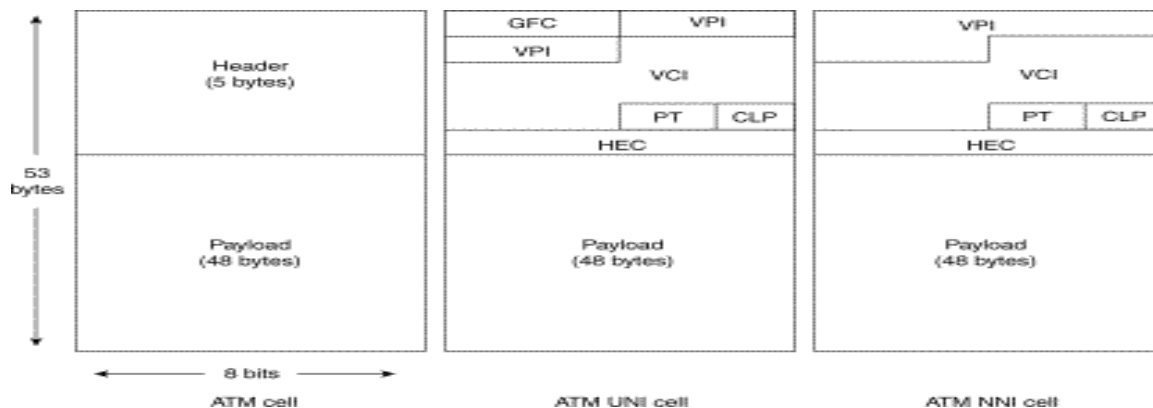

Figure 1. STM and ATM

According to Engineering Technology & Industrial Distribution (1996), “The link between two end devices is made up of one or more ATM switches. These switches are responsible for relaying ATM cells from the source to the correct destination”.

#### 2.1.4 Cell Size and Payload

The ATM Forum has much discussion about size of ATM standard cell such as choosing 32-byte load or 64-byte. 48-byte size is combination between above 2 opinions. Thus, the choice of 5-byte header is also considered between 3 bytes and 8 bytes. In the Figure 2, it describes the consideration between cell sizes, effect and time



delay when cut the cell.

Figure 2. Cell Structure in ATM at UNI (Nokia High Speed Access Products Inc. 2000)

#### 2.1.5 Principles of Network Connection in ATM

The concepts of the transmission path, virtual path (VP) and virtual channel are key issues to understanding how ATM network transfers information are showed in Figure 3 (Microsoft 2013b).

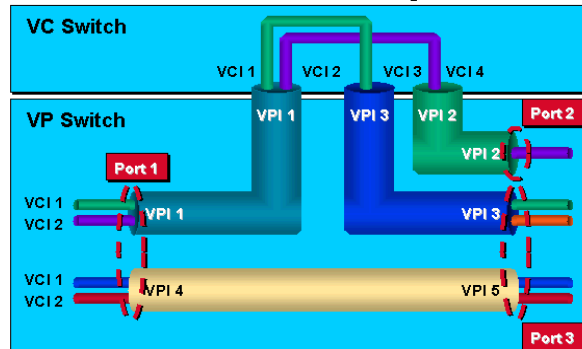

Figure 3. The Relationship between VC, VP and Transmission Path (Turktelekom 2012)

A transmission path is “path between two nodes of a network that a data communication follows” (Webopedia 2013d). A transmission path can hold multiple virtual paths while each virtual path can hold multiple virtual channels. Thus, many virtual channels can be arranged in a transmission line. Switching can be carried at transmission path level, virtual path level or virtual channel level.

The ATM system was called connection oriented transmission technique because of the reason below. A connection is made when one of the parties sends a packet to the opposite. The information of the sources about paths are saved in this packet and are switched from. The mentioned paths are called virtual paths. In case there would be a permanent connection, each connection carries a unique identity and these switches will hide this information. (Turktelekom 2012.)

When the connection is made, as the cells forming the transmission also carry the header information, the ATM switch knows from which path they would transmit the incoming cells. “The cells go through these virtual paths follow each other but it is not checked whether there is a cell loss or not” (Turktelekom 2012).

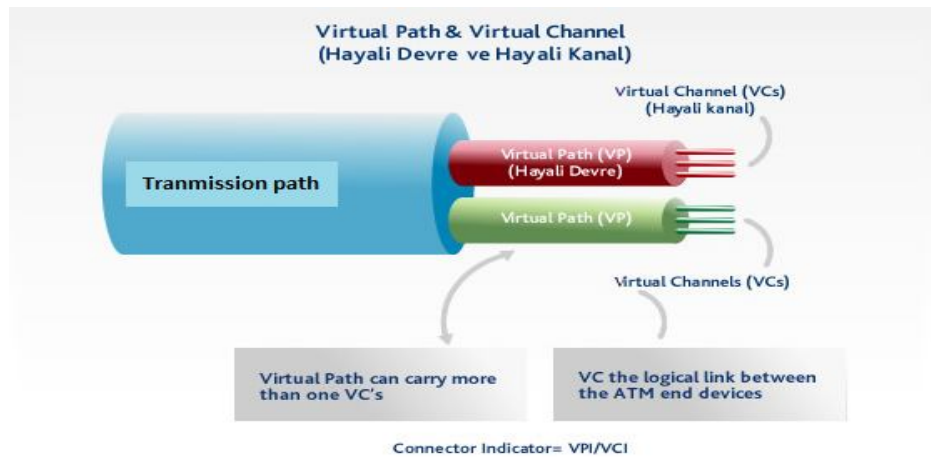

Figure 4. VP Switch and VC Switch (Cisco 2007)

The device which connects VCs together is called VC switching because it is like the telephone switching. The transmission network uses cross connect device, usually switches are divided by space. Connection equipment for VPs is called VP switch (or VP cross connection), is similar to transmission network. Not always, switching cells limit to VC switching and not always, the cross-connection machine only limit to VP switching.

Two new definitions are mentioned in this part: Virtual path connection (VPC) and Virtual channel connection (VCC). VCC is the basic unit of switching in ATM. (Grover 2003, 40). It connects two end users over the network, allow for user-network information exchange also called “control signalling” and allow for network-network information exchange for the purposes of network management and routing.

“VPC is a bundle of VCCs that have the same end point is a called virtual path connection (VPC)” (Ziegler 2004). “All the cells flowing over all the VCCs in a single VPC are switched together” (Prasad 2003, 436). In addition, grouping connections that share a common path over the network reduces control costs.

Both VPI and VCI are used to route cells via network. Each VPI and VCI must be unique for each transmission path (TP). Because of this, TP between two network

devices (example: between two ATM operators) is using VPIs and VCIs independently. When a VPI and VCI are put into each operator, it will have a VPI and VCI out.

## 2.2 ATM Services

The development of telecommunication network and Linking Broadband Communication Network can provide all services which customers require the bit-rate from few Kbit/s to up hundreds M bit/s or higher. ATM technology will be a good solution for such network. The ATM network services are the services of Broadband Communication Network showed in Table 4.

Table 4. ATM Network Service

ATM service	Definition	Example
constant bit rate	a fixed bit rate so that data is sent in a steady stream	A leased line, FAX
variable bit rate	a specified throughput capacity but data is not sent evenly	Video/tele-conferencing data, Common voice (current telephone network). Video phone or high sound quality
available bit rate	Provides a guaranteed minimum capacity but allows data to be busted at higher capacities when the network is free. (Webopedia 2013c).	High Definition Television (HDTV) or high resolution
unspecified bit rate	Does not guarantee any throughput levels. This is used for applications, such as file transfer, that can tolerate delays. (Webopedia 2013c).	File transfers

In summary, ATM technology allows to link all services in a unique network. This is a prerequisite for the development of multimedia network communication. Thread is not going deeply to encoding bit-rate and layered television model. It will focus on analysing ATM applications in data transmission.



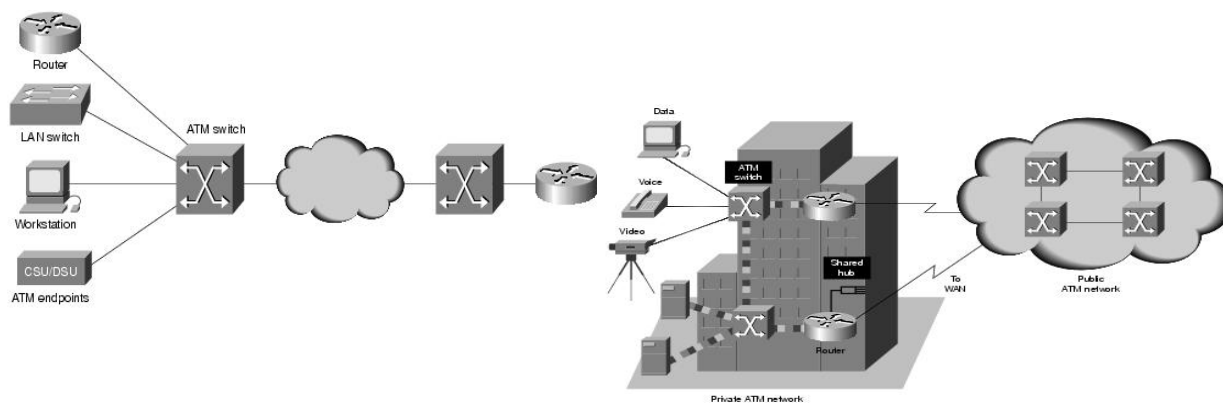

Figure 5. Some Models for ATM Network (Cisco 2012)

### 2.2.1 Data Transmission in ATM Technology Application

ATM networks have big impacts on data communication network. The common computer networks now are showed in Table 5.

Table 5. Basic Computer Network

Common network	Property
Local Area Network (LAN)	the length of about 100m allows connection of computers in a building
Campus Area Network (CAN)	the length of 1KM allows connections of computers between many buildings in a campus area
Metropolitan Area Network (MAN)	The length of 10KM, the connections of computers between campuses in a metropolitan area
Wireless Area Network (WAN)	The length of about 100KM to 1000 KM in a country area
Global Area Network (GAN)	1000 KM to 10.000KM in length. This is connections between countries

Now, LAN networks' applying from Kbit/s speed to Mbit/s and developing to G bit/s speed. ATM technology is applied in three basic elements of computer network. They are Central Office, Customer Premise Equipment (CPE) and Campus Switching.

Beside, ATM technology is also used in HUB, Router and bridge. Figure 6 shows the role of CO, CPE or CAMPUS. From the customers' place, ATM Router allows Clients and Servers communicate with each other in a virtual network. ATM local switch connects Routers into a backbone road. Workstations and Servers can be connected directly to ATM local switch to create a working group with high performance ability. The

ATM private operators as Private Branch Exchange (PBX) can also be connected to penetrate to the data and voice services.

Mobile switching center (MSC) is the backbone of ATM network, often requires a flow greater 5 G bit/s. In a switching center, it includes all ATM communication is User-Network Interface (UNI). ATM-CO switches set calls for CPE switches like the CO switches set calls for PBX.

In campus ATM Switch, these switches are smaller than the CO Switches. Although, the throughput is smaller than 5Gbit/s, they provide communication without in CO switches such as: LAN (e.g. Ethernet and Token Ring), MAN and sound. Some switches also ensure protocol conversion, LAN emulation and virtual connection.

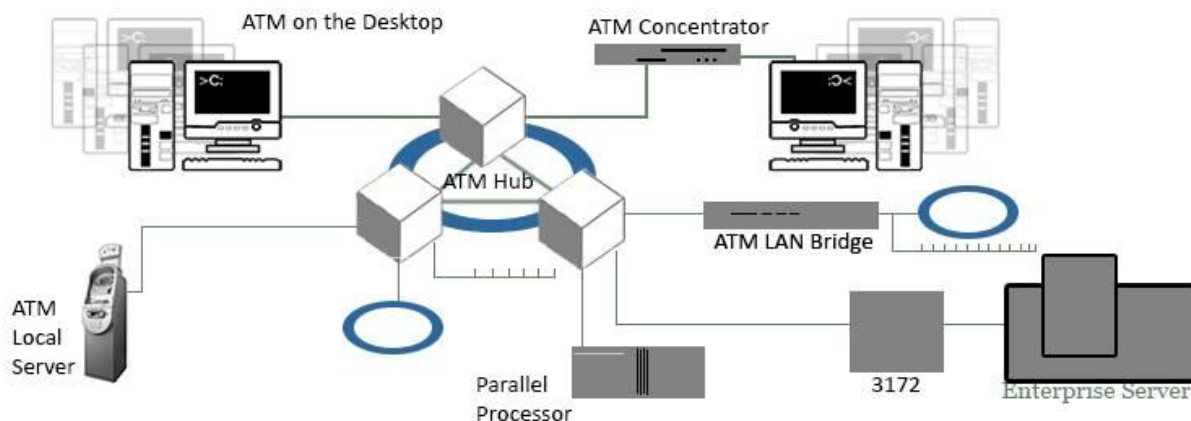

Figure 6. Network Structure Using Hub, Switch and Router

ATM Hub is the central device connecting the workstations in LAN network following star topology configuration by twisted pair (one for sending, the other for receiving). Figure 6 shows the HUB's function as the concentration of lines, segment and network management. In fact, Hub allows managers to determine the potential of the network to each user such as an Ethernet segment. HUB is usually applied in the form of decentralization to focus the user's penetration to potential share as a server or a router (Figure 6).

The Hub highest levels are usually chosen, is pillar structure built on the basic of ATM and ensure the high speed to resource as: Router or Switch. In case, a user is added, changed or displaced from a building to another, the manager can implement measures for this user.

In ATM Bridge, bridge is an intermediate system, is used to connect two LANs with the same LAN protocols. It acts as a filter address, receive packets from another LAN and switch the packets to the LAN. In addition, it does not change the content of the package and does not add to these packets. (The Computer Technology Documentation Project 2013.) The ATM Bridge works at the layer 2 of the OSI model (Figure 7).

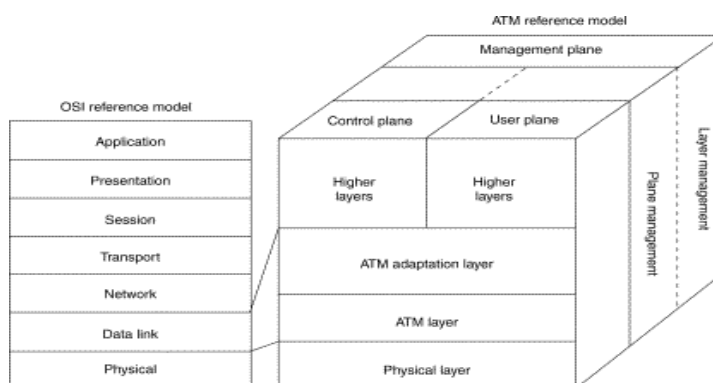

Figure 7. Layers in OSI Model (Cisco 2012)

In ATM Router, router is a device that connects two subnets which may be the similar or dissimilar. Router uses the protocols of the networks at layer 3 of OSI mode (Wikipedia 2013f). Router also handle many protocols so it can supervise carefully ATM cell chains to perform this function.

The main function of Router is detecting the address of connection equipment to router network by an interior routing protocol or an exterior routing protocol. The routed packets base on the address of destination, the source address or even the routing characteristics of terminals. Router connects different protocols through routing and protocol conversion. In addition, it also can connect to different environment (e.g.

twisted pair, Coaxial Cable, optical cable) through the transformation of the environments. Router can handle the oriented service by interconnecting or not. They usually are connected with the real or virtual circuits. Its router is quite complex. Now the producers are shifting to producing specialize circuits to increase throughput. By using some special protocols, router may detect the changes of topology configuration and correct the routing. On other hand, Router can continuously monitor the connectors of routers in a network or other networks by using a special procedure.

Model Router simulates ATM LAN, ATM Network Interface Card, Trunk card and ATM switching capabilities. In addition, ATM Router also performs both penetration and switching functions. By using penetration function, they receive many protocols and route these protocols to other gates or transform them into ATM cells. They also can route LAN package to ATM switches through Data Exchange Interface (DXI), then change XI package into ATM cells. ATM Router is also capable of switching ATM cells between the ATM interface cards.

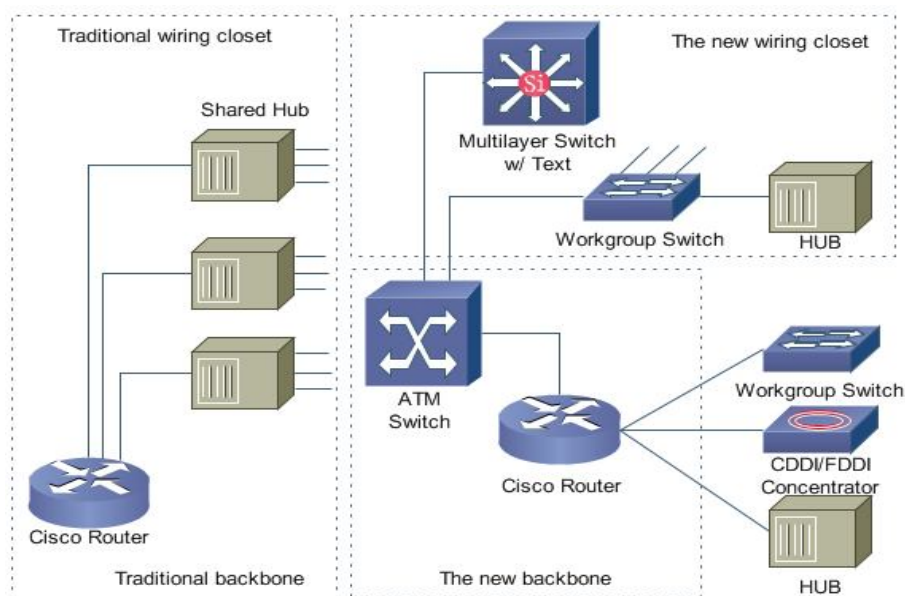

Figure 8. Campus Network (Edraw 2013)

Hub, Bridge and Router devices can active separately or be combined in the same device. While Bridge supports layers 1 and 2, Router and Hub ensure for the layers 1, 2

and 3. Gateway connects networks each other and ensures the layers one to seven are working in OSI model.

### 2.2.2 VOD Architecture

In the definition, Video on demand (VOD) or audio and video on demand (AVOD) are systems which allow users to select and watch/listen to video or audio content on demand. Internet protocol television (IPTV) technology is often used to bring video on demand to televisions and personal computers. (Wikipedia 2013a.)

Nowadays, television is communication media expanding faster than phones and PCs. One of many services is providing more TV channels in cable TV network (CATV) and users may flexibly choose television programs. In the other hand, the current technology allows telecom operators to provide video on demand services (the best flexibility allows to choose movie at appropriate time) by using competitive advantage in competitive price and video rental business. What is this competitive advantage? It is done because of applying new achievements of electronic communication technologies (Table 6).

Table 6. Competitive Advantage of VOD

Advantageous aspects	Characteristic
Hard disk capacity	Hard disk capacity grows double, prices don't change. This trend can continue in future
Compression	Using new video compression standards (MPEG); TV transmission can reach from 1.5 – 8 Mbit/s -> it's possible to storage an entire movie in a few G bytes
Signalling processing techniques	Allows transmitting from 1.5 – 8 Mbit/s within 1.5 – 5 Km of Twisted pair (ADSL)
Processing techniques and modulation	Allows transmission from 15 – 50 Mbit/s (~ TV channel), 6 MHz bandwidth in coaxial cable network or radio
Bit rate	Switching is possibly simultaneously transferred at every bit speed to customer. The different trends: transmits directly from the terminal to other terminal and transmits to penetration button. First one is more flexible (allows customers using both VOD and other service)

VOD architectures will be displayed to ensure the interactive VOD transmitted from this terminal to the other terminal. This system includes Server device, the elements of broadband switching network, the penetration operator and the customer place equipment (CPE). CPE can work in the type of compressed signal scheme and in the different requirement of bandwidth.

Firstly, Video Servers can supply almost video programs for the customers to require. The video programs can be compressed in advance (at unreal time) and stored in an external memory with random access (normally is hard disk) but in future it can be saved in semiconductor memory with suitable price. For live shows, Server can become real-time compression equipment. When users send their requirements through ATM network, the Video Server will provide a copy of video signal. At that time, video programs MPEG will be transformed into ATM cells and transmitted through ATM network. A set of server or a collection of these sets are owned by many service providers working at the same network. Besides, the network operators also can own sets of Server, then they can rent server capacity to the video operators. Also, a set of Server can own a video library storing movie systems in compression form.

ATM network ensures the connections of various elements in VOD structure. This network transmits both signaling and data program while the data is in real-time or at the required speed. It is possible to use both point-to-point and point-to-multipoint in ATM network. Furthermore, ATM networks also can carry many different services as mentioned in the previous section.

Secondly, network management function consist necessary operating systems to deploy and manage VOD network from the terminal to the other terminal. This system will contact to the various elements in network through the communications and information system model standardized suitably with Telecommunications Management Network or Smart Telecommunication Network.

About Service port and Centre Service Operator, service port keeps the communications between customers and Server via locating and connecting from a

selected service provider. Each port will manage a group of customer. As the density of customer increases, the service port can be supplied more. The service port might become a private element (intelligent network architecture) or be communicated with the elements of other network (e.g. Video server or ATM switches).

Then, Centre Service Operator allows the service providers to manage programs in a set of Servers. Moreover, it also keep the functions relating to customer groups as: charge, registration management and marketing program. Centre Service Operator can become an element of private network or communicate with the Video Server.

Next, Penetration network includes different penetration operators from ATM network to Customer Place Equipment, means the penetration multiplexer, the communication with copper wire/ coaxial cable/ fiber and network terminations (NT). The network penetration are different from fiber to point-to-point configurations or ADSL point-to-multipoint on twisted pair or the terrestrial radio or satellite.

Finally, Customer Premise Equipment (CPE) includes Set Top Boxes on devices connected to TV or video head and remote control allows users to connect to video resource and scan it to select film or other contents such as: new story, software, game or shopping online. (Wikipedia 2013g.) The main parts of the devices are: transceiver/modulator-demodulator (ADSL, fiber), block decompression (MPEG-2), communication feedback channel and the screen size. The transceiver signal comes from penetration network and can send control information back to the video server. The signals arrive to modulator or not, depend on penetration network through optical/ electric device, QAM or ADSL modulator device. Then digital signals will be come out for recovering the compressed digital video streams. This digital stream is delivered to block decompression (MPEG1 or 2) and is transformed into the same signals and display to screen. Microprocessor in Set top box is used to manage the different hardware blocks including the remote control management, then create graphical interface on the screen and exchange the protocols with port services, server and network.

## 2.3 BROADBAND ATM SWITCHING

### 2.3.1 Characteristics of Broadband ATM Switching

There are four techniques used broadband ATM switching. They are Address Division Switching, Frequency Division Multiplexing (FDM), Time-Division Multiplexing (TDM) and Space Division Multiplexing (Wikipedia 2013l).

In Address Division Multiplexing, the data is organized according to header and payload of the packages. The header brings information of address, used to decide the switching at switch node. In switching process, the translation tables implement 2 tasks. They are to translate or convert the input header value into the output header value and to determine physical destination for the data package.

Each data package at input with a corresponding header will have a new header and owns a certain time-slot at physical exit determined by translation table. Because the time-slot does not define the data packages, it leads to dispute the different packages at time-slot. Because of this reason, the data packages have to queue in buffer memory of output. In fact, the interconnection can perform three methods below. They are Point-to-Point (from header packages at an input to header packages at a corresponding output), Point-to-Multipoint (from header packages at an input to header packages at an output) and Multipoint-to-point (from header packages at many inputs to header packages at an output).

In general, the address division switching is similar in ATM switching. The ATM switching architectures are affected directly by two main factors: high-speed switching (150 M bit/s to 600 M bit/s) and statistical properties (Glover – Grant 2009, 871).

Nowadays, many telecom operators in the world offer many types of different ATM office from small to large size (from 4 to several thousand of input and output). These switches might be the public switches (normally called is ATM Central Office) or private switches (ATM LAN). Here, some typical switching architectures will be mentioned.



Each ATM switch includes two basic parts: transmission and control. The control will be researched deeply.

The transport network (TN) is defined as a physical environment which takes the responsibility for transmitting exact information from ATM input to ATM output with Quality of Services accordance in regulation. It is often the level of cell loss, cell delay, bit error rate (BER), peak-to-peak cell delay variation).

The control switching is the control part of the transport network. It determines which input will be connected to which output. The decision bases on the signaling information which switch obtains or is set by the operator on semi-permanent basic. Quality of Service in this part is often defined by call setup time and call liberation time.

In ATM switch, ATM cells are transmitted from an input (one of many inputs) to one or many outputs. This switching process may be combined with other processes such as: focus, expand, multiplexing and distribute channel for ATM traffic. The meaning of these functions is described below.

Firstly, switching is the transmission of information from an ATM logical channel at input to an ATM logical channel at output which is chose in many logical channels at output. ATM logical channel is characterized by two identifiers below. First, the physical input/output characterized by the number of physical exit. Second, a logical channel at physical is represented by Virtual Channel Identifier (VCI) or Virtual Path Identifier (VPI). (Pandey 2009.)

Both the identification of channel/path must have relations with the identification of channel/path out to guarantee the switching function. The two functions had to be installed in ATM switch. An ATM switch displays two main functions. The first function can compare with Space Division Multiplexing. The second one can compare with time-slot shift at Time-Division Multiplexing. In ATM switch system, virtual channel is identified instead of identifying the time-slot in a fixed frame. Therefore, the predetermined time-slot is no longer available. Then, many logical channels may

dispute a time-slot at the same time. For this reason, before ATM cells are given out, queuing will resolve this problem. Queuing function is one of the most important functions in ATM switching.

Secondly, in Focus Channel/ Multiplexing, ATM multiplexing in concept emphasizes the statistical integration of virtual channel in different ATMs. And focus channel is mentioned as an emphasis of reducing the number of input to a smaller value of output.

Thirdly, in Expand/ Distribute channel, the basic activity of an ATM switch is receiving a cell from a connection with a known VCI or VPI value to a connection of outgoing port (or ports) and determine the new VPI/VCI value on that connection and then retransmit the cell on other connection defined by VPI and VCI new value.

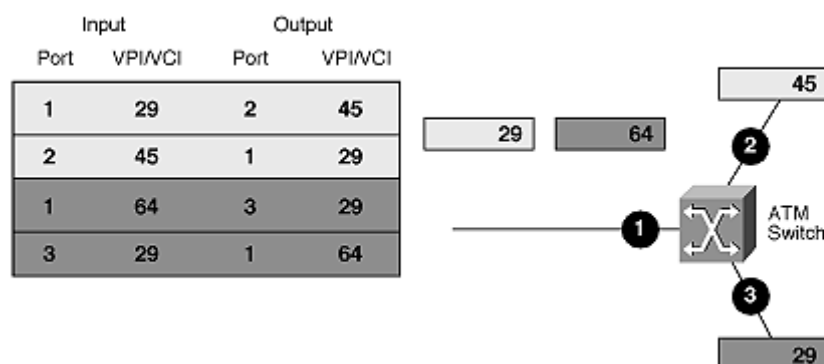

Figure 9. ATM Switch Operations (Beizer – Shulchami 1996)

In the ATM switch operation (see Figure 9), ATM cells are switched physically from an input with value  $l_i$  to an output with value  $O_j$ . At the same time, a header value  $\alpha$  at input will be translated to a heading value  $\beta$  at output.

In all the coming links and the outgoing links, the header values are unique. However, in the different ways but they may have the same heading. As in Figure 11, all the cells of the header A in the coming link  $I_1$  are transported to the outgoing link  $O_1$ . Then their header is translated into the M value. All the cells of the header A in the coming link  $I_n$  is also transported to  $O_1$  but their header receives values P. On the other hand, the easier way is explained as follows.

A number of the  $n$  coming links ( $I_1, I_2 \dots I_n$ ) transport the “ATM information to the switch, where depending on the value of the header this information is switched to an outgoing link” ( $O_1, O_2 \dots O_n$ ). A translation table are accessed by the incoming header and the incoming link number and the result of the access to the table is an outgoing link and a new header value (Dreamtech Press 2011.)

When two cells of two different coming link ( $I_1$  and  $I_n$ ) go to the ATM switch at the same time and are going to at the same port  $O_1$ , the switching cannot simultaneously give two cells at the same time. Thus, the switch must have buffer memory to save the unserved cells. This is a typical problem of ATM switching because it has to join the cells statistically. Thus, the queues must be guaranteed to store the intended ATM cells coming simultaneously at the same output. In summary, the three basic functions of an ATM switch is: routing (Space Division Multiplexing), queues and header translation.

There are two terms related to the ATM switch architecture. They are switching structure and switching system. According to Wikipedia (2013d), the switching structure is defined as follows:

Switching structure or called switching fabric, is a network topology where network nodes connect with each other via one or more network switches (particularly via crossbar switches, hence the name). Switched fabrics can offer better total throughput than broadcast networks because traffic is spread across multiple physical links.

Switching system is all means to switch ATM cells. It can be switching elements or switched fabric.

### 2.3.2 Standards of Switching

One of the standards of switching is ATM network service which is mentioned in Table 4. In the repeat, the basic standards of switching are described such as bit-rates (different bit-rate from a few K bit/s to several hundred of M bit/s), constant Bit-rate

(CBR) or Variable Bit Rate (VBR), cell loss rate, bit error rate and cell Delay Variation Tolerance, Peak-to-Peak Cell Delay Variation.

Firstly, because each different service has different committed bit rate, ATM broadband operator in future have to be able to switch a large number of information rates. These bit-rates can vary from a few K bit/s (remote control) to several hundred M bit/s (high resolution television).

Secondly, according to Wikipedia (2013b), Broadcasting is defined as follows:

In telecommunication and information theory, Broadcasting refers to a method of transferring a message to all recipients simultaneously. Broadcasting can be performed as a high level operation in a program.

Above functions are often necessary for services such as: e-mail, video library and TV program distribution. In addition, above broadcast and multi-casting can be necessary not only for several trunk lines to many subscribers but also for a number of subscribers to multi-line subscription. For example, a subscriber sends an e-mail to seven different subscribers via ATM network or a subscriber requires the service of television library at home and this subscriber is connected to network via their ATM subscriber line (subscriber loop).

Finally, the realizable ability of a STM Switch mainly is characterized by throughput, probability of blocking interconnection, bit error rate and switching delay. However, in ATM environment there are two important parameters consist: Cell Loss Rate and Peak-to Peak Cell Delay.

As in the STM switch, at the throughput of ATM switch and bit error rate are decided by technology and size of the system. By using high speed technology, the speed can reach to several hundred M bit/s with suitable bit error rate. If topology is used reasonably, the throughput can achieve higher speed.

## 2.4 Switch Models

### 2.4.1 Structure of Switching

Some switching fabrics are been working in current or future switching. Some switches are combinations between upper fabrics. Normally, a big switching fabric will be connected a smaller switching fabric to create a common bigger switching fabric. Illustrated in Figure 10 below.

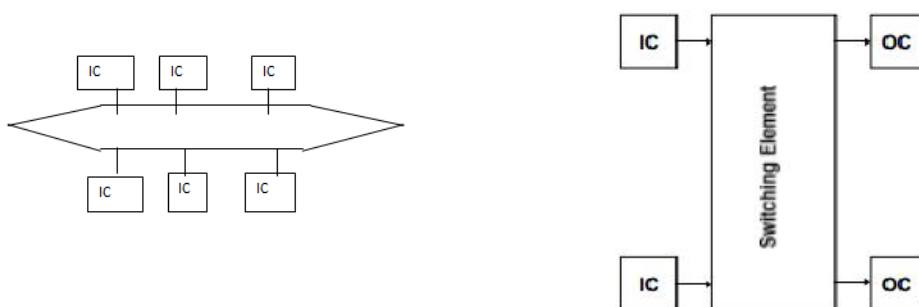

Figure 10. Simple Switching Fabrics (Sobirk – Karlsson)

The switch fabric can be partitioned as in Figure 10. It consists of the input controller (IC), the switching element and the output controller (OC). The task of IC and OC is handling the communication between the switching element and the input and output modules. According to some routing information, the switching element will route the cells from an input port to an output port. In addition, the routing is using the routing information in the cell header and the information which is stored in the node at the time of connection set-up that an association is provided by a routing table between the incoming and outgoing links for each connection, is maintained in the switching node. (Sobirk– Karlsson.)

Each fabric is described in the five aspects. They are the complexity, the speed of total maximum, the scalability, the guaranteed level of Multimedia capabilities and the block level and other attributes.

As in Figure 10, this is the simplest type of single BUS “a communication system that transfers data between components inside a computer or between computers”

(Wikipedia 2013h). Many ports are connected to a BUS. The total speed of the BUS is normally from 1 to 10 G bit/s. This structure is not complex. Because of only solving the divisions of BUS and combining buffering strategy, block level can be controlled easily. All ports generally use a common BUS so the multimedia capability can work more easily.

Switch multiple -BUS expands the definition of single BUS. It eliminates the division of BUS but increases the require control block at output. In general, each BUS works at bigger speed than Card port (from 100 to 600 M bit/s). The bandwidth is equal to switching in single BUS. For small switches, all outputs can simultaneously receive all inputs. Another method is using arbitration to ensure the output port will not get too many cells simulateously, but this demands the buffer at input and increases the complexity. This type of switching evidently has multimedia capabilities.

The switching fabric in interior self-routing is more complex such as Router Information Protocol or Open Shortest Path First. The switching does not support the multimedia so that it needs a special processing to achive this ability. If self-routing network works at the same speed with input port, the block level can be high. A boost self-routing structure usually uses the matrix to work at higher speed or use many nodes among the switching elements. Table 7 will offer the summary of the properties of mentioned above structure:

Table 7. ATM Switching Characteristics

Feature	Single BUS	Multiple BUS	Self-routing	Boost self-routing
Complexity	Low	Medium	High	High
Maximum total speed	1-10 Gbit/s	1-10 Gbit/s	1-200 Gbit/s	1-200 Gbit/s
The scalability	Difficult	Easier	Good	Best
Support point to multiple point	Good	Good	Weak	Weak
Block level	Low	Low-medium	Medium	Low

### 2.4.2 Queued Access Method (QAM) in ATM Switching

The three methods of queuing in ATM switching are center queuing, input buffers and output buffers (Department of Computer Science 2013).

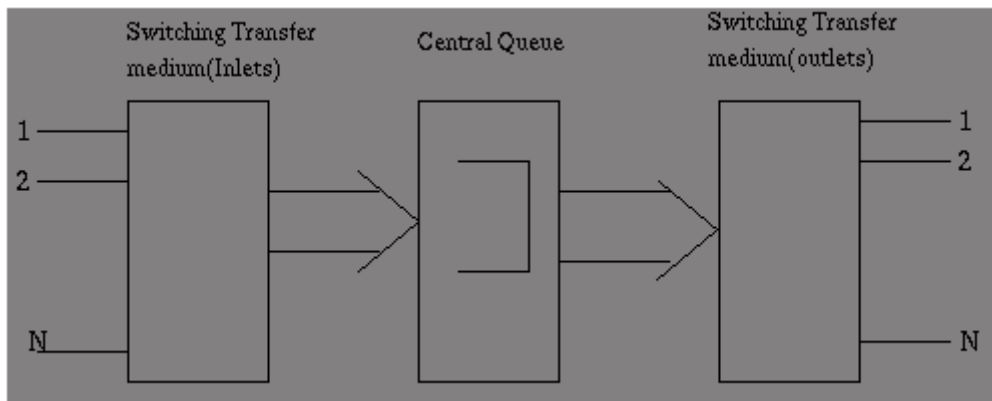

Figure 11. Switching and Central Buffer (Department of Computer Science 2013)

In this queuing method, the buffers are shared for both inputs and output. Each input cell will be saved directly in center table. Each output will choose intended cells arranged according to FIFO principle at center line. It is ensured that the output knows the intended cells. The writing and read from central memory are not simple according to FIFO principle because cells go to different receiver, they are arranged in the same row. It means that central memory is possible addressed randomly. However, logical rows have to adhere to the principle of FIFO. Because the cells can write to and read from memory at random location, a storage control part is necessary. In advantage, this method is easy to develop to large size but its disadvantage is difficult to provide different functions as: priority queues and large buffers and multilateral.

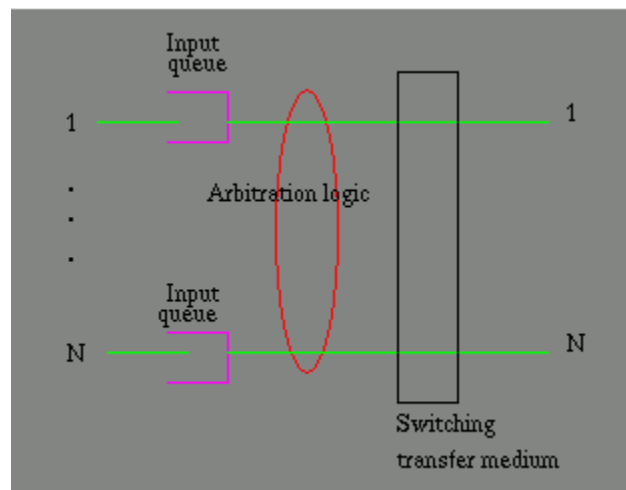
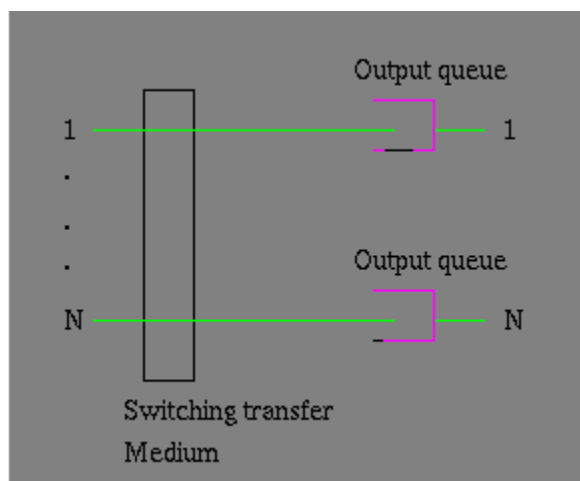

Figure 12. Switching and Input Buffer (Department of Computer Science 2013)

As to this method, the dispute of the same time slot in a port of two or more cells at input is solved at input. Each input will be equipped an own buffer to store the cells until arbitration logic possible serves this buffer. At this time, the transmission environment of switching will transmit ATM cells from the rows of input to output without internal disputes. This method is simple but the disadvantage is if Head of Line (HOL) cannot be transmit, all cells that follow it will be delayed. This phenomenon is called HOL blocking. Blocking progress is described as follows: Input cell I is given to output P; if at this time input cell J is also given to output P, it will be stopped with all the cells in the row behind it. Supposing, the second cell in the first row comes to J and is given to output Q and this output is currently free, this cell cannot be served because the first cell of the first row blocked it. Although, this method is simple but total traffic is only equal to 50-60% speed at input port. For this reason, it is not suitable with many applications and usually combined with other methods. According to Fong (2013), there are two the disadvantages of this solution below. Firstly, a complex buffering control is required to find a cell destined to an idle connection to guarantee a correct cell sequence of cells destined for the same output. Secondly, the input buffer approach achieves the worst performance in the sense of the queue length required to achieve a



given cell-loss rate in various switch loads in comparison to the other two queuing methods.



Figure 13. Switching and Output Buffer (Department of Computer Science 2013)

Output queuing switch architecture is based on the principle: the cells of different inputs intently go to the same output, is switched during a cell. However, each output can only serve one cell so to avoid the disputes, a buffer will be offered at each output of switching. Each output has its own buffer to store many cells transmitted during a cell. In principle, many cells can be given simulatingly all intended inputs to connect to an output. Switching's speed have to perform  $N$  times as great as input to not loss any cells in switching environment when it goes to output. And the system also has to be able to write  $N$  cells into row during a cell. This switching does not need arbitration logic because all cells can go to their row. The control of row bases on FIFO principle. In theory, these two methods are the most optimal methods because they achieve the highest throughput with the buffer size of the smallest cells. In fact, the ATM switches use a combination of the above queuing methods.

## **2.5 Development Network**

### **2.5.1 Methods of Development Network**

Many different strategies and plans can bring broadband ISDN service into public telecommunication network with the final purpose is developing to a global network providing all services. Putting ATM into network, a good network planning about existing services, network life and their impact on the user, is necessary. The ultimate goal of the development network is to become a good network can server all demands of customer.

The scope of time is one of important aspects. The time depends on the availability of new services, technology support, and the service products. The most important thing is the demand of service. This demand is influenced strongly by tariff policy, especially for the home customer or small business. The operator need prepare a good strategy to reduce the increasing cost for both user and operator.

In another important point, it is possible to develop different aspects in network separately. Namely, network penetration in a certain geographical area can develop

completely to intend target before the national network reaches to this target. It means all services will be performed by the ATM penetration, but narrowband services will be connected by incoming ports of ATM networks.

### 2.5.2 How does ATM Approach to Network?

The three methods let ATM broadband approach to network are substitution method, overlapping method and oasis method. It should be emphasized that each method only performs the early state of ATM process to network. The final purpose is establishing an ATM network can transmit all service domestic and foreign.

Firstly, in substitution method, it replaces all existing networks in a specific geographical area by a unique ATM network. (Cuthbert - Pitts 1993, 12). This method needs a gateway (GW) in each ATM oasis connecting to the existing network around.

Secondly, in oasis method, ATM network and broadband service are used in specified network, although other services are still on that network. With this method, the broadband services can be given to financial and trade services of cities without effecting on the existing services. Between customers in each areas, it is possible to use broadband. However, between customers of other oases, it is impossible to connect or it only connects through the existing narrowband network by gateway.

Finally, in overlapping method, broadband service provides users in entire overlapping area (entire nation) on the existing network. At this point, it can be compared with oasis method about local nature. This method provide broadband service to customers in a larger area but this can require a long access line from subscriber to switching center .

In general, oasis method is more attractive for the operators acting in liberalization environment where requires the lead in marketing while the overlapping strategies is chosen by strategically operators with "initial orientation". Geography of one region and the nature of the business are also important factors to plan a suitable deployment. In fact, people combine upper methods. For example, a network covers a nation by the

ATM cross-connect system to provide leased line services and with the ATM oasis switching, each calls will be order more when broadband services increase more.

### 2.5.3 Optical Cables in Network Penetration for Corporate Customers

One question is given here that why optical cables is used or in other words, why is optical switching. There are two replies for this question. Firstly, the transmitted bit-rates on transmission line are increasing more and more because of the development of many telecommunication services (electronic payment, office automation... Secondly, now the high speed is only be met by optical transmission systems (low cost). To further increase the system capacity, people will multiplex optically. As follows, there are three methods for providing the services (both existing service and broadband). Corresponding to each method is the development way to destination network.

Firstly, in broadband penetration separately, B-ISDN broadband services are provided to customers on the separated penetration line to ATM local exchange. There is no effect to the existing service.

The advantages of this method is giving the effect economics. As the starting price is low. In addition, profit comes early. On the other hand, it does not effect on narrowband network.

In the disadvantage in this method, between the existing services and the new service are the lowest link. Additionally, network exploitation and maintenance is not simpler. Finally, after installing, customers can desert their narrowband services and move to broadband services.

Secondly, it is multiplexing penetration. This method uses a unique penetration to customers included both narrowband and broadband information. There are two multiplexing techniques: Optical multiplexing (at the physical level) and ATM multiplexing (at the ATM layer).

In optical multiplexing method, the narrowband and broadband services will be transmitted at different wavelengths on the fiber optics of penetration line. This technique is closed to broadband penetration separately. If the multiplexing is carried at the vendors, customers can not know which type of penetration is. Otherwise, in ATM multiplexing, all services are transmitted by ATM and narrowband traffic will be separated before customers receive them. The multiplexing equipment in this case have to be suitable to transmit the narrowband service at ATM. This method is closer to the goals than optical multiplexing because it is possible to replace multiplexing equipment at terminal of switchboard by a combined connection to ATM switchboard.

In the advantages of this method, the starting price are average. In addition, the profit comes early. Additionally, network management and exploitation simplifies. On the other hand, the disadvantages of this method is when narrowband is transferred into ATM, it cause some problem of delay.

Finally, the last method is translation penetration. This method provides the most sufficient ATM equipment to customers. Both narrowband service and ATM are transmitted and the penetration to the existing network is guaranteed by the ports between these networks and ATM network. This method is developed from other method or itself.

The advantage of this method are showed below. Firstly, the network is destination network. In addition, the profit is maximum. Beside, it is the most flexible to customers. Finally, it is the most simplified in exploitation and maintenance to the penetration of customers.

There are two disadvantages in this method. Firstly, Initial cost is high because people need invest the ports to different network except ATM network and the interface between ATM equipment and not ATM equipment. Secondly, ATM network has to ensure the quality of services suitable to the existing services and high level of reliability.

#### 2.5.4 Own Customers and Traffic Distribution

For the private customer, it is the advantage of offering the new services and increasing the traffic and more profitable revenue. However, at the same time, this can cause some problem such as: how to ensure the new services with suitable cost and how to compete with the existing services. The factors encourage developing higher bit-rate service for the individual clients such as the more prosperous society, the more income increase. Additionally, the number of people using telecommute increase. The cost reduces because of technical advances. Finally, the political decision also improve telecommunication infrastructure for the individual client.

One important thing is customers will pay for services, not for network. For this reason, the services should be interesting in acceptable prices. The main component in the cost of broadband services for individual clients is cost of penetration network. Because of this, the economical solutions is one of the priority issues for the penetration network. Bandwidth is expressed in using penetration method when select they type of penetration method. The following Table 8 will show more details.

Table 8. Type of Penetration

	Bandwidth in shared use	Bandwidth in private use
Small bandwidth	Optical cable to sidewalk Passive Optical network	
Large bandwidth		Optical cable directly Logical star topology

Passive Optical Network (PON) is a point-to-multipoint, fiber to the premises network architecture. (Wikipedia 2013e). Each customer is connected to optional network through unpowered optical splitters. "PON consist of an Optical Line Terminal at the

service provider's central office and a number of optical network units near end users". (Wikipedia 2013e). A passive optical network is a form of fiber-optic access network. People can use principles of passive optical networks to delivery Broadband Optical Network services. It is more suitable for the combining of ATM broadband services when Time division Multiple Access (TDMA) method is replaced by ATM technique. This is interesting solution when ATM is used early to private clients and small business. The traffic cell 155 M bit/s or 622 M bit/s was transmitted and broadcasted from the switchboard to customer's terminal. In the opposite direction, each terminal can transmit to their cells by a suitable protocol. This process is timed so that there is only a unique traffic cell created in the back way. In the advantage of ATM protocol, although whole bandwidths still are shared for customers, bandwidth need not fixed. In defined time, customers can get more bandwidth. However, this strategy can lead to the limitation if many customers require the larger bandwidth in given time.

The most ideal method is the star topology network from customers to Remote Unit or to the local exchange. This method will provide the most bandwidth to the customers and allow penetrating to every services. The disadvantage of this method is expensive. However, the advancement of optical technology can support to this method. In this method, a logical star topology in physical tree topology can be developed from Passive Optical Network with shared waveband by supplementing wave lengths to customers who need individual waveband when these requirements are asked.

By using the existing technologies with the distance of wave length 2nm, it is possible to serve about 30 customer/ individual wavelength with both two directions to provide the penetration to the interactive services 155 M bit/s on a fiber optic tree. With the development of optical technologies, this number can reach to 60 customers.

Figure 14. Preliminary Connection Configuration of ATM Projects

## 2.6 How to Develop ATM Application on VMS-VMS Network

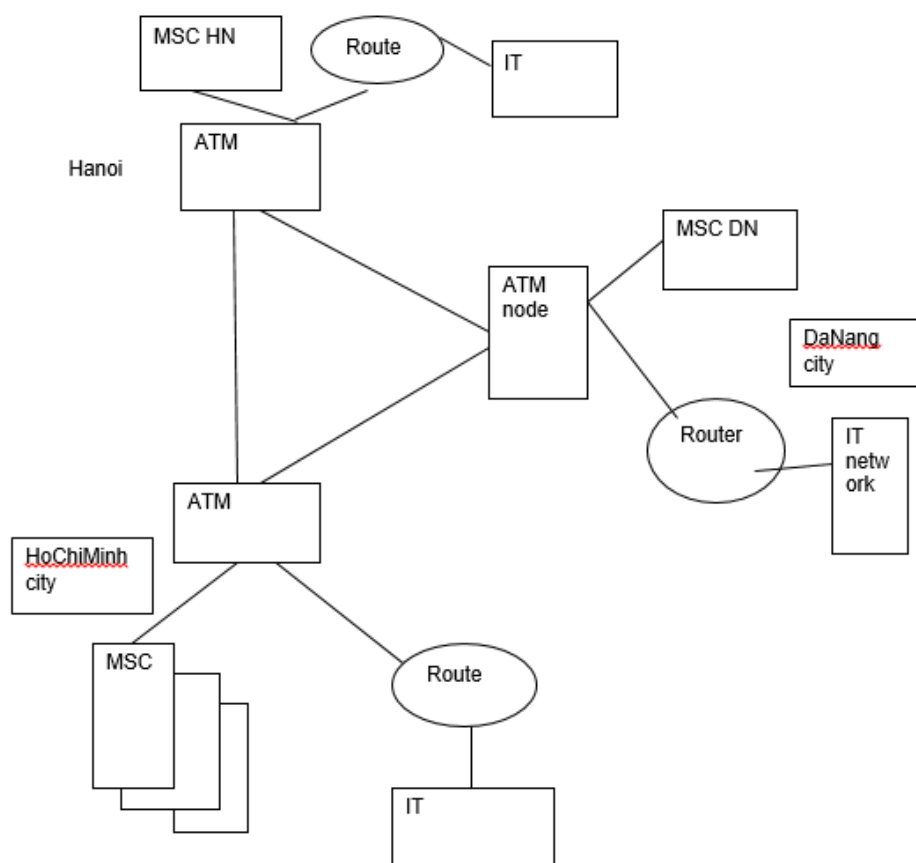
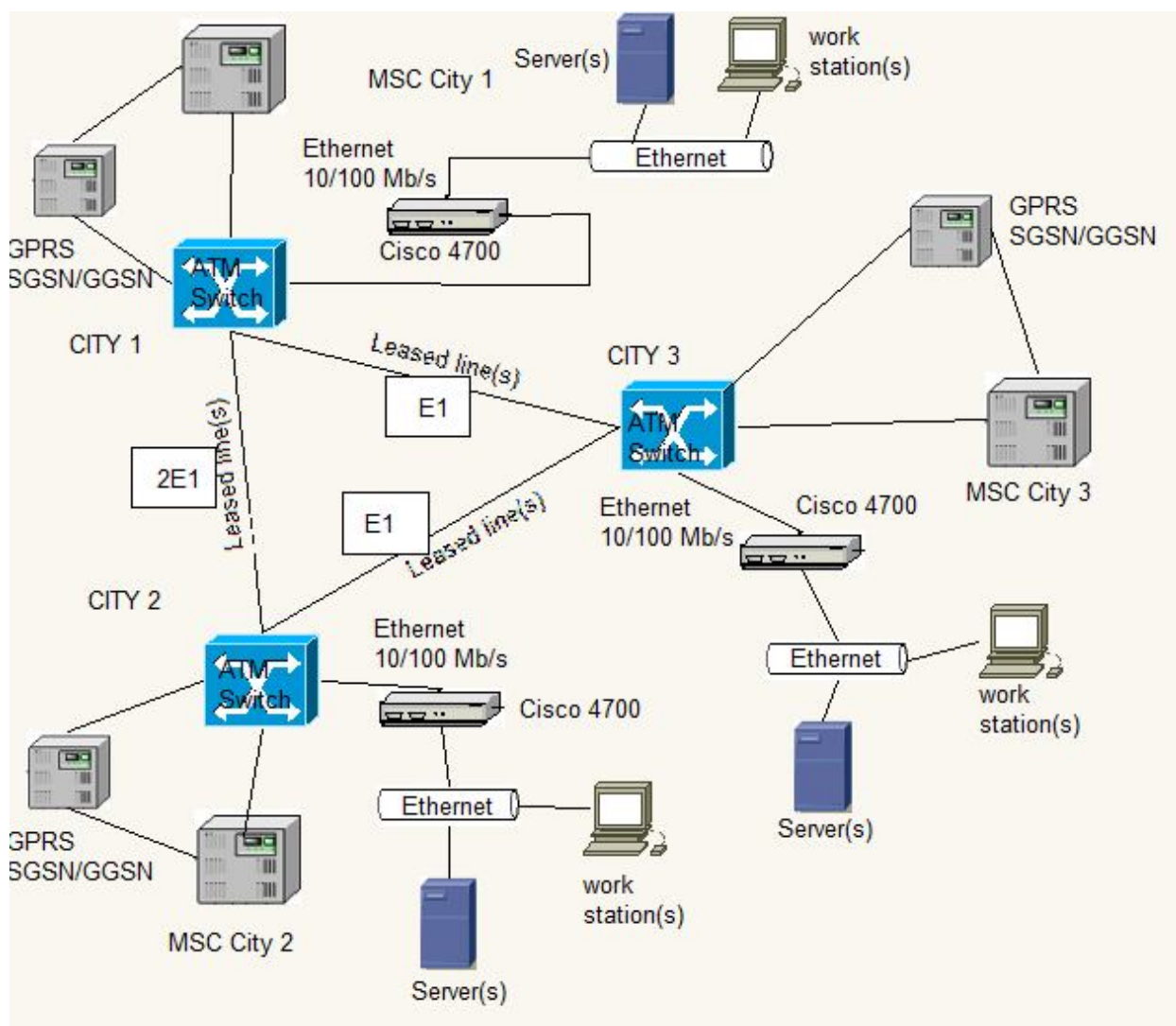

Figure 15. ATM Solution to VMS Network in Vietnam





### **3 RESEARCH AND DEPLOY DATA TRANSMISSION SERVICES WITH HIGH SPEED ON GSM**

#### **3.1 Network Status and the Necessary Investment**

VMS mobile information network was built on the base of GSM technology. It is usual improved and extended in order to meet the requirement of market and the development of technology over the world. In term of technology, GSM network completely is eligible conditions to upgrade on generation mobile communication 2.5G (GPRS/EDGE) and 3G (IMT2000) while it can still reach the maximum exploitation of available resource and utilize the maximum efficiency of invested equipment.

The investment of GPRS system is actual necessary in order to step by step deploy the third generation mobile telecommunications system. This is also the inevitable trend that the operators use to maintain the market and enhance the competitiveness. Some of the benefits of GPRS are summarized as follows.

Firstly, about reduce investment costs, the one of optimal solution in GSM network technology is capable of providing high-end data services (high speed transmission) without building new network. Through the deployment of GPRS, the service operators can upgrade their GSM system to the third generation mobile system 3G. GPRS can also coexist with GSM network; it can use maximally capacities and idle resource of existing devices in GSM network.

Secondly, about charging flexible, after deploying GPRS, the service fee of customers can base on system access time (as the traditional method of charging) or on transmitted data capability or both above methods. For this reason, the mobile services become more attractive customers, not only satisfy the customers' requirement about high speed services but also provide many packages with suitable charges. It is flexible and versatile in new service fee project GPRS supports.

Finally, about enhancing revenues and profits, while GPRS is deployed, there are some new services such as access intranet (Email/fax, access public database and personal

database), access internet (surf website, news, Ecommerce), picture television, entertainment and send message.

Through GPRS, the service operators have opened their new market in a good opportunity. For the some reason, they may enhance revenues and new profits themselves.

In the summary, on the basis of the above analysis, it is said that GPS is really necessary, is a trend and indispensable way towards 3G of the GSM mobile operators.

### **3.2 Large-scale and Investment Plans**

This part was written with the supports of the technical staff and the project and network development apartment of VMS Company. The result was based on the research of three different cities in Vietnam, called City 1, City 2 and City 3.

#### **3.2.1 Capacity and Scope in GPRS Services**

The expected capacity in designing system are City 1 with about 3,000 subscribers, City 2 with 6,000 subscribers and City 3 with 1,000 subscribers. In addition, average traffic rate of a subscriber is about 2 Kb/s. Besides, user of GPRS rate on busy time is about 10%.

#### **3.2.2 GPRS System**

SGSN is located in the center of City 1, City 2 and City 3 city. The initial target is providing GPRS service to the big cities and town. 1 gate GGSN in City 1 will connects to SGSN in City 1, City 2 and City 3. 1 charging gateway is charging GPRS service. In addition, 1 management and exploitation system is necessary. People can set the ATM transmission circuits between GGSN and SGSN nodes. As expected configuration, GGSN will be located in City 1 and connected to SGSN in the center on ATM transmission lines. To ensure data connections, the ATM transmission circuit is equipped an ATM terminal in each cities.

In addition, ATM equipment configuration requires the following demands. There are 8 console ports at E1 output and 32 console ports E1 input. The number of Ethernet 10Base-T are 6 ports and 8 ports of V35/X25. Finally, management software and monitoring transmission system are necessary.

According to Webopedia (2013a) and Webopedia (2013b), SGSN and GGSN are defined below. SGSN or Service GPRS Support Node on behalf of mobile subscribers mediates access to network resources. In addition, its task is implementing the packet scheduling policy between different QoS classes and establishing the Packet Data Protocol context with the GGSN upon activation. On the other hand, GGSN is abbreviated by gateway GPRS support node which is considered as a gateway between GPRS wireless data network and other external packet data networks (radio networks, IP networks, or private networks). Its task is provide the network access to external hosts which is wishing to communicate with mobile subscribers. Some functions of GGSN include routing, firewall and gateway/security.

Both SGSN and GGSN functions can make the charge records CDR (call drop rate). Beside, Operator and Maintenance are responsible for managing and monitoring the activities of the entire system. Finally, charging gateway's task is getting the charge records from SGSN and GGSN then, processing and collecting charges for each use case.

### 3.2.3 Upgrade GSM System

Referred to Figure 19, this is connection solution in VMS network. Firstly, the management functions for data packets on PCU network (Package Control Unit) are equipped and supplemented. Then, software for NSS and BSS is upgraded to support the connection GPRS. Finally, PCU function is supplemented to BSC. PCU is supplement function at BSC, support the packet data connections between subscribers and SGSN. The interface standard is G b.

At the first time of GPRS system deployment, it will take some times to test on both GSM900 and GSM1800 frequency range. This will help to expand GPRS services in future.

### **3.3 Overview of GPRS Roaming**

When GPRS services was given, it is expected that GPRS roaming would have run the same as GSM roaming. However, in effector process, several challenges occur and need be solved first before the roaming is made.

There are two basic roaming scenarios in GPRS roaming. People can use gateway to connect to external networks while roaming in the visited network and home network. (Wikipedia 2013i). From gateway of visited network, people can access internet network or intranet of company if that company's network is connected to the outside. However, if that network is not connected to global network, people still can connect through GPRS system of home network. For this reason, it is necessary to have IP connections between GPRS network of home network and visited network.

Two basic solutions are in GPRS roaming such as: Intra and Inter PLMN. "Intra-PLMN backbone networks connect GSNs of the same PLMN and are therefore private IP based networks of the GPRS network provider" (Bettstetter – Vögel – Eberspächer, 1999) .Intra-PLMN backbone network is a dedicated IP network only for GPRS signaling and data. The dedicated IP network is IP network which uses access control mechanisms to achieve the required level of security. Intra PLMN backbone is connected through Gp interface using Border Gateway (BG) with an Inter PLMN network. Secondly, Inter-PLMN backbone network selected by roaming requirements included BG security functionality. "Inter-PLMN backbone networks connect GSNs of different PLMNs. A roaming agreement between two GPRS network providers is necessary to install such a backbone" (Bettstetter – Vögel – Eberspächer, 1999). Normally, BG includes a firewall (network protector) and a router to support the selection of network. BG is not defined in GPRS's scope. Inter PLMN backbone is IP based network (example: private IP network or public internet network using leased line).

In the main ideal, when a GPRS operator wants to connect to roaming with other GPRS operators, they have to use their gateway to connect IP with GPRS operator outside. The GSM Association has created a guide to the backbone network. (Wikipedia 2013j). At that time, the backbone network has to use public IP address but it does not mean it is public for entire internet. In addition, the backbone network which is cross network between operators, is private network and not relative to internet network. Leased line can be used to communicate two operators while small network can communicate several operators. When the fellow traders in roaming increase, the leased line can be replaced by an international backbone network created by some IP carriers (called GRX – GPRS roaming exchange) or called GPRS mobile operator. The GRX operators was established and developed as proposed by GSM association. (Wikipedia 2013k).

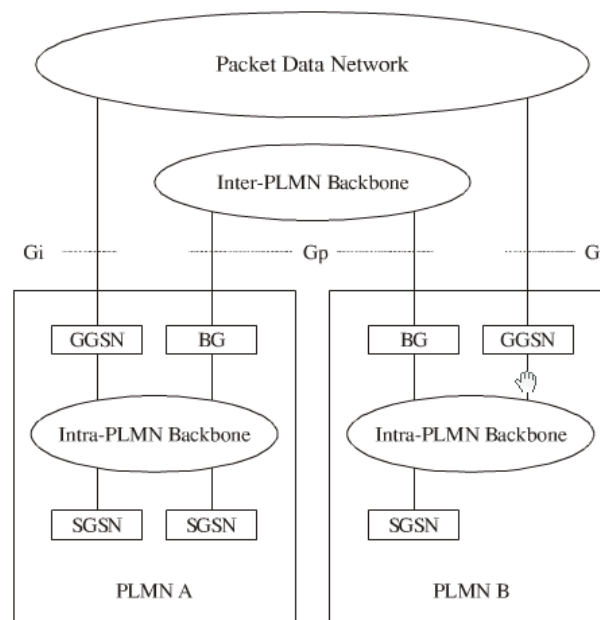

Figure 16. PLMN Network (Open IP Testing Library 2005)

IP network's structure is opener than many traditional telephones. For this reason, it can be easily attacked than the traditional telephone network. It means that the security is very important in designing network and services. For those reasons, it is necessary to equip good security systems for international backbone network to ensure safety for user when roaming GPRS is used between operators.

In GPRS network, there are many price packages. Each price of package will base on time access, sound quality, capacity of data, price of visited network to home network. It is not easy to explain to customers about high using price. For this reason, before having service agreement, the operators have to make agreement about freight issues.

### 3.3.1 Roaming Scenarios (Roaming in GPRS Network)

Roaming means that a subscriber can use network when they move to a different coverage area to their home network. (Wikipedia 2013i). This is one of successes of GSM technique. When GPRS service was performed, the users expect that the operators can deploy the roaming GPRS service well as traditional roaming GSM. However, for this purpose, the GSM/GPRS operators need some prepares when roaming GPRS such as setting up a connection IP between GPRS operators. Example is Common Channel Signal 7. In GPRS, there are two new prospects for the roaming. Firstly, this is using a gateway exchange for peripheral network such as GGSN in home network. Secondly, it is using a GGSN in visited network. In the first solution, it means that the user will be routed to home network through IP international backbone network or PLMN backbone network. In both solutions, there are strong and weak points which can be used in different purposes. Below, there are some discussions about when is suitable to use each solution.

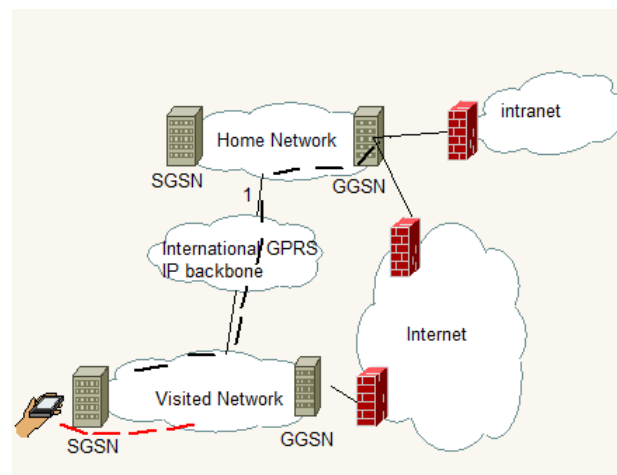

Figure 17. SGSN and GGSN in Home and Visited Network

### 3.3.2 Home GGSN

Firstly, about home GGSN, when gateway of home network is used, data traffic will always go through a port when connects GPRS to outside network. It means that there is only way to connect from GPRS network to external network. Then, GPRS network will be like a long route to connect the terminal equipment of customer to the port and go to external network. In meaning, there are no differences of connection when GGSN gateway is used. The customers can be connected to home server and home network's firewall and provided the usual services (the quality of service can be different, depends on quality of connection between GPRS operators). When users want to access Internet, Intranet or WAP, the connection is carried at GGSN gateway of home network to external network. Then, they can use the services of home network operators such as security service, WAP service ...

One of many advantages of using GGSN gateway in home network is the users need not install anything on their hand device again includes APN. However, its disadvantages has to have an IP backbone line to connect directly between home network operators and visited operators. In other hand, this helps the operators can manage the quality of services through the quality management of the backbone network.

### 3.3.3 Visited GGSN

Secondly, about visited GGSN, the most advantages of this solution is not necessary to use IP backbone network back between two networks. This means that the operators saved the rental cost of IP backbone line. Using Visited GGSN solved the optimization problem of routing and avoided the delay on transmission line when network traffic is transmitted on home network. Moreover, it also helps users easily to access and research the information in the host country such as: information about hotel, travel, weather or shopping...

However, the disadvantages are the provided services and APN users, will be different from home network operators. For this reason, users will have to install parameters again on their hand devices.

Finally, ISP roaming (Internet Service Provider) is discussed for both visited network and the peripheral network. At visited network, when accessing visited GGSN, a peripheral network can become an Intranet network of user. It is possible to use the same ISP with home network or a different ISP. Then, the peripheral network connects to internet network will require three authentication information such as: Visited ISP, Multi-homing ISP and Proxy ISP.

If the peripheral network can access internet at visited network through ISP and this ISP does not require an authentication, called visited ISP. If the ISP is also ISP of home network, called multi-homed ISP. Then it will become a gateway connecting many GPRS operators. At that time, users will be authenticate as in home network. Thus, it explained that why using Visited GGSN solved the optimization problem of routing and avoided the delay on transmission line. The final authentication is called Proxy ISP. It is similar to GSM/GPRS roaming. Home ISP will have agreement with ISPs of visited network and in fact, the authentication at home network will base on this agreement.

### **3.4 Addressing Mode and Assignment by Name**

In GPRS, the addressing mode and logical name are used in many different purposes. The addressing mode and assignment by name need the agreement of the roaming operators to avoid conflict in addressing mode. GSM and ETSI association launched some rules in which the GPRS operators must use the names and the addresses. (Wikipedia 2013j).

The addressing modes includes IP address for nodes in backbone network of intra PLMN and inter PLMN, logical name structure for nodes of GGSN, SGSN and DNS server in backbone network, and name structure of gateway for visited network.



### 3.4.1 Access Point Name (APN)

“An Access Point Name (APN) is the name of a gateway between a GPRS (or 3G) mobile network and another computer network, frequently the public Internet” (Wikipedia 2013c.)

According to Wikipedia (2103c), the data connection of a mobile device must be configured with an APN. Then it will be presented to the carrier and the carrier will then examine this identifier and its last task is determining what type of network connection should be created. An instance is “what IP addresses should be assigned to the wireless device, what security methods should be used, and how or if, it should be connected to some private customer network” (Wikipedia 2013c).

Then, according to Wikipedia (2013c) “The APN identifies the packet data network (PDN) that a mobile data user wants to communicate with”. Because the type of service is provided by the PDN, “an APN may also be used to define the type of service”. Examples of the services are connection to wireless application protocol (WAP) server and multimedia messaging service (MMS). In addition, APN is also used in 3GPP data access networks. Example are the general packet radio service (GPRS) and evolved packet core (EPC) (Wikipedia 2013c). Each GGSN consists several gateways to different visited network such as APN has to be accepted by all customers in roaming if it is at access point.

In the structure, APN was built on internet domain and can include network ID and operator ID. Network ID is commonly sent to network by terminal equipment or by users or by the installed configuration of terminal equipment. Operator ID will be added by SGSN. Users' ID show the location of gateway include the three parts base on the following structure: Mnc<MNC>.mcc<MCC>.GPRS. In that, MNC is mobile network code and MCC is the country code of the mobile. Both of them are given by IMS. The below structure is referred from Wikipedia (2013c).

<Network ID>.mnc<MNC>.mcc<MCC>.GPRS (Network ID and Operator ID)

Network ID shows the peripheral network has the domain name same to internet domain name such as: ERICSSON.COM. A GPRS operators can allow an ID of a network ended by a domain name of another operators. Example: ericsson.com.vodafone.co.uk. It becomes complex to customers using the optimal routing and visited GGSN to access intranet. They also can use local gateway to optimize the routing and increase effectively. In one more example of Multi-homed ISP, if there is only one domain name of peripheral network used, the customers can select a network ID in all GPRS network. For this reason, the access to internal gateway will not need change the name configuration of APN in the terminal equipment.

The service access point name (SAPN) has to be considered, in case, ID of network includes only one source address. If the user roams to a network are supported by an APN, a visited GGSN will be used in replacement. And if domestic network does not provide the translator of Service access point name, the user will not be able to use them. For example, the SAP can be carried through the internet access or WAP access.

### 3.4.2 Internet Protocol Address (IP Address)

In GPRS, IP address must be assigned in all nodes of backbone network such as GGSN, SGSN, DNS, etc...as well as the terminal equipment. In backbone network, GSM association and internet policy maker unified to give a general strategy for public IP and the policy must be accepted by internet user community.

There are two types of address: public IP address and private IP address. The addressing mode and assignment by name perform the authority on all available address on internet. It consists IP address which will be allocated by Internet Corporation for Assigned name and number (ICCAN). Internet Assigned Numbers Authority (IANA) will show the available address to the regional internet register such as RIPE, ARIN (American Registry internet numbers) as well as Asia-Pacific Network Information Centre (APNIC). Public address creates the spaces in internet network and they are used freely. (Verio 2013.) The main purpose of assigning address is allowing transmitting the information from the terminal to other through internet. Internet network

only recognizes public IP addresses and only can route public addresses. The second purpose is allowing the information which can connect to private intranet. A part of the source address will be used by network without connecting to public internet network. The addresses in this scope can be used by any people in this network and there is no combination between this network and internet network. When these addresses are used freely, they depend on users to ensure that they are unique to current network which they are using. In case, private address requires to connect the peripheral network, there is one device called Network Address Translator (NAT) used in connecting networks together. There is one map of NAT and several separate address towards public network and it will carry the conversion address of resource and destination for the packets go through.

About IP address for GPRS or inter PLMN backbone network, the GSM associate decide that public address need be used for GPRS is national IP backbone network. There are some causes for this decision. Firstly, it ensures the uniqueness of all address which have been using. Secondly, it ensures the consistency of the address if the standards of roaming are established among IP backbone in the future.

In case, an operator need use private address in internal backbone network, they still have to send their public address to the fellow traders in roaming. For that purpose, network address translation (NAT) is used in BG to transmit internal private address into public address. However, NAT met the difficult requirements. NAT has to understand General Telemetry Processor (GTP) message including IP address of SGSN and GGSN to convert the addresses. In addition, the requirement of domain name server (DNS) will come from the both sides: internal and external node.

In GPRS, each terminal equipment will have an IP address which can contact together, called IP terminal address. The address can be assigned dynamically or statically. Because of the lack of public IP address, static address could not be used even when dynamic address are used, the number of public address is not enough. It means that the most users will use private address and GPRS operators will use NAT and PROXY. How to solve this problem? It depends on each operators and the better solution is, the

better services are. In most cases of roaming, the user can use IP address of the operator. In the future, when the number of GPRS and UMTS terminal equipment increases, the quality of service will be more perfect. In addition, the requirement of raising IP address will make GSM associate take a lot of efforts to ensure that the deployment service of 3G will not be slow because of the lack of IP address.

### **3.5 Inter PLMN Backbone**

As above described, when using GPRS roaming and connecting to GGSN of home network, it obligates to access an IP connection between the operators. This network is quite new to GSM network and then is used widely as SS7 nowadays.

International GPRS backbone network will become a complex IP network although it only perform a special function for GPRS roaming service. This demands that the IP operators will have to new preparations. To save money for building from the beginning, Inter-PLMN backbone network can be handled and built on the basic of connection network between two or three operators. In the lately term, because of the requirement of market, GSM association developed the build of Inter-PLMN backbone network. For this reason, many GPRS operators have been communicated together.

#### **3.5.1 Selections**

Basically, there are two connection abilities between the internet operators such as direct connection among GPRS operators and the establishment of a roaming network in GPRS.

The first solution is considered as a temporary method in connecting IP between the operators. However, for the lately term, the roaming GPRS network will be period. The direct connection might be used at the first time when the number of connection is small. However, when the number of connection increases, the direct connection is not suitable anymore. Then, the operators can use the following connections: through public IP network (security is implemented strictly confidential because this solution will

connect to peripheral network), through leased line (FR, ATM or IP/PPP) or virtual private network as a secondary service on the leased line.

### 3.5.2 GPRS Roaming Network

International GSM association proposed the establishment of international backbone network of GPRS. This network is similar to international telephone network today. Some international operators take responsibilities of transmission to their customer (GPRS operators) and simultaneously joint the transmission between the operators. For this reason, a customer can communicate to the customer in other operators. The operators make an agreement about providing the services for customers and other operators. It means that GPRS operators need only sign the contract with the service provider of transmission connection and the providers will agree each other and the IP operators is called GRX (GPRS Roaming exchange). (Kuisma 2013). Backbone network will take responsibility about transmitting all traffics through BPG-4 protocols. For this reason, firewall systems with international BG are necessary to block unnecessary information (information from the operators without an agreement) and connect to peripheral network.

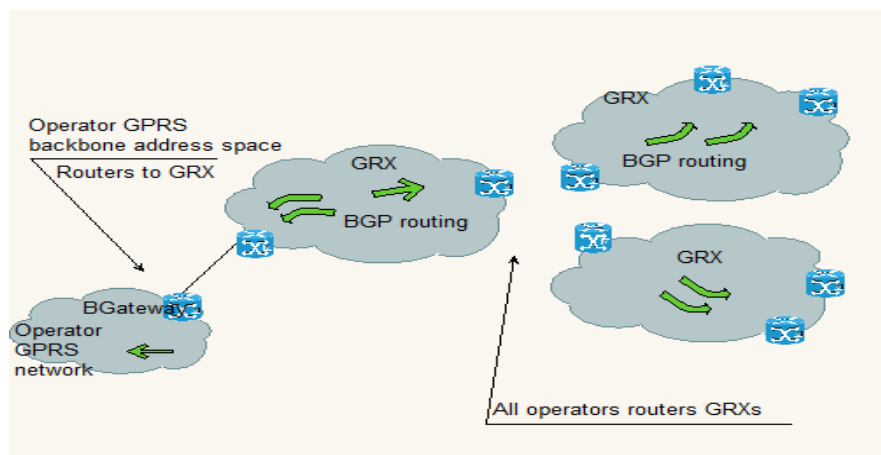

Figure 18: GPRS Roaming Exchange

There are two advantages of the GRX solution. Firstly, a GPRS operator need not create a connection to each roaming operators. Instead of it, the operators can only connect to GRX and can perform GPRS roaming service to other operators. Secondly,

a GPRS operators can choose the low connection with low capacity. However, the requirement of quality and capacity line can be upgraded to a higher level. That will help the GPRS operators using effectively the connection to GRX because the cost of renting the connection line to foreign is not cheap.

### **3.6 Technical Requirement and Technology**

#### **3.6.1 SGSN**

Compliance with GSM recommendation 03.60, the following functions have to be supported by SGSN:

- attach/detach and mobility management
- search and call GPRS subscribers
- update Home Location Register (HLR) ...
- transfer management between SGSN(s)

Functional safety and security against unauthorized access is in SGSN. Moreover, SGSN has to have authentication for subscribers. In addition, the interface connects to SMS systems and allows subscribers to send and receive message. The exchange between SGSN and MS has to follow GSM recommendation. Connect signal between SGSN and HLR/MSC/VLR are established on MAP V3 interface.

Besides, the subscription status has to be managed on the SGSN. When it is idle status, the subscribers do not connect to GPRS. SGSN need not update the data of the subscribers and subscribers are considered idle. Subscriber data in standby mode if it is connection status or Standby and the last one is ready status meant to exchange information on GPRS.

#### **3.6.2 GGSN**

GGSN has to be supported the following functions such as package data connection, maintenance and fault tolerance and configuration management. Besides, it must have

the ability of security management. The management of system resources and data bind sessions are necessary. Finally, this is the management of charge record.

### 3.6.3 PCU

PCU is additional function for BSC to connect to SGSN. PCU will be equipped by SBC providers, in particular is ERICSSON at the Southern, Central and Alcatel at the North. The elements are supported as buffer size and the compatibility when EDGE is deployed.

### 3.6.4 OMC (Operations and Maintenance Centre)

In the operations and maintenance centre, the techniques are required the graphical interface with the user. In addition, it is necessary to equip the warning and maintenance management. Retention time alerts in minimum 7 days. Lastly, it is configuration management system.

### 3.6.5 Interfaces

About the interfaces, it requires the ability of complying the recommendation of ETSI about GPRS interface. Besides, it has to connect physically IP interface on E1 and Ethernet 10/100 Mbps. At last, it must allow to define up to 150,000 ways in Internet routing table.

### 3.6.6 ATM Terminal Conditions and Connection between SGSN and GGSN

An equipment becomes an ATM terminal when it met the below requirements. The device has to comply the GSM standards outlined in the recommendation of ETSI/GSM Technical Specification. Besides, the devices, functional elements of the system must operate under the relevant ITU standards. In addition, the compatibility and connectivity to telecommunication network system and GSM is very important. The device should be compactible and meet the technique and services of GPRS and EDGE.

Nowadays, the 3G technique is growing strongly. For this reason, the requirement of compatibility with the development of the third generation mobile phone are necessary.

Besides, it also has to ensure the compatible with IMT 2000 interface when connecting to ATM switches of mobile phone network. In the other hand, ATM transmission need a monitoring and management system is characterized below. It must be compatible with ITU standard about management network. X11R5 allows integration with the existing management network. It servers management and operating in focus. In addition, it must allow up to 255 concurrent sessions access via LAN / WAN. Beside, ATM terminal requires the other conditions such as: computer network connector, X 25 network, frame relay, DTMF signalling , at least 6 ports connected Ethernet 10/100 Base T, Ethernet over ATM and the transparent channels.

### 3.7 How to Develop GPRS Application on VMS-VMS Network

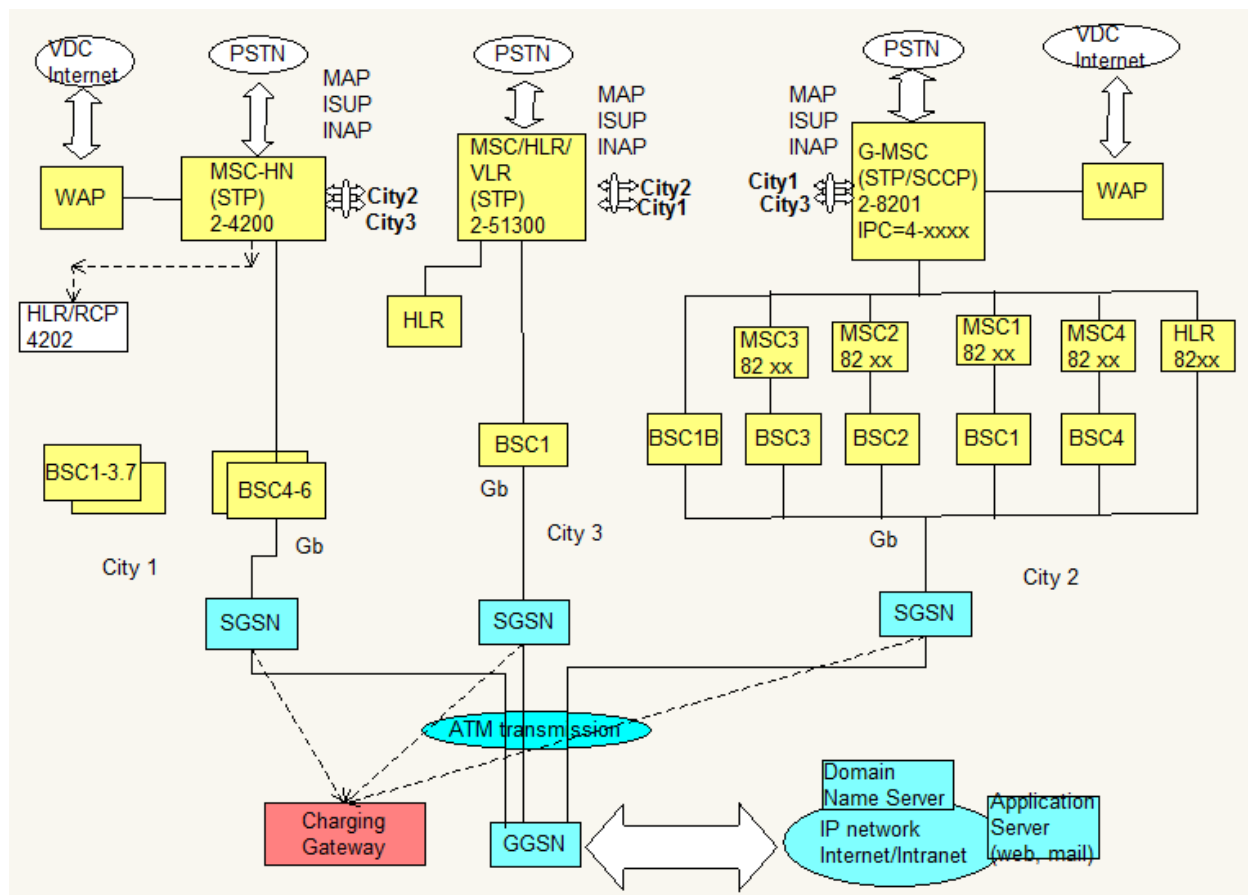

Figure 19. GPRS Solution to VMS Network in Vietnam



#### **4 CONCLUSION**

Nowadays, the requirement of broadband and high speed service increase gradually when the media services are satisfied. Additionally, the appearance of new technology fields is one of reasons to introduce and develop ATM technology. In global scale, the researches of ATM technology have reached ITU standards and ensured the unity in the development process of ATM technology. The ATM development proved that ATM system is preeminent and confident in many countries.

So far, ATM technology has been deployed in operation in Vietnam. This inevitable progress marks a new development in the telecommunication industry in Vietnam. Through the research of ATM development in a specific network, the thesis supports readers to give an overview of the development trend of telecommunication in future.

With the author's knowledge, experience and research, the thesis is result of the progression in the last five months. The research is the basic knowledge to develop the technique in many applications over ATM. This thesis answered what ATM is, how ATM approaches to network nowadays and why ATM might be a trend in future. Moreover, using supposable and feasible designs solved network's development problem in national scale. Based on these basic steps, the application of ATM in LAN, WAN network or terminal equipment can be researched in future.

**BIBLIOGRAPHY**

- AD-net Technology Co. 2012. Address: <http://www.ad-net.com.tw/index.php?id=237>. Accessed 30 August 2013.
- Ahmed, F. 2003. A Comparison of Voice Technologies (VoIP, VoFR, and VoATM). Address: <http://www.developer.com/voice/article.php/3112781/A-Comparison-of-Voice-Technologies-VoIP-VoFR-and-VoATM.htm>. Accessed 31 August 2013.
- Beizer, A. – Shulchami, A. 1996. ATM. Address: <http://telem.openu.ac.il/students/courses/c20398/atmproj/home.htm>. Accessed 7 July 2013.
- Bentall, M. – Hobbs, C. – Turton, B. 1998. ATM and Internet Protocol, 34. Great Britain: Arnold, a member of the Hodder Headline Group.
- Bettstetter, C. – Vögel, H.J. – Eberspächer, J. 1999. GSM Phase 2+ General Packet Radio Service GPRS: Architecture, Protocols, and Air Interface. IEEE Communications. Address: [http://albin.abo.fi/user/jfors/saker/AdvTel%20tenta/GSM%20Phase%202+%20General%20Packet%20Radio%20Service%20GPRS\\_%20Architecture,%20Protocols,%20and%20Air%20Interface.pdf](http://albin.abo.fi/user/jfors/saker/AdvTel%20tenta/GSM%20Phase%202+%20General%20Packet%20Radio%20Service%20GPRS_%20Architecture,%20Protocols,%20and%20Air%20Interface.pdf). Accessed 25 August 2013.
- Cisco 2007. Configuring VP Tunnels and VP Switching. Address: [http://www.cisco.com/en/US/tech/tk39/tk797/technologies\\_configuration\\_example09186a0080128b08.shtml](http://www.cisco.com/en/US/tech/tk39/tk797/technologies_configuration_example09186a0080128b08.shtml). Accessed 17 June 2013.
- Cisco 2012. Asynchronous Transfer Mode Switching. Address: [http://docwiki.cisco.com/wiki/Asynchronous\\_Transfer\\_Mode\\_Switching](http://docwiki.cisco.com/wiki/Asynchronous_Transfer_Mode_Switching). Accessed 15 June 2013.
- Cuthbert, L.G – Pitts, J.M. 1993. Internetworking in Broadband Networks, 12. Switzerland: IOS Press.
- Department of Computer Science 2013. ATM switching. Address: <http://cs.gmu.edu/cne/modules/atm/ATMswitch.html>. Accessed 29 July 2013.
- Dreamtech Press 2011. ATM: The WAN Protocol. Address: Dreamtech Press / EG\_ACN\_03\_Sign\_Off\_T1\_Fixed\_Tsoff. Accessed 18 August 2013.

- Edraw 2013. Campus Network Design Software. Address:  
<http://www.edrawsoft.com/Campus-Network.php>. Accessed 28 September 2013.
- Engineering Technology & Industrial Distribution 1996. ATM networking. BICSI LAN Design Manual. Address:  
<http://etidweb.tamu.edu/cdrom3/CHAPTR11.PDF>. Accessed 23 June 2013.
- Fong, L.S. 2013. ATM (Asynchronous Transfer Mode) Switching. Address:  
[https://www.google.fi/url?sa=t&rct=j&q=&esrc=s&source=web&cd=6&cad=rja&ved=0CGwQFjAF&url=http%3A%2F%2Fweb.fsktm.um.edu.my%2F~nazlita%2Fwret2104\\_6\\_ATMswitching.ppt&ei=-OBCUoaYDKfy4QSR44GIBg&usq=AFQjCNGGzhpUQkR4CFPnNdJ4DZ3AIDBoIQ&sig2=LloJYLMx6v5J2MfPyPtGHw&bvm=bv.53077864,d.bGE](https://www.google.fi/url?sa=t&rct=j&q=&esrc=s&source=web&cd=6&cad=rja&ved=0CGwQFjAF&url=http%3A%2F%2Fweb.fsktm.um.edu.my%2F~nazlita%2Fwret2104_6_ATMswitching.ppt&ei=-OBCUoaYDKfy4QSR44GIBg&usq=AFQjCNGGzhpUQkR4CFPnNdJ4DZ3AIDBoIQ&sig2=LloJYLMx6v5J2MfPyPtGHw&bvm=bv.53077864,d.bGE). Accessed 25 September 2013.
- Glover, I.A – Grant, D.P. 2009. Prentice Hall, 871. England.
- Grover, W.D. 2003. Mesh-based Survivable Transport Networks: Options and Strategies for Optical, MPLS, SONET and ATM Networking, 40. New York: Prentice Hall PTR.
- IFI CLAIMS Patent Services 2012. Packet switching system. Address:  
<http://www.google.fi/patents/US4827473?dq=Packet+Switched+Systems#forward-citations>. Accessed 27 August 2013.
- Kuisma, J. 2013. Pricing Mechanisms for GPRS. Address:  
<http://www.netlab.tkk.fi/opetus/s38042/k03/topics/pricingmechanismsforGPRSroamingslides.pdf>. Accessed 23 August 2013.
- McGraw-Hill Professional 2013. Transmission Network Fundamentals. Address:  
[http://www.mhprofessional.com/downloads/products/0071701222/0071701222\\_chap01.pdf](http://www.mhprofessional.com/downloads/products/0071701222/0071701222_chap01.pdf). Accessed 14 September 2013.
- Microsoft 2013a. ATM Cell Structure. Address: <http://technet.microsoft.com/en-us/library/cc976978.aspx>. Accessed 27 August 2013.
- 2013b. Virtual Paths and Virtual Channels. Address: <http://technet.microsoft.com/en-us/library/cc978149.aspx>. Accessed 17 June 2013.
- Nokia High Speed Access Products Inc. 2000. Transmission of ATM cells. Address:  
<http://www.google.com/patents/US6081530>. Accessed 13 June 2013.
- Open IP Testing Library 2005. GSM. Address:  
<http://www.ipt.etsi.org/iptlib/iptLib/BaseDocs/3GPP23.060.htm>. Accessed 23 June 2013.

- Pandey, S. 2009. Introduction to ATM Switching. Address:  
[http://www.oocities.org/sha211\\_211/atmswitch.html](http://www.oocities.org/sha211_211/atmswitch.html). Accessed 29 July 2013.
- Prasad, K.V.K.K. 2003. Principles of Digital Communication System & Computer Network, 436. 2<sup>nd</sup> edition. New Delhi.
- Sobirk, D. – Karlsson, J.M. ATM Switching Structures – A Performance Comparison. Address:  
<http://ece.ut.ac.ir/classpages/F83/Advanced%20Computer%20Networks/PAPERS/SWITCH/NTS12.PDF>. Accessed 2 July 2013.
- The Computer Technology Documentation Project 2013. Network Design. Address:  
<http://www.comptechdoc.org/independent/networking/cert/netdevices.html>. Accessed 13 July 2013.
- Turktelekom 2012. ATM. Address:  
<http://www.turktelekom.com.tr/tt/portal/CorporateProduct/Small-and-Medium-Business/Data-and-Broadband-Services/Point-to-Point-Access-Services/ATM-SMB/description>. Accessed 15 July 2013.
- Vatlainen, H. 1999. ATM - Asynchronous Transfer Mode. Address:  
<http://www.atm.tut.fi/faster/mpoa/dippa-www/node6.html>. Accessed 2 September 2013.
- Verio 2013. What is the difference between public and private IP addresses?. Address:  
<http://supportcenter.verio.com/KB/questions.php?questionid=655>. Accessed 18 September 2013.
- Webopedia 2013a. SGSN. Motorola Worldwide. Address:  
<http://www.webopedia.com/TERM/S/SGSN.html>. Accessed 30 August 2013.
- 2013b. GGSN. Address: <http://www.webopedia.com/TERM/G/GGSN.html>. Accessed 29 August 2013.
- 2013c. ATM. Address: <http://www.webopedia.com/TERM/A/ATM.html>. Accessed 28 September 2013.
- 2013d. Transmission Path. Address:  
[http://www.webopedia.com/TERM/T/transmission\\_path.html](http://www.webopedia.com/TERM/T/transmission_path.html). Accessed 17 August 2013.
- Wikipedia 2013a. Video on Demand. Address:  
[http://en.wikipedia.org/wiki/Video\\_on\\_demand](http://en.wikipedia.org/wiki/Video_on_demand). Accessed 25 July 2013.
- 2013b. Broadcasting. Address: <http://en.wikipedia.org/wiki/Broadcast>. Accessed June 28 2013.

- 2013c. Access Point Name. Address:  
[http://en.wikipedia.org/wiki/Access\\_Point\\_Name](http://en.wikipedia.org/wiki/Access_Point_Name). Accessed 4 August 2013.
  - 2013d. Switched fabric. Address: [http://en.wikipedia.org/wiki/Switched\\_fabric](http://en.wikipedia.org/wiki/Switched_fabric). Accessed 28 July 2013.
  - 2013e. Passive optical network. Address:  
[http://en.wikipedia.org/wiki/Passive\\_optical\\_network](http://en.wikipedia.org/wiki/Passive_optical_network). Accessed 8 August 2013.
  - 2013f. OSI Model. Address:  
[http://en.wikipedia.org/wiki/OSI\\_model#Layer\\_3:\\_network\\_layer](http://en.wikipedia.org/wiki/OSI_model#Layer_3:_network_layer). Accessed 24 August 2013.
  - 2013g. Customer-premises equipment. Address:  
[http://en.wikipedia.org/wiki/Customer\\_premise\\_equipment](http://en.wikipedia.org/wiki/Customer_premise_equipment). Accessed 17 September 2013.
  - 2013h. Bus ( computing). Address: [http://en.wikipedia.org/wiki/Bus\\_\(computing\)](http://en.wikipedia.org/wiki/Bus_(computing)). Accessed 18 August 2013.
  - 2013i. Roaming. Address:  
[http://en.wikipedia.org/wiki/Roaming#Home\\_and\\_visited\\_networks](http://en.wikipedia.org/wiki/Roaming#Home_and_visited_networks). Accessed 29 August 2013.
  - 2013j. GSM Association. Address: [http://en.wikipedia.org/wiki/GSM\\_Association](http://en.wikipedia.org/wiki/GSM_Association). Accessed 15 September 2013.
  - 2013k. IP exchange. Address: [http://en.wikipedia.org/wiki/IP\\_exchange](http://en.wikipedia.org/wiki/IP_exchange). Accessed 17 September 2013.
  - 2013l. Multiplexing. Address: <http://en.wikipedia.org/wiki/Multiplexing>. Accessed 27 September 2013
- Ziegler, C. 2004. Asynchronous Transfer mode (ATM) Network. Address:  
<http://www.sci.brooklyn.cuny.edu/~ziegler/CIS49.2/ATM.pdf>. Accessed 16 June 2013.