

Saimaa University of Applied Sciences
Technology Lappeenranta
Double Degree Program in Civil and Construction Engineering

Liubov Bakaeva

Barrier free main entrance arrangement in the renovation of residential house in Saint-Petersburg

Thesis 2017

Abstract

Liubov Bakaeva

Barrier free main entrance arrangement in the renovation of residential house in Saint-Petersburg, 24 pages, 7 appendices

Saimaa University of Applied Sciences

Technology, Lappeenranta

Double Degree Program in Civil and Construction Engineering

Thesis 2017

Instructor: Lecturer Martti Muinonen, Saimaa University of Applied Sciences

The aim of this work was to observe regulations connected with renovation of public buildings, understand how demands of reduced mobility persons affect to the architectural concepts. And to design a project of real reconstruction according to standards.

The information was gathered from literature and the Internet. Measurements of the existing structure were executed with an electronic measurement device. For the development of drawings, AutoCAD® software was used for automated 2D. For 3D design and calculating of materials Revit, software for Building Information Modeling, was used. For budget calculations the estimation analytical complex "A0" was used.

The final drawings and information about the project are represented in the appendices. As the result a construction decision was provided to the company Complex Engineering design.

Keywords: barrier-free environment, persons with reduced mobility, renovation

Table of contents

1	Introduction	5
1.1	Background	5
1.2	Common information about target building.....	6
1.3	Terminology	8
2	Legislation, instructions and basic concepts	9
2.1	Legislation in Russia	9
2.2	Legislation in Finland.....	10
2.3	Legislations and programmes in Europe	10
2.4	Elements of the entrance in the building accessed for persons with disabilities 11	
2.5	Common elements of barrier-free environment.....	13
3	Renovated entrance solution.....	14
3.1	Inspection of structures	14
3.2	Structural solutions.....	15
3.2.1	Safety fencing and preparation of the building site.	15
3.2.2	Demolition works	16
3.2.3	Formworks.....	16
3.2.4	Setting up the frame of reinforcing.....	16
3.2.5	Concreting	17
3.2.6	Draining	17
3.3	Architectural concept.....	18
3.4	Budget estimations.....	19
4	Summary.....	21
	Figures	23
	Tables	23
	References	24

Appendices

Appendix 1 Photo fixation of existing situation

Appendix 2 Measurements of the facade

Appendix 3 Plan of topographical survey S 1:500

Appendix 4 Structural scheme

Appendix 5 Architectural concept

Appendix 6 Materials list

Appendix 7 Local cost estimate

1 Introduction

1.1 Background

Everyone knows that people are the most valuable resource on the planet. And caring for the sick and disabled is the moral duty of society and each of its members.

Adaptation of disabled people begins at the stage of accessibility of public places, the opportunity to physically use the benefits of society. Such access to public places begins at the design stage of a new building, and must be considered by the designer in advance, so that any person can feel comfortable to use it. If government invest a small amount of money and efforts to adapt people with disabilities now, they will not have to spend a lot of money on their maintenance, on the contrary, such kind of people will become autonomous and economically active citizens, bringing additional income to the country.

Moreover, I suppose that the simple allocation of benefits for disabled people does not solve the problems of these people, but rather complicates them. Social security for disabled people at the expense of the wages of the working population causes apathy, the thought of uselessness in society and the disappointment in their abilities.

In this way, the base problem of comfortable adaptation of low-mobility population can be solved by a well-designed architecture and technology project.

A small part of such kind of a projects was proposed me to decide by the "Center of rehabilitation for disabled people" in Saint Petersburg.

Not so many years ago many Russian people believed that there were no disabled people among us, who need to equip a barrier-free environment, but they just could not get out of the house and get to the hospital, the store or bank. Disability is a social phenomenon, no society can avoid it, and each state according to the level of development, priorities and opportunities forms social and economic policies for people with disabilities. In Russia there lives about 146 million people, 13 million have disabilities (that is 8,9 %).

The first document was adopted by General Assembly resolution of 9 December 1975-Declaration on the Rights of Persons with Disabilities. This document contains a definition of the concept of "disabled person" and includes a number of principles that determine the rights of the disabled person. In particular, it points to the need to ensure

full civil and political rights for the disabled, to guarantee the right to dignity, the right to take into account their needs and interests in economic and social planning, the right to protection from discrimination and all forms of exploitation, etc. But despite of this the common level of architectural preparations for people with disabilities in Russia is very poor.

The entire population of Finland is about 5 million people, about 10 percent of whom are disabled. There is a number of organizations improving the situation of disabled people in society. New houses are mostly built taking care of the possibility of residence of an invalid in it. Also there are specially equipped centers where disabled people live completely independently. From ordinary houses they are distinguished by special amenities and 24-hour staff service.

Such people comment life in Finland much more positive than in Russia. The level of arrangement of public places and private houses is much higher. Travelling by public transport for both the wheelchair user and his escort is free as in Russia, but in Finland when the bus stops, it "crouches", and there is no difficulty to roll a wheelchair or enter it to an elderly person, as the bus area becomes the same level with the stop platform, in Russia public transport absolutely is not adapted for wheelchair usage, moreover elderly people are experiencing difficulties.

For the past 40 years, the Finns have done a lot in the creation of a barrier-free environment. Until the 1970s or even the 1980s, many disabled people lived in special institutions and did not take part in public life.

1.2 Common information about target building

The examined construction is located along the eastern facade of the building of the rehabilitation center for the disabled at the address: Bolshoy Sampsonievsky prospect, 98.

This is the 5-storey brick residential building with the plastering on the facade, the total area of the building is 4741.40 m², the area of the 1st floor occupied by the center is 509.4 m². The remaining 4 floors are occupied by private apartments.

In figure 2 there is an entering group of elements, which should be renovated and adopted to the people with reduced mobility needs.

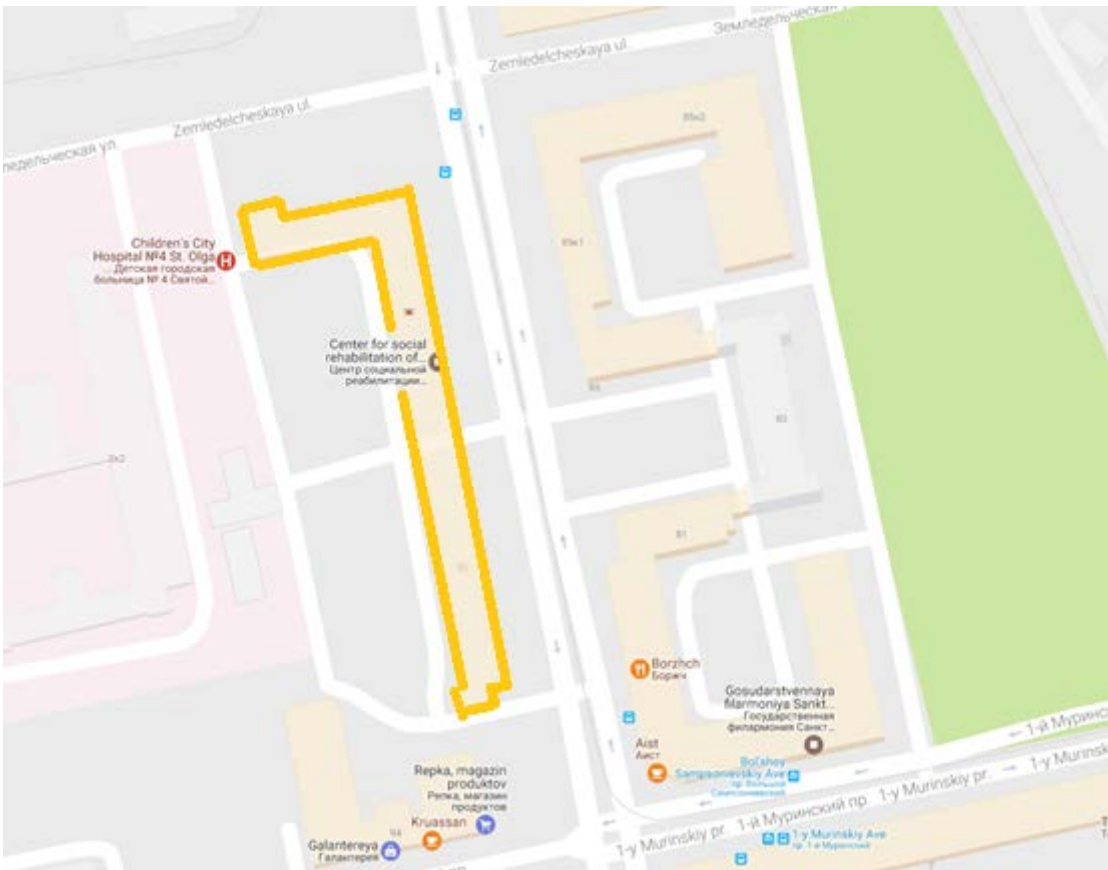

Figure 1 General plan of the building



Figure 2 Entering group of elements

The drawings of the main façade are shown in Appendix 2.

The participants of the project are shown in the table below:

Owner	<ul style="list-style-type: none">• City of Saint-Petersburg
Architect and Project planning	<ul style="list-style-type: none">• Company "Complex engineering design"
Control	<ul style="list-style-type: none">• Committee for Urban Planning and Architecture of St. Petersburg, gives Project development authorization• Leningrad State Expertise, gives approving documents for execution
User/ Customer	<ul style="list-style-type: none">• Center of rehabilitation of disabled people
Assembly organization	<ul style="list-style-type: none">• Choosing by user by results of tenders

1.3 Terminology

Barrier-free environment (design)- this term is applied to elements of the environment that people with physical, sensory or intellectual impairments can freely enter and use.

Barrier-free building- is a building suitable for using of people whose capacity to move or function is limited. Executing for purposes of equality.

Reduced-mobility persons (RMP) - People have difficulties in their own movement, receiving services, necessary information, or when orienting themselves in space. According to the Russian regulations, the following categories of citizens:

- disabled people with musculoskeletal injuries (Including disabled people using wheelchairs);
- disabled people with visual and hearing impairment;
- elderly people;
- temporarily incapacitated;
- pregnant women;
- people with baby buggies;
- children of preschool age.

CSRД- Center for Social Rehabilitation of the Disabled people.

Tactile ground indicators- displaying information things, representing a relief strip of a certain pattern and color, allowing the visually impaired to orient themselves in space by touching feet, with a cane or using residual vision. It is divided into types for road and floor, as well as for warning and guiding.

Disability is an impairment that may be cognitive, developmental, intellectual, mental, physical, sensory, or some combination of these. It substantially affects a person's life activities and may be present from birth or occur during a person's lifetime.

2 Legislation, instructions and basic concepts

2.1 Legislation in Russia

For the first time in legislative acts, an accessible environment was mentioned in Decree No. 1156 of the President of the Russian Federation of October 2, 1992 " About Measures for the Formation of an Accessible Vital Activity for the Disabled" and in the Decree of the Government of the Russian Federation No. 245 of March 25, 1993, with the same name.

These provisions were consolidated and developed in the Federal Law of November 24, 1995, No. 181-FZ "About the Social Protection of Persons with Disabilities in the Russian Federation".

The "Accessible Environment" program was developed by the President and the Government of the Russian Federation in November 2009. The state customer and coordinator of the future Program was the Ministry of Health and Social Development of the Russian Federation. Russian Prime Minister signed an order of the Government of the Russian Federation of October 27, 2014 No. 2136-r "On the extension to 2020 of the implementation of the state program" Accessible Environment. "

The main document now: Code of Regulations SP 59.13330.2012 (previously "SNIP 35-01-2001") "Accessibility of buildings and structures for persons with disabilities and persons with reduced mobility ".

2.2 Legislation in Finland

National Building Code of Finland section F1 “Barrier-free building”, including several regulations addressing administrative, service, business and work facilities.

F1 basing on:

- Land Use and Building Decree issued in Helsinki, September 10, 1999
- The Decree on housing design (RakMk G1)

Specific requirements: The National Building Code of Finland Section G1 “Housing design” on residential buildings.

2.3 Legislations and programs in Europe

The EU promotes an active inclusion and full participation of disabled people in society, in line with the EU human rights approach to disability issues. Disability is a rights issue and not a matter of discretion. This approach is also at the core of the UN Convention on the Rights of Persons with Disabilities (UNCRPD) which was negotiated during eight sessions from 2002 to 2006.

In the EU countries the problems of people with disabilities are managed by a specially created commission. The European Commission adopted in 2010 in accordance with the European Disability Strategy 2010-2020, builds on the UNCRPD.

It issues regulations that are binding on all members of the Union. These documents relate to newly constructed buildings (their availability must be 100% complete), public transport (for example, in Prague, there are specially marked trams and buses equipped with a call button for the driver), parking lots.

2.4 Elements of the entrance in the building accessed for persons with disabilities

According to the SP 59.13330.2012, in the building at least one entrance must be adapted for the disabled. This can be a central (main entrance) or a specially adapted entrance for wheelchair users.

The main elements of the entrance group are:

- entrance platform (in front of the door);
- stairs (outside);
- ramp (outdoor) or lift;
- door (entrance);
- tambour;

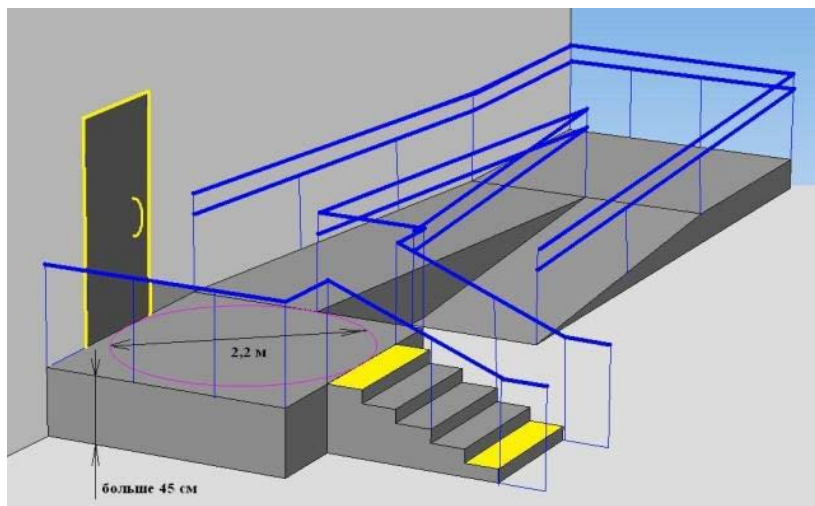

Figure 3 Common example for correct enter accessed for RMP

The entrance platform should have: a handrail, a drainage system, depending on local climatic conditions - heating of the surface of the coating. The dimensions of the platform when opening the outer door must be at least 1.4 x 2.0 m or 1.5 x 1.85 m. The dimensions of the entrance platform with a ramp should be bigger than 2.2 x 2.2 m.

Each rise of the ramp demands arranging horizontal platforms with a width not less than the width of the ramp and a length of at least 1.5 m. Covering of the ramp important to be continuous material and not slipping. Width of one-way ramps in clear is 0.9-1 m- to ensure capability of taking up with both hands.

The edges of the ramp and horizontal platforms should be provided with offsets higher than 0.05 m to prevent slipping of the wheelchair, walking stick or leg.

The handrails of the railing of ramps should be double at height 0.7 and 0.9 m. For preschool children age the handrail is at a height of 0.5 m. It is important to remember that it is easier for a disabled person to climb, holding on handrails as close as possible to each other.

External stairs and ramps should be equipped with two-sides handrails. The length of the ramp march should not exceed 9.0 m, and the slope is not steeper than 1:20.

If the ramp is straight and does not change its direction, then the width intermediate platform should be equal to the width of the ramp (900 mm), and depth not less than 1500 mm. If the ramp on the intermediate platform changes its direction to 180 °, then the depth of the site should be at least 1500 mm, and the width will be equal to the width of two adjacent marches, that is 1800 mm. Such a platform will be enough to turn the wheelchair 180 °.

The length of the handrails should be more than the length of the ramp on each side not less than 0.3 m. That should be provided, because RMP when lifting up takes the handrails on both sides of the ramp slightly ahead of the wheelchair and pushes the wheelchair upward with a sharp movement.

The surface of handrails should be continuing, uninterrupted and strict parallel to the surface of the ramp. Handrails should be of circular cross-section with a diameter not less than 4 and not more than 6 cm.

Steps of stairs should be even, without protrusions and with a rough surface. The step edge should have a radius of no more than 0.05 m. The lateral edges of the steps, not adjacent to the walls, must have offsets of a height of at least 0.02 m or other hings to prevent the cane or foot from slipping.

The size of the tread should be 0.3 m (acceptable from 0.28 to 0.35 m), and the size of the riser be 0.15 m (permissible from 0.13 to 0.17 m).

It is recommended that the first and last steps of the staircase be highlighted in yellow. The use of these techniques should not destroy the overall artistic solution of the interiors and facades. The tread and part of the riser are marked with contrasting color. The contrast marking must be bright yellow or white.

2.5 Common elements of barrier-free environment

According to statistics, every person in any period of his life needs elements of an accessible environment:

- ramps;
- handrails;
- lifts of various types;
- contrast marking of glass doors;
- alarm buttons;
- buttons for calling the seller at the shop door;
- information signs;
- duplication of reference information by Braille (for poorly seeing and blind people), etc.

Barrier-free environment is realizing with the help of wide inputs (the width of one of the door leaflets should be not less than 900 mm - 1 m). The same requirements apply to the width of the entrance to the apartment, bathroom, balcony (the depth of the balcony should be more than 1,5 meters). A special place is occupied by elevators - the entrance to the elevator should be wide enough, the doors are equipped with special sensors that do not allow closing the doors. Also, the elevator should be deep enough (1.5- 2 m) and have illuminated buttons, with Braille font on them.

The apartments designing in accordance with the norms of housing for people with reduced mobility, are equipped with wider corridors, entrances, special bathrooms and toilet rooms (one of the examples is a "sitting" bathroom, and also showers with a lowered pallet, a demountable tray). All kitchen surfaces are located at a lower level, including the hob.

In any parking lot about 10% of parking spaces are allocated for motorists with disabilities. Such places are marked with special markings, the access roads to them are as simple as possible, without curbs, narrow passageways, etc.

3 Renovated entrance solution

3.1 Inspection of structures

Photos of the surveyed items are shown in Appendix 1.

As you can see (figure. 1,3,4,5) this group of elements has considerable physical deterioration and obsolescence as a common. The material of ashlaring- ceramic tile is very slippery, does not comply with the safety regulations.

According to the results of the visual inspection, durability of the construction is recognized as workable.

Based on the results of the measurements, a drawing was made of an existing façade- Appendix 2 and the dimensions of the existing structures were analyzed.

Table 1 summarizes inconsistencies with standards found at the time of inspection:

Table 1 Results of visual-measurement survey

Structure element	Defects and inconsistencies with standards	Figure from Appendix 1
Ramp	cracks in cement-sand screed;	5
	The slope of the ramp in the existing structure is 1: 8.7, which does not comply with modern standards (SP 59.13330.2012 p.4.1.14), where the slope should not be steeper than 1:20;	4, 9
Steps of the porch	There is a width of steps 0.3 m and a variety of risers;	3
Top platform	has sizes (1.3x1.5 m) are not enough to ensure free wheelchair maneuvering;	1, 3
Railing	does not have the required two-level handrail at an altitude of 0.9 and 0.7 m and the location on both sides of	5

	movement ways.	
Drainpipe	has non-aesthetic location and draws water directly to the surface of the ramp, causes a reduction in the service life of load-bearing structures and ramp surface.	8

3.2 Structural solutions

The project provides decisions for renovation entering group for CSRD with preservation of load-bearing structures and particular demolition in accordance with SP 59.13330.2012 "Accessibility of buildings and structures for low-mobility population groups".

This part of the work includes demolition works, reinforcement of constructions, concreting of self-supporting elements; installation of a new draining system and a new entrance door.

The graphic part is reflected in Appendix 4.

3.2.1 Safety fencing and preparation of the building site.

Safety regulations must be carried out very strictly on the construction site. It must be fenced and marked with safety signs. Fencing of rack-type was chosen. The height of the protective fences of the work sites is 1.2 m. The distance between the racks is 2 m. The quantity of fencing materials is calculated and expressed in the list of materials – Appendix 6 (25-29).

3.2.2 Demolition works

To prepare surfaces and installation of new elements the following list of works should be executed:

Table 2 List of demolition works

№	Name of the work	Units	Quantity	Add. description
1	Demolition of ceramic tile surfaces	m ²	19	use a puncher
2	Metal railings	m	10	Destroy using a puncher
3	Dismanting of concrete elements	m ³	0,1	<ul style="list-style-type: none">• Bending of the ramp- The width should be the same along the ramp-1.3 m• Vertical structures under the handrails. This is demanding because size enlargement of the top platform and the desire to maintain symmetry about the door
4	Canopy top	unit	1	
5	Door frame	unit	1	1350x2200
6	Asphalt masonry	m ²	17	For new areas of enlargement structures (under stairs and ramp). Extra masonry should be laid on demolished ramp bending space.
7	Bending of the drainpipe	piece	1	Use a circular saw

3.2.3 Formworks

The frame is made in accordance with GOST 52085-2003, the dimensions of the planned surfaces are reflected on a DRG № 3. a large-panel plywood were used as a frame.

3.2.4 Setting up the frame of reinforcing

There are mainly compressive loads in structure occurs in this way the reinforcement here ensures the integrity of the frame, prevents the chipping of the concrete, increases the durability of the structures, perceives the forces from temperature deformations. The

armature is adopted constructively. The class of reinforcing steel is A 500. The diameters of bars are 10 and 12 mm. In stairs the metal grid to create a firm construction was chosen. The sizes and emplacement are reflected in the DRG № 5 and in the material list (9-13).

When installing the reinforcement, it is necessary to keep the protective layer of concrete 30 mm.

The design location of reinforcing bars and grids should be provided by the correct installation of support devices: templates, latches, stands, gaskets and linings.

3.2.5 Concreting

The existing base is cleaning from the dust. A notch is made for better adhesion. The surface is treated with a primer for the floor.

For bars № 3 (DRG № 5) drilling of holes $d = 20$ mm is performed.

Concreting should be carried out from the lower elements upwards, accompanied by vibrating concrete.

3.2.6 Draining

A new small pipe elbow must be installed, using a clip band and a pintle to anchor this structure to the wall.

To prevent overwatering of new surface materials the concrete trough should be installed in the ramp before concreting. Special end set fitting to the chosen trough should be used.

The size of elements is shown in the DRG № 4.

3.3 Architectural concept

This section deals with the appearance of the entrance group, the overhang and the location of new handrails.

Appendix 5 reflects plans and drawings as an architectural view.

The style and new composition should emphasize the unity of the architectural composition of the building.

The type of an overhang is shown in figure.4. It is represented by the steel sheet 3 mm thick arc-shaped section supported on metal profiles, the distance between which is 2500 mm. The dimensions in the plan are



2800x1600 mm. Installation in accordance with the manufacturer's recommendations.

Figure 4 Type of new overhang

The outer door is made of light-brown metal plastic according to GOST 30970-2002 with an insert of impact-resistant transparent glass at a level of 0.9 m of height.

The width of the entrance door is 1.35 m. The 1.25 m is opening part and the remaining opening (150 mm) is occupied by a dumb insert, which is part of the door frame.

Entrance doors provide a delay of automatic closing of doors with the help of closers for a duration of at least 5 seconds.



The type of the railing is shown in figure.5.

There are racks, connected with a double continuous handrails, at the height of 0.7 and 0.9 m

Figure 5 Handrails for RMP

Vertical elements are facing with granite slabs 20 mm thick, having an unpolished surface. The color is brown. The horizontal surfaces (serving for the movement of

people) are covered with granite slabs 20 mm thick, having an unpolished surface. The color is gray.

On the edges of the ramp there are 5 cm height offsets of brown granite.

In front of the porch and ramp, at a distance of 0.8 m, there are information tactile "obstacle" strips with a width of 0.5 m. The edges of the boundary steps are marked with a bright, distinctive yellow ribbon, in order to warn the person of the end of the span (Appendix 6, 30-31).

3.4 Budget estimations

The budget of building works was calculated with «A0» - software estimate-analytical complex for the issuance of estimate documentation, preparation and accounting of construction production.

To calculate the cost of construction in the program various methods are provided : basic-index, resource and others. The complex has convenient functions for promptly adjusting options for calculating the results of local estimates, which allow you to quickly respond to changes in coefficients, principles of calculation and contractual conditions.

The basis-index method for determining the cost of construction is based on the use of a system of current and forecast indices in relation to the value determined in the basic price level.

The basis-index method is most common when drawing up estimates for construction, installation and repair work. The basis-index method is used to determine the cost of construction at current prices and for payments for work performed between customers and contractors. With this method of calculation, the estimated cost is determined on the basis of unitary rates, tied to local conditions of construction. Defined in this way in the basic level of prices, the estimated cost is transferred to the current level by applying the current conversion indexes

Indexing is taking into account the factor of appreciation of the cost of construction in relation to the base level, caused by inflation in the investment and construction sector of the economy. Indices are developed by regions of the country. Regional centers of pricing monitoring and expertise in construction set monthly (or quarterly) regional indices for the relevant subjects of the Federation.

The cost estimation table is shown in the Appendix 7.

The program A0 uses prices, which were calculated in 2001 and indexed to the nowadays prices. For each work, a quotation from the base collection is selected (column 3), specifying the amount of work (column 4), taking into account units of the rates. Estimation is made in accordance with the normative documents:

1. MDS 81-35.2004 «Methods of determination the value of construction products in the territory of the Russian Federation»;
2. MDS 81-36.2004 Guidelines for using federal single rates on construction and special construction works;
3. MDS 81-25.2001 Methodical instructions for determining the value of estimate profit in construction;

Each quotation of work consists of labors salary (column 5-down), machine workers (column 6-down) salary and using of machines (column 6-up). Column 5 up is a total price from labor and machinery prices or total price of material (if we are calculating only material costs). Columns 7,8,9 are calculated by multiplying costs of unit on quantity of work. Columns 10,11 are quantity of man-hour we need to execute this work.

Below the name of the work (3) there is a different coefficient writing automatically for different kind of works. $K_{\text{OЗН}}$ - coefficient shows how prices of labour have grown as compared with 2001. $K_{\text{ЭМ}}$ - coefficient shows how prices of machinery have grown as compared with 2001. Also every work has coefficients HP and СП.

HP (OVERHEAD EXPENSES) - expenses accompanying the main production. Includes accounting fees, advertising, insurance, interest, legal fees, labor burden, rent, repairs, supplies, taxes, telephone bills, travel expenditures

СП (Estimated profit)- is the amount of funds necessary to cover expenses not directly related to this construction, but necessary for the further operation of the construction organization.

In this way to calculate the cost of the project a proper material or installation work name should be found in the base of A0 and put the amount of work/material and the program is automatically calculating the price in accordance with nowadays prices using indexes. This is the core of the basis index method.

4 Summary

The thesis deals with designing barrier-free environment. This question was considered as a regulation, and a certain project. I have tried to figure out and pay attention to the disabled persons needs. These special needs affect the architectural design of buildings and structures: special entrances is an important thing to give advantages for every person to use the opportunity of this building.

Table 3 shows the comparison of some dimensions in Russia, and Finland standards used in the project.

Table 3 Comparison of Finnish and Russian parameters

Name of parameter	SP	Finland	project
minimum going of steps, mm	from 280 to 350	About 300	350
maximum rise of steps, mm	from 120 to 170	About 160	135
Ramp slope max	1:20	1:12,5	1:20
Ramp half landings for 1:20	Demands every 9.0 m	Acceptable without half landings	without
handrailings	Continue uninterrupted on top of the other are approximately 900 mm and 700 mm. Extended 300 mm over the starting and finishing points of ramps and stairs		
entrance platform	Minimum 2.2x2.2 m	Minimum 2.3x2.3 m	2.3x2.3 m

The total price of materials and building is approximately 840 thousand rub, that at the time of 2017 is 13,5 thousand euro.

In comparison with the existing solution (Appendix 1), technologically the porch is not so much different. But the ramp is 3 times lengthened, convenient double-sided handrails are equipped, the size of the entrance area is increased. All facing materials are replaced with granite slabs - this will ensure the durability of structures, the safe movement of citizens and wheelchairs.

Figure 6 shows the 3 dimensional view of the structure modelled in Revit.

Figure 6 3d view of the target.



Russia is now in a difficult situation. This is a huge country but everything that was built before, never took into account the needs of people with disabilities.

Nevertheless, the changes are visible: sound announcements about stops are repeated visually on an interactive map, and the disabled are accompanied by specially trained employees. Gradually stations, airports, not to mention the buildings of social services are changed. Many public places in Saint-Petersburg are equipped now with ramps or lifts. There is the map of accessibility available online. There are opportunities to receive free of charge rehabilitation funds, to defend in court their rights to enjoy the benefits of society.

The barrier-free environment includes not only the absence of external visible barriers. This concept fully applies to the attitude of people in society and affects such aspects as mutual assistance, responsiveness and empathy. «Reconstruction» in the minds of people takes considerable time, like architectural reconstructing, especially in such a large country.

But I am confident that Russia will eventually join to countries with overwhelming number of buildings accessible for everyone.

Figures

Figure 1 General plan of the building	7
Figure 2 Entering group of elements	7
Figure 3 Common example for correct enter accessed for RMP	11
Figure 4 Type of new overhang.....	18
Figure 5 Handrails for RMP	18
Figure 6 3d view of the target.....	22



Tables

Table 1 Results of visual-measurement survey	14
Table 2 List of demolition works	16
Table 3 Comparison Finnish and Russian parametrs.....	21

References

1. Bases of formation accessible environment for disabled persons. Illustrated reference book. Ministry of social relations of Chelyabinsk region, Chelyabinsk 2014.
2. SP 59.13330.2011, Accessibility of buildings and structures for persons with disabilities and persons with reduced mobility, 2013. A decree by the Ministry of Regional Development of Russia. <http://docs.cntd.ru/document/1200089976>. Accessed on 29 April 2017.
3. F1 The Finnish building regulations Barrier-free Building. Regulations and Guidelines 2005. Ministry of the Environment Decree on accessible building
4. RT 09-10884, 2006.
5. SP 18.13330.2012, Public buildings and works, 2014. A decree by the Ministry of Regional Development of Russia.
6. GOST 52085-2003, Formworks, General specifications, 2003. A decree by the Rosstroy.
https://www.oхранatruda.ru/ot_biblio/normativ/data_normativ/39/39166/.
Accessed on 29 April 2017.

Appendix 1. Photo fixation of existing situation

<p>1 View B</p>	 A side-angle photograph of a porch. The porch has a dark brown, arched metal awning with decorative scrollwork. A red metal railing runs along the edge of the porch. The steps are made of grey concrete blocks. The wall behind the porch is a reddish-brown textured finish. In the background, a street with a car and another building is visible.
<p>2 Attachment porch to the wall</p>	 A close-up photograph of a window on a reddish-brown textured wall. The window is covered with a black metal grille. Below the window, there is a small, rectangular, recessed opening in the wall, possibly for a utility meter or vent. The base of the wall is a lighter, greyish concrete.
<p>3 Front view of the porch</p>	 A front-facing photograph of the porch. It shows a set of three grey concrete steps leading up to a green door. The door is framed by a dark brown metal archway with decorative scrollwork. Red metal railings are on both sides of the steps. A small red sign is visible on the wall to the left of the door. The ground in front of the steps is paved with grey bricks.



8
Drainpipe



9
Facade with
reconstructed
entrance group



Front view
M 1:50

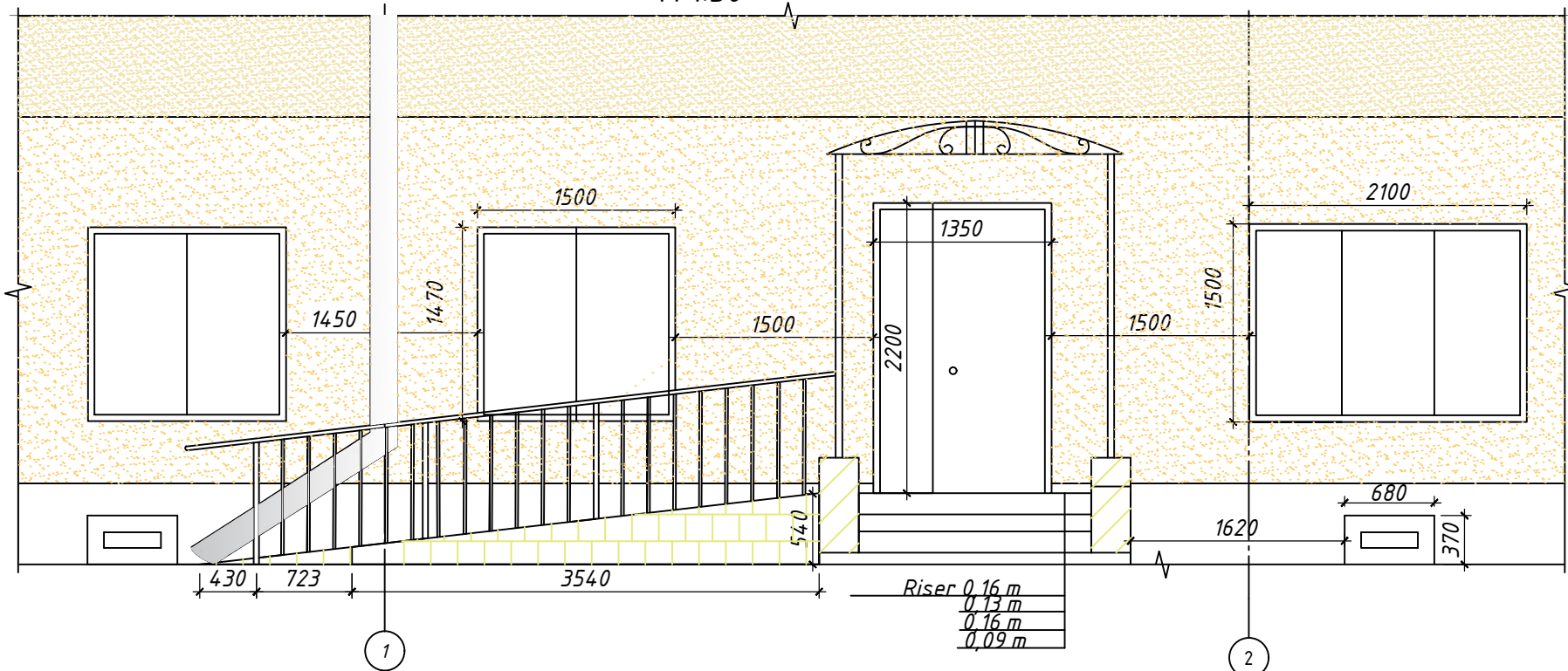

Grafical symbols

- Points of photofixation
- Facade colour N°1
- Facade colour N°2
- Horizontal surface ceramics
- Concrete structures under railings
- Grass

Plane view

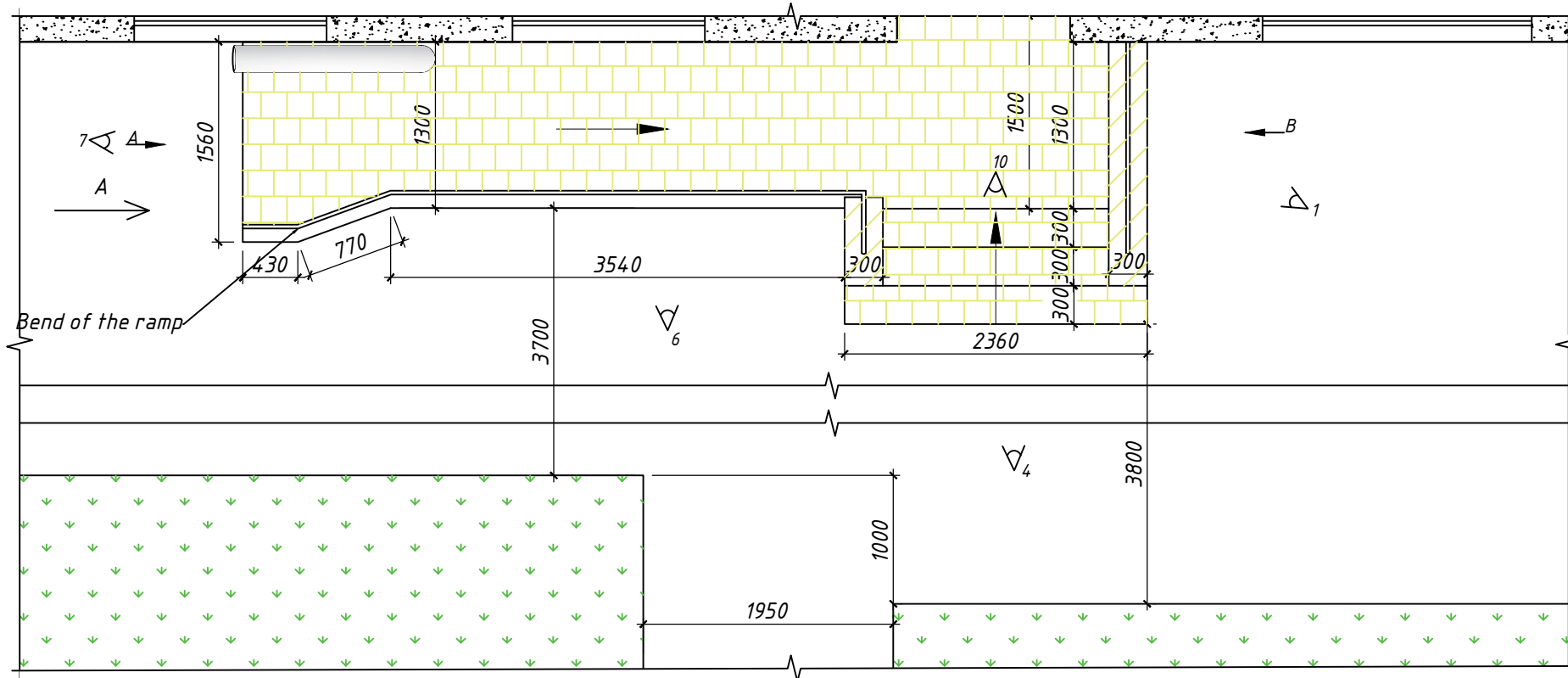

A view

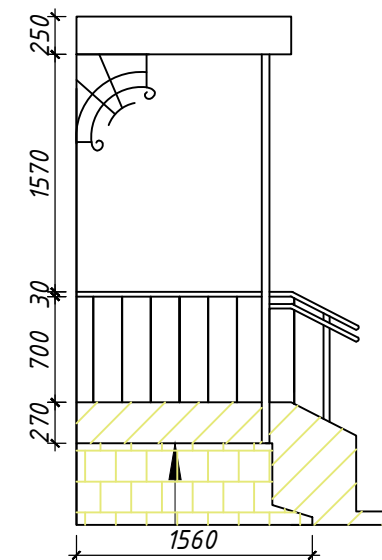

B view

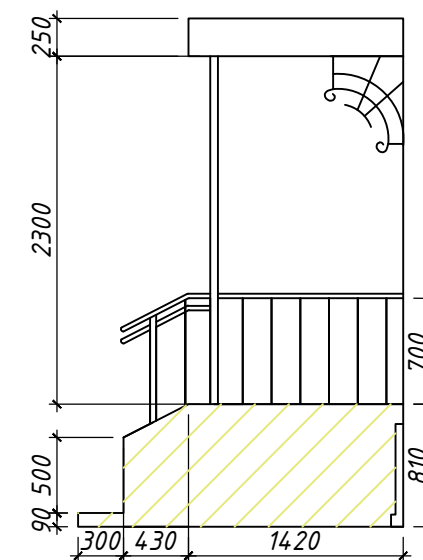

						Project of renovation the facade of the building with access for persons with disabilities			
Rev.	Partic.	DRG	№	Sign.	Date	Appendix 2		Stage	DRG No.
DRWN		Bakaeva L.						IFA	1
AP'D		Voronov A.				Measurements of the facade			Complex Engineering Design

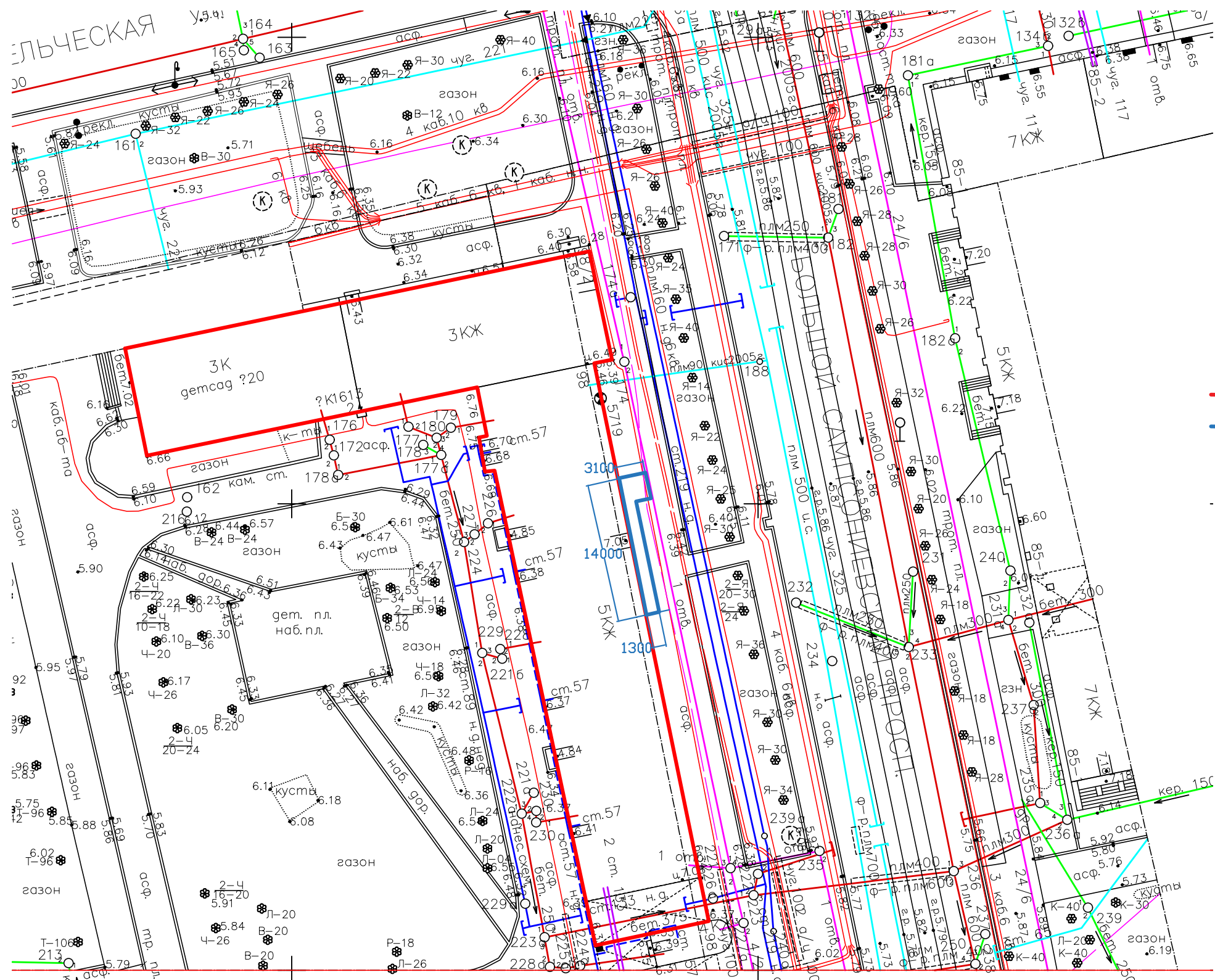

Graphical symbols

- Edges of the building
- Edge of entering group of elements renovated

Rev.	Partic.	DRG	No	Sign.	Date
DRWN		Bakaeva L.			
AP'D		Voronov A.			

Project of renovation the facade of the building with access for persons with disabilities

Appendix 3	Stage	DRG No.
	IFA	2

Plan of topographical survey
S 1:500

Complex Engineering Design

Frontal view M 1:50

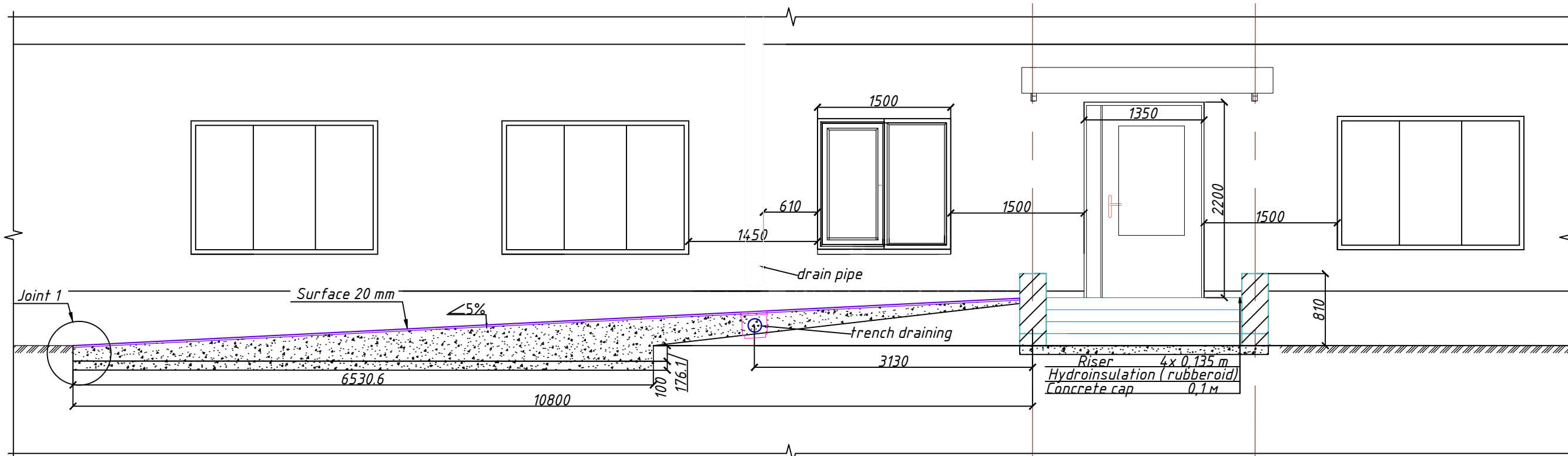

Planview

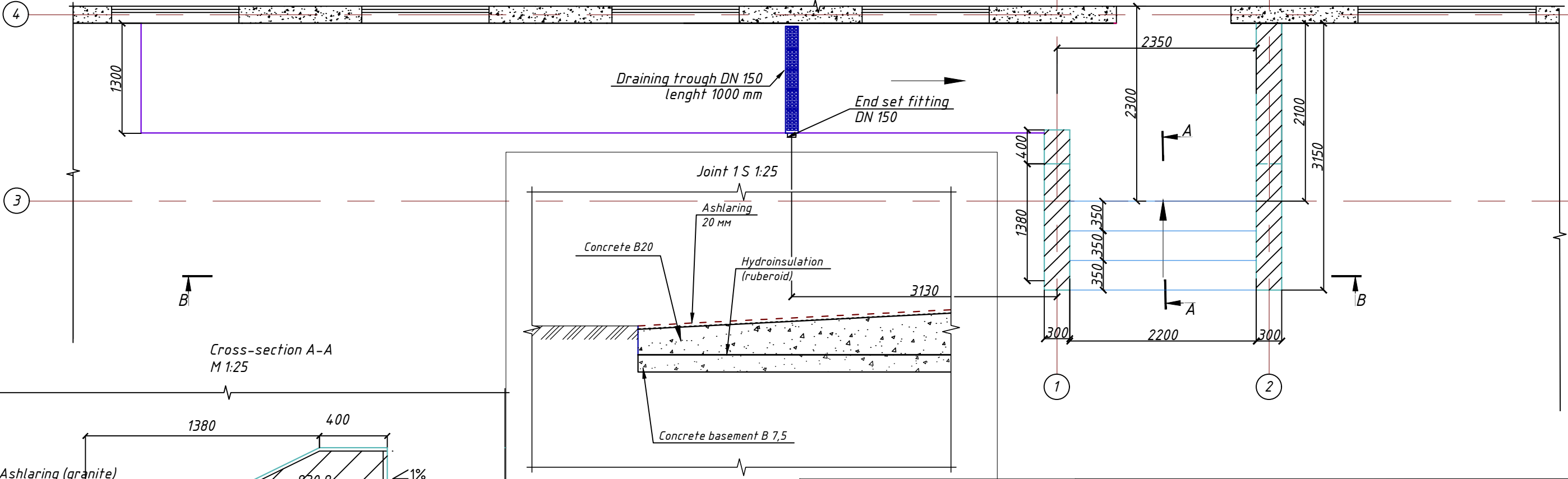

Cross-section A-A M 1:25

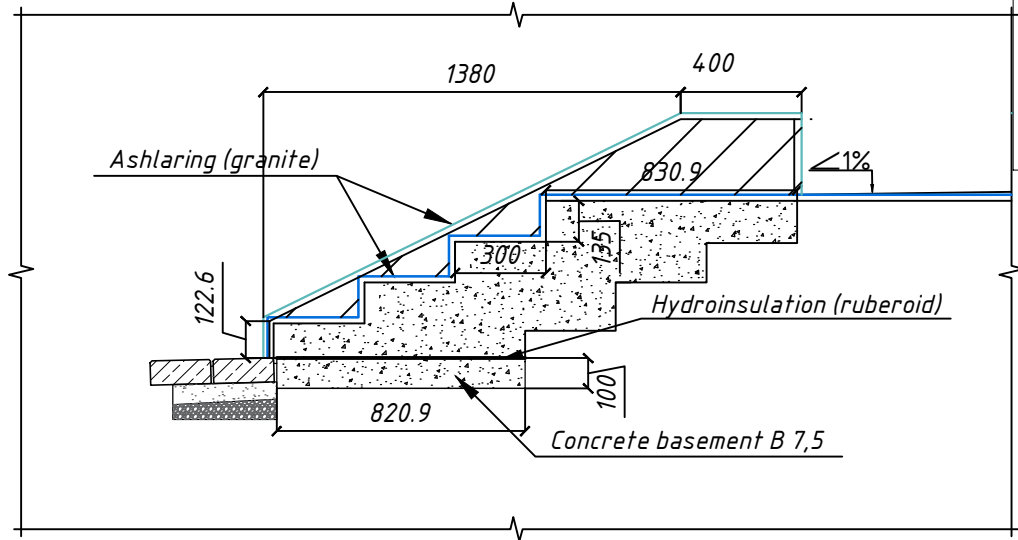

- Graphic symbols
- existing surface
 - surface of new covering
 - area of the steps concreting
 - concreting of vertical structures

Rev.	Partic.	DRG	No	Sign.	Date
DRWN		Bakaeva L.			
AP'D		Voronov A.			

Structural scheme		
Project of renovation the facade of the building with access for persons with disabilities		
Stage	DRG No.	
IFA	3	
Scheme of concreting		

BGU Universal concrete draining trough DN150, №5-0, not inclined

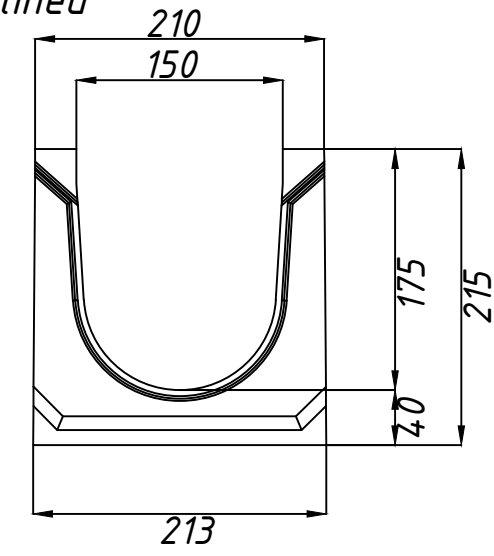
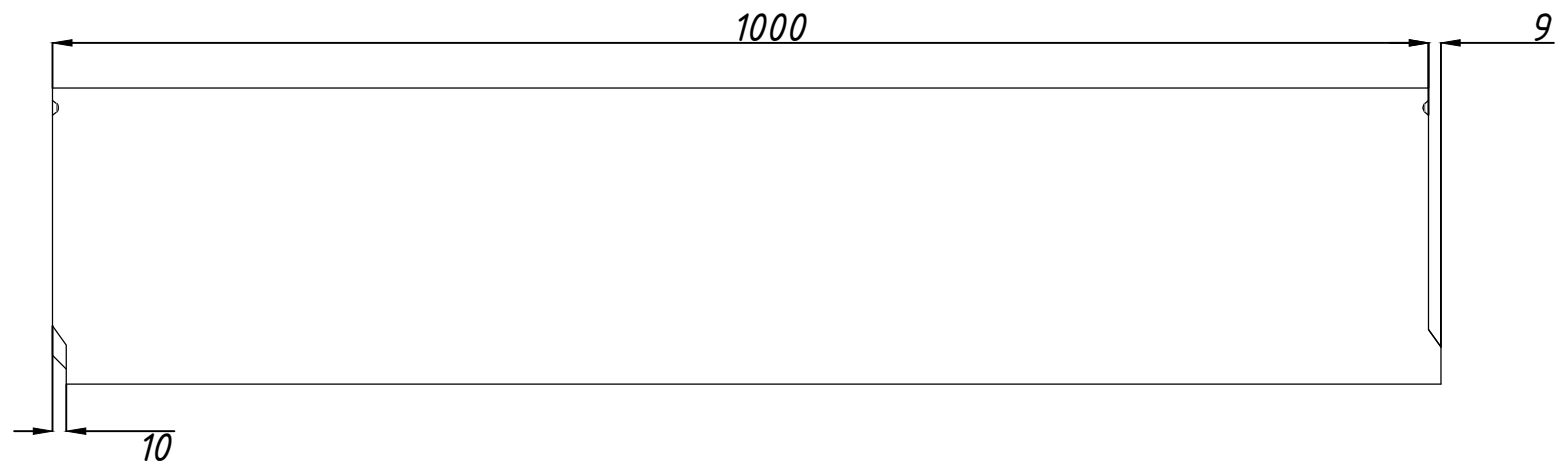

End set fitting cap with a horizontal flashing for the concrete trough DN150 steel zinc plated

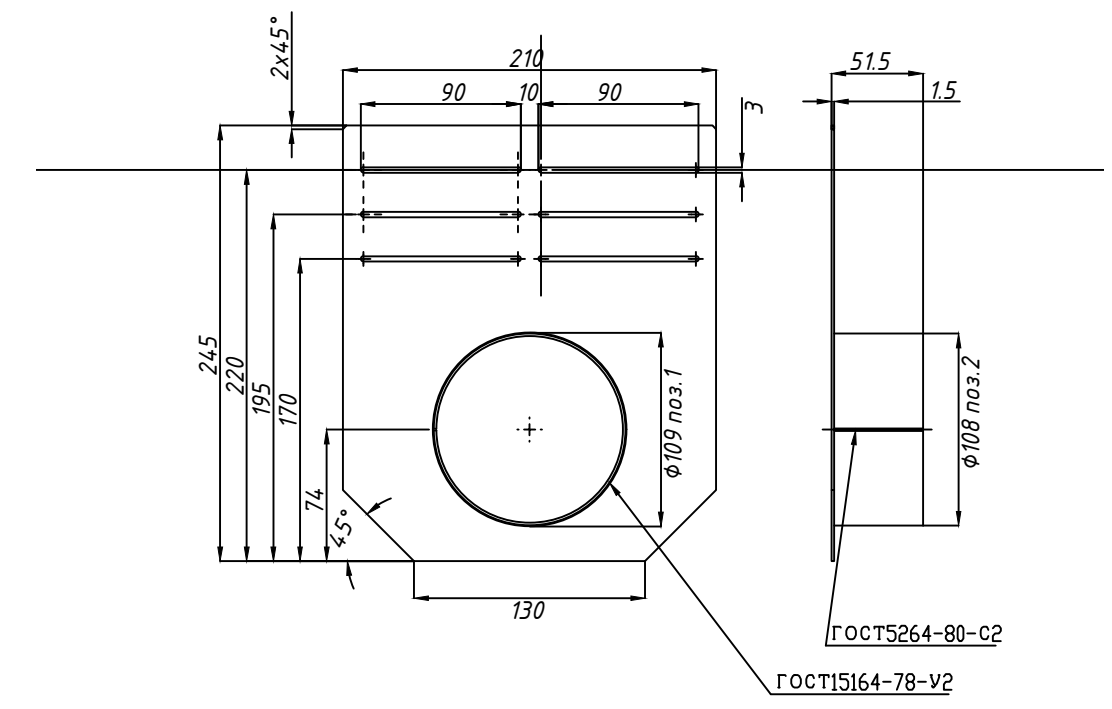
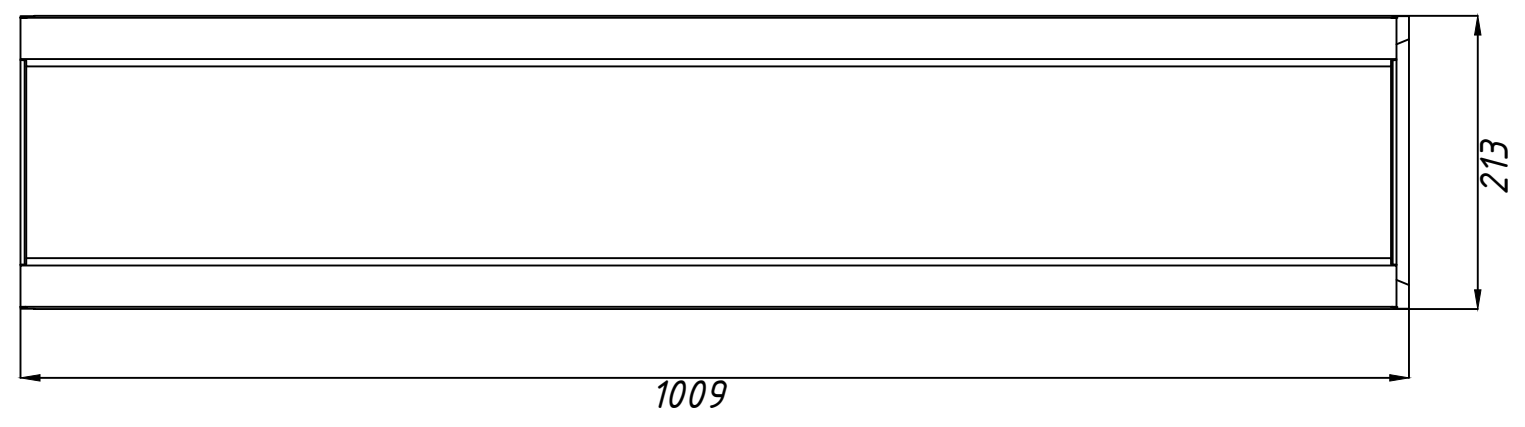

Draining grid PB-15.18,6.50 cellular cast-ironic

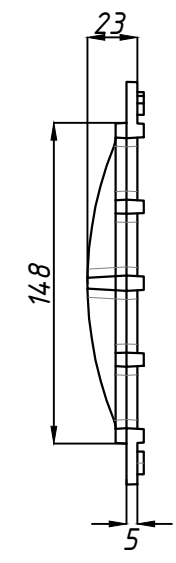
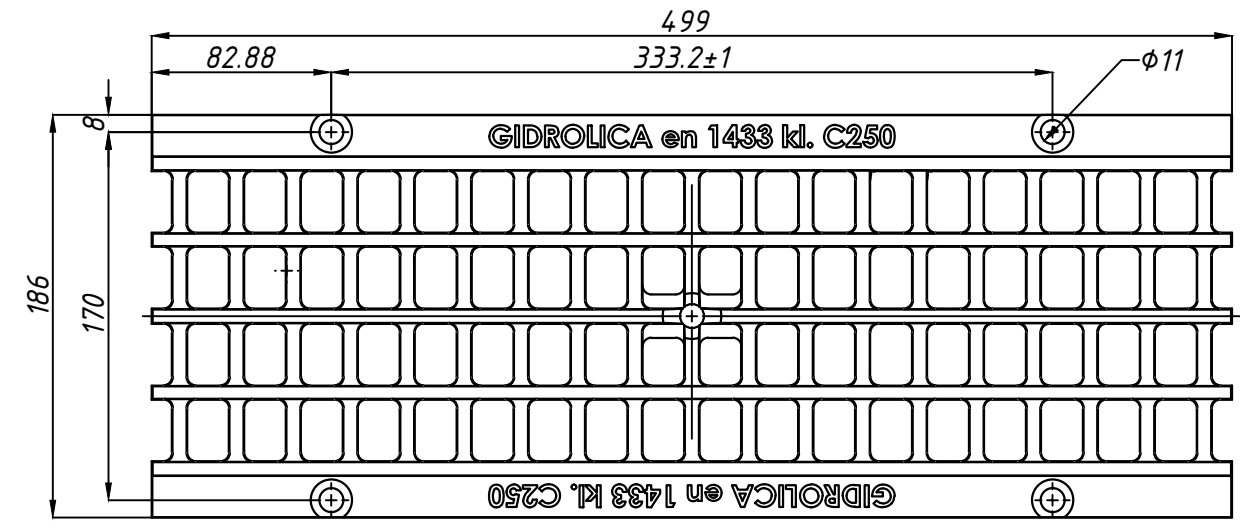

Согласовано			
Взам. инв. №			
Подпись и дата	2017-04-28		
Инв. № подл.			

Rev.	Partic.	DRG	№	Sign.	Date
DRWN		Bakaeva L.			
AP'D		Voronov A.			

Structural scheme			
Project of renovation the facade of the building with access for persons with disabilities			
Appendix 4		Stage	DRG No.
		IFA	4
Draining trough			

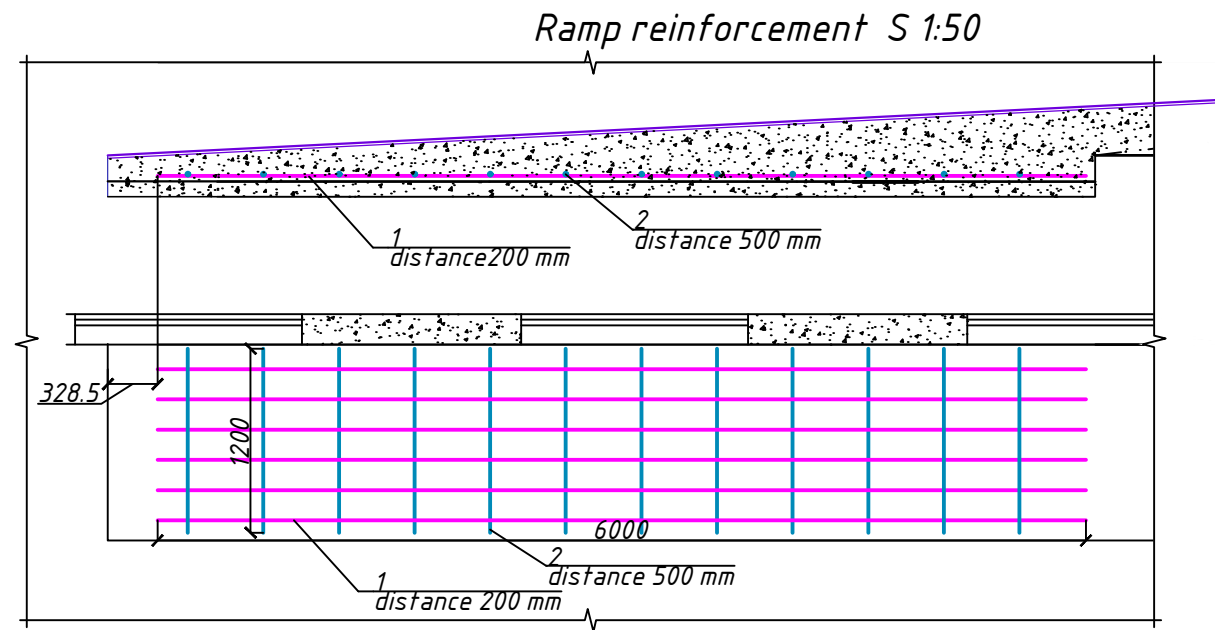

List of materials

No	Standard	Name	Value	Mass unit, kg	Information
Bars					
1	GOST P 52544-2006	Ø12 A500C L=6,000 M	6	5,33	
2	GOST P 52544-2006	Ø10 A500C L=1.200 M	12	0.740	
Details					
3	GOST 5781-82*	Armature Ø12 A500 L=1390	5	1.243	
4	GOST 23279-2012	Grid 4C (3 A500C/3 A500C) 2050x2095	1	5	
Elements					
DN150	GOST-21509-76.	Draining trough DN150	1		
Г2		Flashing pipe DN150 l 0,200 m	1		
Г3	GOST-21509-76.	Square draining grid DN150	1		
Г4	GOST-21509-76.	Tie support for pipe D 200 mm	1		

Steps S 1:50

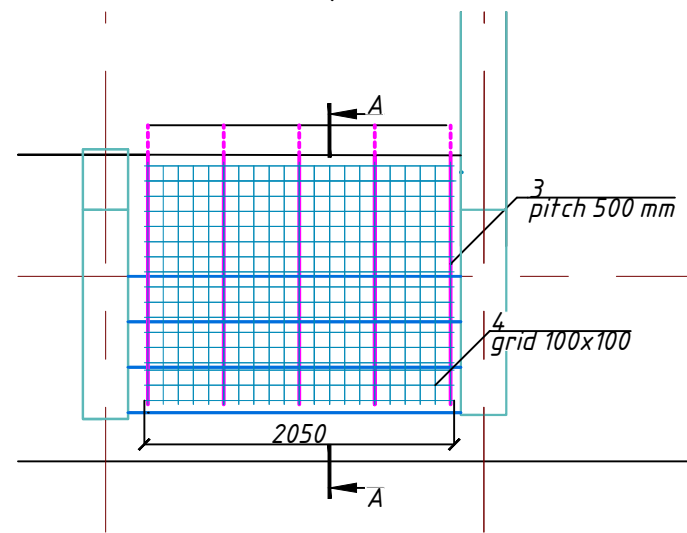

List of prefabricated elements

Nº	Draft
3 l- 1390 mm	
4 l- 2095 mm	

Cross section A-A
M 1:25

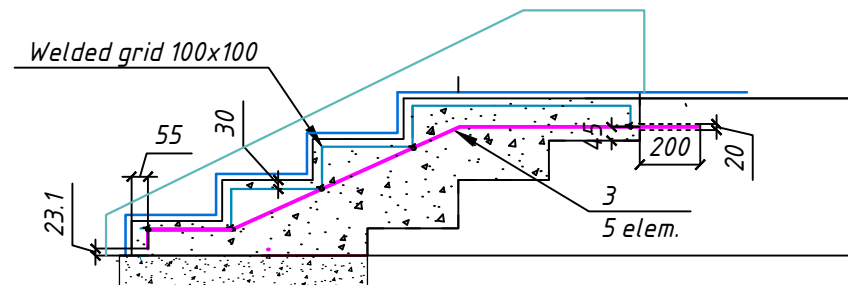

Graphic symbols

- existing surface
- longitudinal reinforcement
- cross reinforcement
- Ashlaring

Steel demand, kg.

Type of structure	Armature class					Total
	A500C					
	GOST P 52544-2006					
	dia10	dia12	dia3			
Ramp	8.88	32				41
Stairs		6,215	5			12

Structural scheme

Project of renovation the facade of the building with access for persons with disabilities

Rev.	Partic.	DRG	No	Sign.	Date			
DRWN		Bakaeva L.						
AP'D		Voronov A.						
Appendix 4						Stage	DRG No.	
Scheme of the armature installation						IFA	5	
Complex Engineering Design								

Согласовано

Взам. инв. №
Подпись и дата
2017-04-28

Инв. № подл.

A view
S 1:50

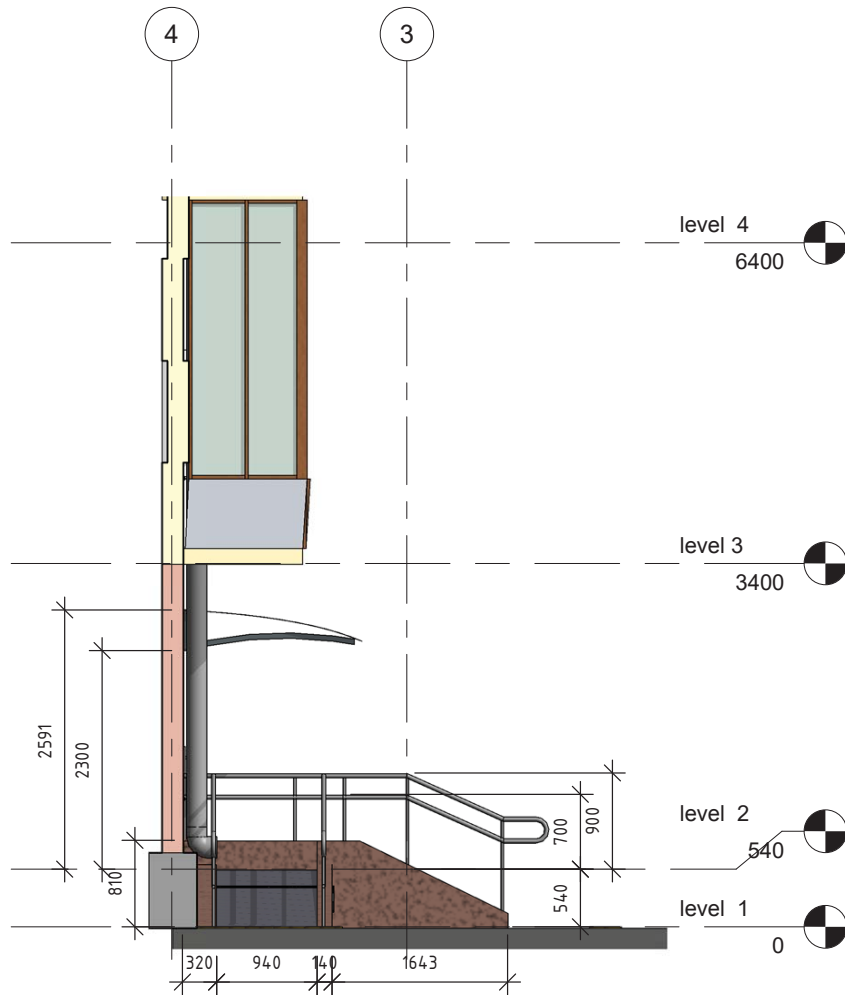

B view
S 1:50

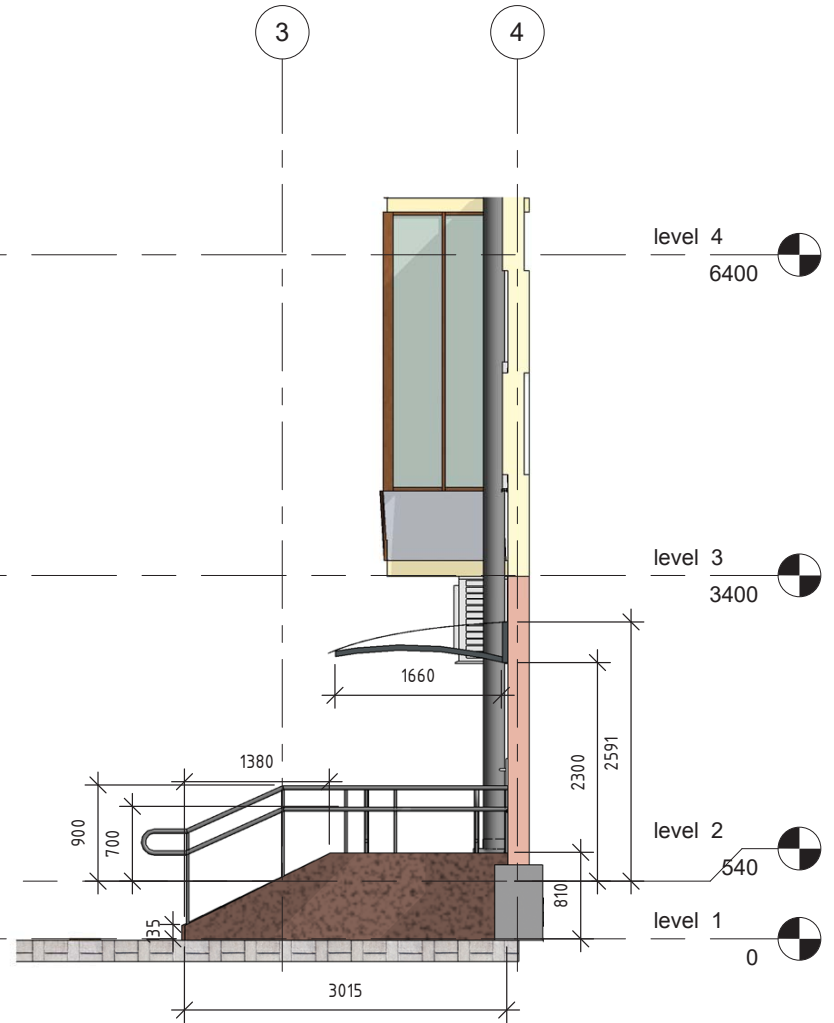

Rev.	Partic.	DRG	Nº	Sign.	Date
DRWN	Bakaeva L.				
AP'D	Voronov A.				

<i>Architectural concept</i>		
Project of renovation the facade of the building with access for persons with disabilities		
Appendix 5	Stage	DRG Nº
	IFA	7
A and B views	 Complex Engineering Design	

Details of design S 1:50

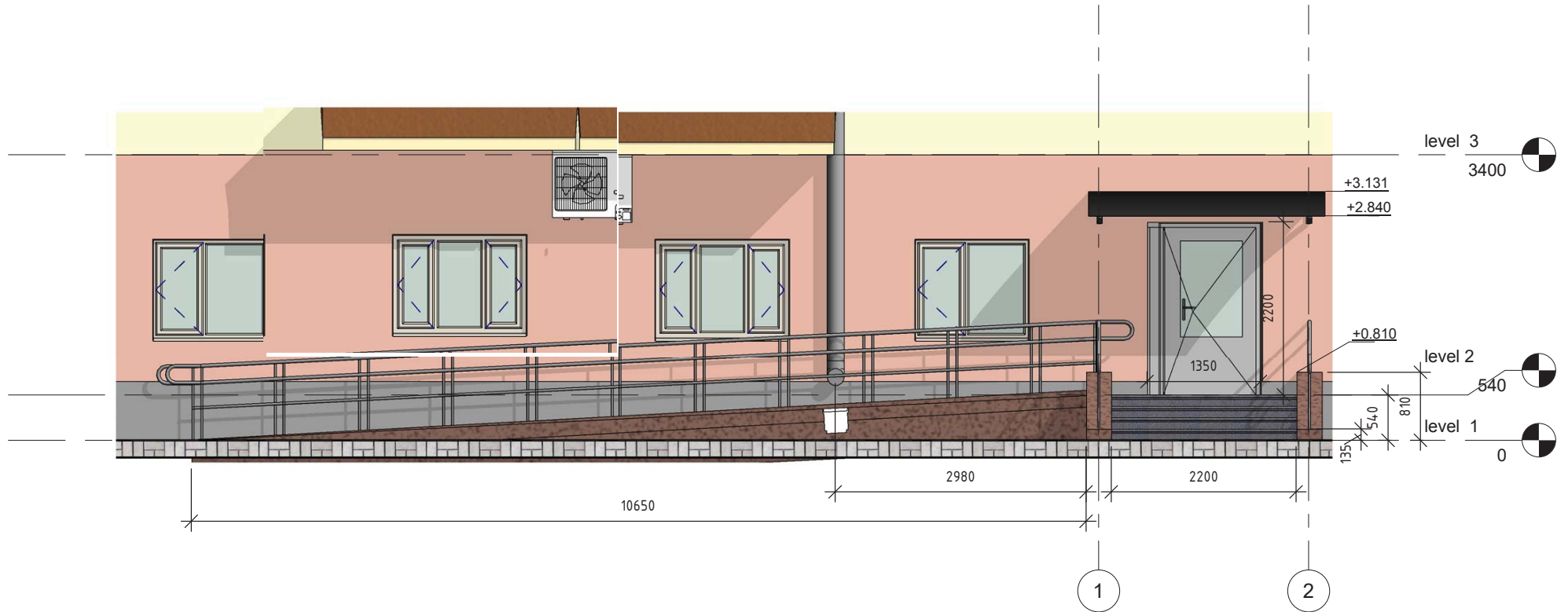

						<i>Architectural concept</i>		
						<i>Project of renovation the facade of the building with access for persons with disabilities</i>		
Rev.	Partic.	DRG	Nº	Sign.	Date	Appendix 5	Stage	DRG Nº
DRWN		Bakaeva L.					IFA	9
AP'D		Voronov A.				<i>Details of design</i>	 Complex Engineering Design	

№	Name and technical characteristics	Type, mark	№ of Standard	Code of equipment, article, material	Manufacturer	Unit of measurement	Quantity	Note
1	2	3	4	5	6	7	8	9
Ashlaring materials								
1.	Granite slabs, 300x300, 20 mm thickness, brown					m ²	13,76	
2.	Granite slabs, 300x300, 20 mm thickness, grey					m ²	17,23	
3.	Adhesive mortar for granite tiles					kg	200	
4.	Cement grout tile joints					kg	10	
5.	Clamps for leveling tiles					piece	200	
Metal elements								
6.	Metall overhang				наша-ковка.рф	piece	1	
7.	Metal railing				Пандус.су	m	26	
8.	Door metal-plastic 1350x2200 mm					piece	1	brown
Concreting								
9.	Hot rolled reinforcing steel of periodic profile of class A-III, diameter 12 mm, l= 6 m	A III				piece	6	
10.	Hot rolled reinforcing steel of periodic profile of class A-III, diameter 10 mm, l= 1,2 m	A III				piece	12	
11.	Hot rolled reinforcing steel of periodic profile of class A-III, diameter 10 mm, l= 1,4 m	A III				piece	5	
12.	Welded grid with cell 10 4C (6A500C/6A500C) 2050x2095	A III				piece	1	
13.	Concrete П2-П4, W-4, F- 100	B 20				m ³	5,42	
14.	Concrete for basement	B 7,5				m ³	1,08	

Взам. Инв. №

Подпись и дата

Инв. № подл.

		Renovation the facade of the building with access for persons with disabilities	
Developer	Bakaeva L.	Appendix 6	Sheet 1 of 2
		Materials list	 Complex Engineering design

№	Name and technical characteristics	Type, mark	№ of Standard	Code of equipment, article, material	Manufacturer	Unit of measurement	Quantity	Note
1	2	3	4	5	6	7	8	9
15.	Primer for concrete					kg	10	
<u>Water draining</u>								
16.	BGU Universal trough DN150, № 5-0			Арт. №40615061	Gidrolica	m	1	
17.	Grid water-receiving Gidrolica®Standart Д Д'-15.18,6.50 mesh cast-iron high-frequency, cl. C250			Арт. №517	Gidrolica	m	2	
18.	End set fitting DN 150			Арт.№2223 1	Gidrolica	m	1	
19.	Elbow of galvanized steel with a thickness of 0.55 mm (2 links), with a diameter 200 mm					piece	1	
20.	Coupling for the gutter, d = 200 mm, silver					piece	1	
21.	Clamp for drain pipe D 200 mm.					piece	1	
<u>Additional materials</u>								
22.	Ruberoid					m ²	10,79	
23.	Wire knitting 2 mm					m	50	
24.	Emergency guard 100					m ²	50	
25.	Milestone plastic protective fence orange 1.2 m high					piece	10	
26.	Stand under the milestone (polymer)					piece	10	
27.	Plywood 12 mm 1525x1525mm					piece.	16	
28.	Construction nails 3,0 * 70 (5kg)					pack	1	
<u>Special access for disabled</u>								
29.	Tactile tile for streets, 500x500x50, with square reefs					piece	9	
30.	Marking tape for steps, yellow					m	4,4	

Agreed:

Approved:

" ____ " _____ 2017 y.

" ____ " _____ 2017 y.

Project of renovation the facade of the building with access for persons with disabilities

(Name of the object)

Saint-Petersburg, B.Sampsonievsky prospect, 98

(Name of the site)

Local cost estimate

Renovation of entering group of elements

Basement for estimation:

Materials from constructive and architectural parts

Estimate value

building

839,35 thous.rub.

installation works

838,78 thous.rub.

equipment

0,57 thous.rub.

other works

0 thous.rub.

0 thous.rub.

Costs of labour

125,51 thous.rub.

Normative labor input

0,55 thous.man-hour

Estimations executed according to the costs of march 2017

№ n/n	Code number and normative items	Name of works and materias	Quantity and unit measuremen ts	Cost of the unit, rub.		Total costs, rub.			Labor costs of workers not engaged in servicing cars, man-hours	
				total	machinery	total	labour	machinery	for unit	total
				labour	including labour			including labour		
1	2	3	4	5	6	7	8	9	10	11

Demoition

1	TEPp-57-02-003	Ceramic tile ОЗП=728,05*18,125 ЭМ=38*14,612 Козп=18,125 Кэм=14,612 (Инд_ЦМЭЦ_03_2017) HP= 80%*0,85(HP= 1758 rub.) СП= 68%*0,8(СП= 1396 rub.)	0,19	13751,17	555,26	2613	2508	105	69,87	13,28
				13195,91	412,34			78		
2	ССЦ01-509-9900	Construction garbage	0,988							
			t							

1	2	3	4	5	6	7	8	9	10	11
3	ТЕР-07-05-016-04 МДС81-35.2004 п.4.7 Козп=1,15 Кэм=1,25 МДС 81-36.2004 п3.3.1Д Козп=0,7 Кэм=0,7 Кмат=0	Demoliion of metal ОЗП=367,49*18,125 ЭМ=184,81*9,691 Козп=18,125 Кмат=8,158 Кэм=9,691 (Инд_ЦМЭЦ_03_2017) НР= 155%*0,9*0,85(НР= 923 rub.) СП= 100%*0,85*0,8(СП= 528 rub.)	0,1	9898,58	2238,79	990	766	224	36,75	3,67
			100m	7659,79	95,16			10		
4	ТЕР-46-04-001-03	Concrete basement ОЗП=171,34*18,125 МЗ=37,3*4,809 ЭМ=414,54*8,448 Козп=18,125 Кмат=4,809 Кэм=8,448 (Инд_ЦМЭЦ_03_2017) НР= 110%*0,85(НР= 362 rub.) СП= 70%*0,8(СП= 207 rub.)	0,1	6786,95	3502,03	679	311	350	15,45	1,55
			m3	3105,54	1200,06			120		
5	ТЕР-10-01-052-04 МДС81-35.2004 п.4.7 Козп=1,15 Кэм=1,25 МДС 81-36.2004 п3.3.1Б Козп=0,8 Кэм=0,8 Кмат=0	Overhang ОЗП=43,47*18,125 ЭМ=1,44*10,789 Козп=18,125 Кмат=3,071 Кэм=10,789 (Инд_ЦМЭЦ_03_2017) НР= 118%*0,9*0,85(НР= 2691 rub.) СП= 63%*0,85*0,8(СП= 1286 rub.)	3,3	925,54	19,42	3054	2990	64	4,51	14,88
			m2 Quantity on the horizational projection	906,12						
6	ТЕРр-56-09-001	Door frame ОЗП=1757,14*18,125 ЭМ=289,79*8,49 Козп=18,125 Кэм=8,49 (Инд_ЦМЭЦ_03_2017) НР= 82%*0,85(НР= 228 rub.) СП= 62%*0,8(СП= 163 rub.)	0,01	34308,48	2460,32	343	318	25	179,3	1,79
			100 frames	31848,16	846,26			8		
8	ТЕРр-68-13-002	Demolition of asphalt masonry using choppers ОЗП=586,84*18,125 ЭМ=1309,85*7,973 Козп=18,125 Кэм=7,973 (Инд_ЦМЭЦ_03_2017) НР= 104%*0,85(НР= 209 rub.) СП= 60%*0,8(СП= 114 rub.)	0,017	21079,91	10443,43	358	180	178	57,76	0,98
			1000m2	10636,48	3346,42			57		
9	01-01-001-41 ТССЦ_ЦМЭЦ_03_2017	Loading garbage on the transportation	2,5	530,41		1326				
			t							
10	03-21-001-25 ТССЦ_ЦМЭЦ_03_2017	Transporting he garbage to the utilazing point	2,5	185,67		464				
			t							

Buiding works

11	ТЕР-06-01-001-01 МДС81-35.2004 п.4.7 Козп=1,15 Кэм=1,25	Getting-up of the concrete basement ОЗП=1717,2*18,125 МЗ=2387,93*5,511 ЭМ=1820,86*8,035 Козп=18,125 Кмат=5,511 Кэм=8,035 (Инд_ЦМЭЦ_03_2017) НР= 105%*0,9*0,85(НР= 365 rub.) СП= 65%*0,85*0,8(СП= 201 rub.)	0,0108	67241,03	18288,26	726	386	198	207	2,24
			100m3	35792,89	6443,44			70		

1	2	3	4	5	6	7	8	9	10	11
12	401-0063 ТССЦ_ЦМЭЦ_03_2017	The concrete is heavy, the size of the aggregate is 20 mm, class B7,5	1,08 m3	3206,96		3464				
13	ТЕР-06-01-001-16 МДС81-35.2004 п.4.7 Козп=1,15 Кэм=1,25	Устройство фундаментных плит железобетонных плоских ОЗП=2299,28*18,125 МЗ=707,66*5,809 ЭМ=2912,87*8,053 Козп=18,125 Кмат=5,809 Кэм=8,053 (Инд_ЦМЭЦ_03_2017) НР= 105%*0,9*0,85(НР= 2502 rub.) СП= 65%*0,85*0,8(СП= 1376 rub.)	0,0542 100м3 бетона, бутобетона	81358,1 47925,62	29321,68 9751,48	4410	2598	1589 529	253,76	13,75
14	204-0022 ТССЦ_ЦМЭЦ_03_2017	Hot rolled reinforcing steel of periodic profile of class A-III, diameter 12 mm	0,006 t	32011,58		192				
15	204-0021 ТССЦ_ЦМЭЦ_03_2017	Hot rolled reinforcing steel of periodic profile of class A-III, diameter 10 mm	0,002 t	33276,87		67				
16	204-3895 ТССЦ_ЦМЭЦ_03_2017	Welded grid with cell 10 of reinforcing steel A-I and A-II with a diameter 10 mm	0,01 t	35512,46		355				
17	101-6040 ТССЦ_ЦМЭЦ_03_2017	Сетка сварная из арматурной проволоки диаметром 4,0 мм, без покрытия, 100x100 мм	4,3 m2	66,81		287				
18	ССЦ01-401-0067	The heavy concrete , the size of the aggregate is 20 mm, class B20	5,42 m3	545,76		2958				
19	ТЕР-11-01-004-05 МДС81-35.2004 п.4.7 Козп=1,15 Кэм=1,25	Hydro insulation ОЗП=360,86*18,125 МЗ=739,33*8,487 ЭМ=134,1*7,818 Козп=18,125 Кмат=8,487 Кэм=7,818 (Инд_ЦМЭЦ_03_2017) НР= 123%*0,9*0,85(НР= 1178 rub.) СП= 75%*0,85*0,8(СП= 639 rub.)	0,1079 100m2	15106,86 7521,68	1310,49 64,34	2493	1242	216 11	31,02	5,12
20	ТЕР-15-01-001-05 МДС81-35.2004 п.4.7 Козп=1,15 Кэм=1,25	Covering of walls with a granite slabs, brown ОЗП=31299,87*18,125 МЗ=4428,56*6,367 ЭМ=164,12*11,897 Козп=18,125 Кмат=6,367 Кэм=11,897 (Инд_ЦМЭЦ_03_2017) НР= 105%*0,9*0,85(НР= 71979 rub.) СП= 55%*0,85*0,8(СП= 33290 rub.)	0,1376 100m2	683043,98 652406,67	2440,67 1476,51	93987	89771	336 203	2728,95	375,5
21	509-1784 ТССЦ_ЦМЭЦ_03_2017	Milestone plastic protective fence, orange, 1.2 m high	10 units	97		970				
22	412-9176-593П ТССЦ_ЦМЭЦ_03_2017	Granite slabs, 300x300, 20 mm thickness, brown	13,76 m2	3488,89		48007				
23	ТЕР-27-07-008-04 МДС81-35 2004	Covering of walls with a granite slabs, grey ОЗП=3311 78*18 125 МЗ=4 36*12 695 ЭМ=14012 96*7 078	0,1723	193064,92	123979,66	33265	11894	21361	335,26	57,77

1	2	3	4	5	6	7	8	9	10	11
	п.4.7 Козп=1,15 Кэм=1,25	Козп=18,125 Кмат=12,695 Кэм=7,078 (Инд_ЦМЭЦ_03_2017) НР= 142%*0,9*0,85(НР= 16068 rub.) СП= 95%*0,85*0,8(СП= 9582 rub.)	100m2	69029,91	16524,11			2847		
24	407-0028 ТССЦ_ЦМЭЦ_03_2017	Sand-cement mixture	1,947 m3	2869,61		5587				
25	101-9427-001П ТССЦ_ЦМЭЦ_03_2017	Emergency guard	50 m	60		3000				
26	412-9176-602П ТССЦ_ЦМЭЦ_03_2017	Granite slabs, 300x300, 20 mm thickness, grey	17,23 m2	3488,89		60114				
27	-прайс-	Marking tape for steps, yellow Price=1090/1,18 Кпз=1/1,18 (НДС-18%)	1 roll	923,73		924				
28	-прайс-	Tactile tile for streets, 500x500x50, with square reefs ЦЕНА=280/1,18 Кпз=1/1,18 (НДС-18%)	11 pieces	237,29		2610				
29	ТЕР-10-01-052-04 МДС81-35.2004 п.4.7 Козп=1,15 Кэм=1,25	Getting up the overhang ОЗП=54,34*18,125 МЗ=87,72*3,071 ЭМ=1,8*10,789 Козп=18,125 Кмат=3,071 Кэм=10,789 (Инд_ЦМЭЦ_03_2017) НР= 118%*0,9*0,85(НР= 3364 rub.) СП= 63%*0,85*0,8(СП= 1607 rub.)	3,3 m2	1426,32 1132,65	24,28	4707	3738	80	5,64	18,6
30	-прайс-	Metal overhang Price=24300/1,18 Кпз=1/1,18 (НДС-18%)	1 unit	20593,22		20593				
31	ТЕР-07-05-016-04 МДС81-35.2004 п.4.7 Козп=1,15 Кэм=1,25	Getting up metal railings ОЗП=524,98*18,125 МЗ=28536,42*8,158 ЭМ=264,02*9,691 Козп=18,125 Кмат=8,158 Кэм=9,691 (Инд_ЦМЭЦ_03_2017) НР= 155%*0,9*0,85(НР= 3427 rub.) СП= 100%*0,85*0,8(СП= 1958 rub.)	0,26 100m of railing	246940,93 10942,55	3198,27 135,94	64205	2845	832 35	52,5	13,65
32	-прайс-	Metal railing ЦЕНА=6200/1,18 Кпз=1/1,18 (НДС-18%)	26 m	5254,24		136610				
33	ТЕР-10-01-047-01 МДС81-35.2004 п.4.7 Козп=1,15 Кэм=1,25	Getting up new door frame ОЗП=2176,83*18,125 МЗ=14809,07*4,534 ЭМ=415,4*10,212 Козп=18,125 Кмат=4,534 Кэм=10,212 (Инд_ЦМЭЦ_03_2017) НР= 118%*0,9*0,85(НР= 1223 rub.) СП= 63%*0,85*0,8(СП= 584 rub.)	0,0297 100m2	117820,2 45373,3	5302,58 375,87	3499	1348	157 11	231,15	6,87
34	-прайс-	Door frame block 2,97m2 Price=38000/1,18	1	32203,39		32203				

1	2	3	4	5	6	7	8	9	10	11
		Клз=1/1,18 (НДС-18%)	unit							
35	ТЕР-27-02-004-01 МДС81-35.2004 п.4.7 Козп=1,15 Кэм=1,25	Installing the water drain trough ОЗП=1741,48*18,125 МЗ=1192,25*6,817 ЭМ=4892,95*7,401 Козп=18,125 Кмат=6,817 Кэм=7,401 (Инд_ЦМЭЦ_03_2017) НР= 142%*0,9*0,85(НР= 564 rub.) СП= 95%*0,85*0,8(СП= 336 rub.)	0,01	89692,44	45265,9	897	363	453	195,39	1,95
			100m	36298,97	15353,01			154		
36	-прайс-	Trough DN150, № 5-0,, uninclined ЦЕНА=1349/1,18 Клз=1/1,18 (НДС-18%)	1	1143,22		1143				
			unit							
37	-прайс-	Grid water-receiving Gidrolica@Standart PB-15.18,6.50 mesh cast-iron high-frequency, cl. C250 Price=864,8/1,18 Клз=1/1,18 (НДС-18%)	1	732,88		733				
			unit							
38	-прайс-	End set fitting DN 150 ЦЕНА=1120/1,18 Клз=1/1,18 (НДС-18%)	1	949,15		949				
			unit							
39	ТЕРр-58-10-003	The change of the bends of drain pipes ОЗП=665,84*18,125 МЗ=1,33*13,85 ЭМ=7,19*10,805 Козп=18,125 Кмат=13,85 Кэм=10,805 (Инд_ЦМЭЦ_03_2017) НР= 83%*0,85(НР= 86 rub.) СП= 65%*0,8(СП= 63 rub.)	0,01	12164,46	77,69	122	121	1	63,9	0,64
			100units	12068,35						
40	101-9953-043П ТССЦ_ЦМЭЦ_03_2017	Elbow of galvanized steel with a thickness of 0.55 mm (2 links), with a diameter 200 mm	1	446,66		447				
			unit							

Total estimations:

537111

121379

26169

532,22

4133

	Wages of workers	1	121379
	Wages of machine workers	1	4133
	Machine exploitation	1	26169
	Materials according with actual costs	1	68800
	Materials not in according with actual costs	1	318973
	Transporting of cargos	1	1790
	Total, in according with actual costs		537111
	Overheads of worker wages	1	106927
	Estimated profit	1	53330
	Total		697368
	Unexpected work and expenses	2 %	13947
	Total without VAT		711315
	VAT	18 %	128036,7
	total cost estimation		839351,7