

**Hygrothermal behaviour of timber-framed exterior walls  
adjacent to wet rooms**  
*A comparative study of different waterproofing membranes*



Bachelor's thesis

Degree Programme: Construction Engineering

Visamäki, winter 2017

Jens Kieling

Construction Engineering  
Visamäki

---

<b>Author</b>	Jens Kieling	<b>Year</b> 2017
<b>Title</b>	Hygrothermal behaviour of timber-framed exterior walls adjacent to wet rooms	
<b>Supervisor</b>	Tapio Korkeamäki	

---

ABSTRACT

This study analysed the hygrothermal behaviour of timber-framed exterior walls adjacent to wet rooms exposed to critical Finnish climatic conditions. It examined the impact of water vapour transported by diffusion from a wet room into the wall structure.

The first part of the thesis outlines the background needed for the above mentioned topic. Information about energy efficiency, insulation and moisture standards are given.

An experimental and a calculational analysis were done to compare the results. The experimental analysis was done, using a weather simulation chamber to simulate specific climate conditions. During the experimental phase sensors were tracking the humidity and temperature at relevant positions inside the wall structure. The calculational part was done in two parts. The first part concerned heat conduction and the second one dealt with diffusive moisture transfer in porous material.

The following are the main results of this thesis:

- In Finnish climatic conditions timber-framed walls can be exposed to a very high level of diffusive vapour transport from the inside-out.
- The moisture performance of a timber-framed external wall depends especially on the water vapour resistance of the materials used.
- In case of localized moisture leaks, water can easily penetrate into the wall structure and cause damages to the wall structure in the longer term.

**Keywords** Timber frame wall, stone wool, moisture transport, heat transport

**Pages** 34 pages including appendices 75 pages

# CONTENTS

1	INTRODUCTION .....	1
2	BACKGROUND.....	2
2.1	Energy efficiency .....	2
2.1.1	European energy strategy .....	2
2.1.2	Energy efficiency in buildings .....	3
2.1.3	Energy efficiency standards in Finland and Germany .....	4
2.2	Insulation.....	5
2.2.1	Need for Insulation .....	5
2.2.2	Insulation standards .....	6
2.2.3	Thermal resistance (R-value) and thermal transmittance (U-Value) .....	7
2.3	Moisture.....	8
2.3.1	Moisture performance of walls .....	8
2.3.2	Moisture in air .....	9
2.3.3	Moisture Transfer (water vapour diffusion).....	11
2.3.4	Moisture transport in Finnish climate .....	13
3	METHODOLOGY OF EXPERIMENT .....	14
3.1	Wall construction .....	14
3.2	Waterproofing membranes .....	15
3.3	Zones and placement of sensors.....	15
3.4	Procedure .....	17
4	TEST RESULTS.....	18
4.1	Stage 1.....	18
4.1.1	Temperature.....	22
4.1.2	Moisture .....	22
4.2	Stage 2.....	23
4.3	Examination.....	29
4.4	Thermal Bridges .....	29
5	CONCLUSION AND DISCUSSION .....	31
5.1	Main results.....	31
5.2	Improvements of experiment .....	32
	REFERENCES.....	33

## Appendices:

### Appendix 1 Construction drawings:

- Wall Construction
- Sensors and Zones
- Drilling Positions

### Appendix 2 Calculations

### Appendix 3 Sensor Results

## 1 INTRODUCTION

Climate change is one of the most important problems in the 21<sup>st</sup> century. Increasing greenhouse gas emissions (especially CO<sub>2</sub>) are leading to rising temperatures worldwide, which will affect the environment permanently. To mitigate climate change and lower CO<sub>2</sub>-emissions in the building sector energy-efficient building design is of most importance.

According to the Centre for European Policy Studies (CEPS) energy-efficient insulation in new buildings is the most efficient and cost-effective way to achieve this. (PU EUROPE, 2008)

To preserve the effectiveness of a building's insulation, we need to properly control the moisture flow in it. Moisture problems can not only reduce the energy-efficiency of a building, but also lower the quality of living and can cause damages to a building structure. (Hall, 2010)

Especially in cold climate water vapour inside a building is driven outside through the exterior walls. The water vapour condenses into liquid water, when it reaches a surface that is below the dew point. If this moisture stays inside a wall structure, over time it can produce mould and significantly reduces the insulating performance of an insulation layer. (Gibson, 2010)

The primary aim of this thesis was to test the moisture and heat transport inside a timber frame wall using an experimental set-up. This wall should be exposed to critical Finnish weather conditions on the cold side and to very high humidity on the warm side (comparable to conditions in bathrooms).

Secondary aims were to:

- compare two waterproofing membranes
- determine the effect of a vapour barrier in addition to the waterproofing membrane on the warm side of the wall
- determine solutions for commonly made mistakes in a timber frame wall design

The thesis is written in four sections. The first section deals with energy efficiency in Europe and the background needed to understand moisture and heat transfer inside a building structure. Section 2 explains the methodology of the experiment and describes all work stages in chronological order. The third section includes the experimental results and section 4 the conclusion. Construction drawings, calculations and sensor data can be obtained from Appendices 1-3.

## 2 BACKGROUND

### 2.1 Energy efficiency

#### 2.1.1 European energy strategy

According to the European Commission the EU aims to reduce its greenhouse gas emissions by at least 20%, increase the share of renewable energy to at least 20% of consumption, and achieve energy savings of 20% or more by the year 2020. They call it the '2020 Energy Strategy.

The EU wants to mitigate climate change and air pollution, decrease its dependence on foreign fossil fuels, and keep energy affordable.

The priorities of the 2020 Energy Strategy are:

- “Making Europe more energy efficient by accelerating investment into efficient buildings, products, and transport. This includes measures such as energy labelling schemes, renovation of public buildings, and eco-design requirements for energy intensive products.
- Building a pan-European energy market by constructing the necessary transmission lines, pipelines, LNG terminals, and other infrastructure. Financial schemes may be provided to projects which have trouble obtaining public funding. By 2015, no EU country should be isolated from the internal market.
- Protecting consumer rights and achieving high safety standards in the energy sector. This includes allowing consumers to easily switch energy suppliers, monitor energy usage, and speedily resolve complaints.
- Implementing the Strategic Energy Technology Plan – the EU's strategy to accelerate the development and deployment of low carbon technologies such as solar power, smart grids, and carbon capture and storage.
- Pursuing good relations with the EU's external suppliers of energy and energy transit countries. Through the Energy Community, the EU also works to integrate neighbouring countries into its internal energy market.” (European Commission, 2010)

In 2014 the 2020 Energy Strategy has been renewed for the period between 2020 and 2030. For the year 2030 the EU targets:

- “a 40% cut in greenhouse gas emissions compared to 1990 levels
- at least a 27% share of renewable energy consumption
- at least 27% energy savings compared with the business-as-usual scenario.” (European Commission, 2014)

The EU's long-term aim is to achieve an 80% to 95% reduction in greenhouse gases by 2050 compared to the levels of 1990.

### 2.1.2 Energy efficiency in buildings

Buildings are responsible for 40% of energy consumption and 36% of CO<sub>2</sub> emissions in the EU. Especially old buildings raise this average. While new buildings consume fewer than ca. five litres of heating oil per square meter per year, old buildings need about 25 litres (sometimes up to 60 litres).

At the moment about one third of all buildings in the EU are older than 50 years. By improving the energy efficiency of buildings, the European Commission predicts a reduction of energy consumption of 5-6% and a CO<sub>2</sub> emission reduction 5%.

The five key laws corresponding to the Energy Performance of Buildings Directive are:

- “energy performance certificates are to be included in all advertisements for the sale or rental of buildings
- EU countries must establish inspection schemes for heating and air conditioning systems or put in place measures with equivalent effect
- all new buildings must be nearly zero energy buildings by 31 December 2020 (public buildings by 31 December 2018)
- EU countries must set minimum energy performance requirements for new buildings, for the major renovation of buildings, and for the replacement or retrofit of building elements (heating and cooling systems, roofs, walls and so on)
- EU countries have to draw up lists of national financial measures to improve the energy efficiency of buildings.” (European Commission, 2012)

Energy-efficient buildings are designed to use as little energy as possible. This can be achieved by using quality insulation materials to prevent heat losses and by avoiding or minimizing thermal bridges.

“Energy-efficient buildings are classified into four categories: Low Energy, Passive, Zero and Plus Energy buildings. Passive buildings are often the optimal solution when considering the lifecycle of a building.” (Paroc Group Oy, 2017) Passive buildings allow energy savings of over 75% compared with average new buildings (less than 1.5 litres heating oil per square meter). The definition of passive buildings varies in European countries. It is based on its primary energy demand in kWh/m<sup>2</sup>a (see Table 1).

Table 1. passive building definition in Finland, Norway, Sweden and Germany (Paroc Group Oy, 2017)

Country	Space heating and cooling energy demand	Primary energy demand	Heating power demand	Air tightness 50 Pa
	kWh/m <sup>2</sup> a	kWh/m <sup>2</sup> a	W/m <sup>2</sup>	exch/h
Finland	20 - 30	130 - 140		0.6
Norway	15 + 3.5(T - 5) T = annual temperature			
Sweden	South 45 North 55 Total purchased energy		South 10 North 14	~0.6 (0.3 l/sm <sup>2</sup> )
Germany	15	120		0.6
Southern Europe	15 + 15 = 30	120		0.6

### 2.1.3 Energy efficiency standards in Finland and Germany

Table 2 shows the development of the allowed U-values in Finland. The lack of proper insulation in old buildings is based on the low standards in their construction years. To achieve for example the U-value standard for an external wall in 1985 for a timber frame wall (Hybrid Timber Frame with brick finish) an insulation thickness of only 60mm would be sufficient. Today (C3/2010) this layer has to be at least 140mm thick (This has been calculated using the Rockwool U-Value Calculator (Rockwool, 2017)).

Table 2. The rapid development of allowed U-values in C3-part (insulation) and D3-part (energy efficiency and calculation of consumption) of national building code of Finland across the years (Sirviö & Illikainen, OAMK, 2015)

U-value	C3/1985	C3/2003	C3/2007	C3/2010 D3/2012
External wall	0.28	0.25	0.24	0.17
Upper (roof) or base floor against outdoor air	0.22	0.16	0.15	0.09
Base floor towards crawl space	0.22	0.20	0.19	0.17
Structure against ground	0.36	0.25	0.24	0.16
Window or door	2.1 (0.7)	1.4	1.4	1.0
Roofwindow		1.5	1.5	1.0
Surface area of windows	max 15 % of floor area, max 70 % of external wall area	max 15 % of floor area, max 50 % of total external wall area	max 15 % of floor area, max 50 % of external wall area	max 15 % of floor area, max 50 % of external wall area





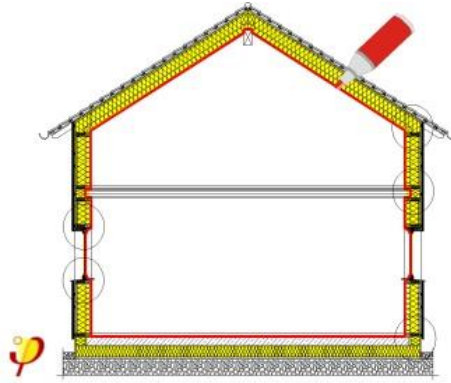

Figure 2. Energy efficient building envelope ( (Passive House Institute, 2017)

### 2.2.2 Insulation standards

Standards for thermal insulation vary all over Europe (see Figure 4). They depend mainly on the different climate conditions of a region. Figure 3 illustrates the heating and cooling degree days of the European countries. “Heating degree days express the severity of the cold over a specific time period taking into consideration outdoor temperature and room temperature.” (ECOFYS, 2007)

In Europe, Finland belongs to the countries with the highest Heating degree days per year.

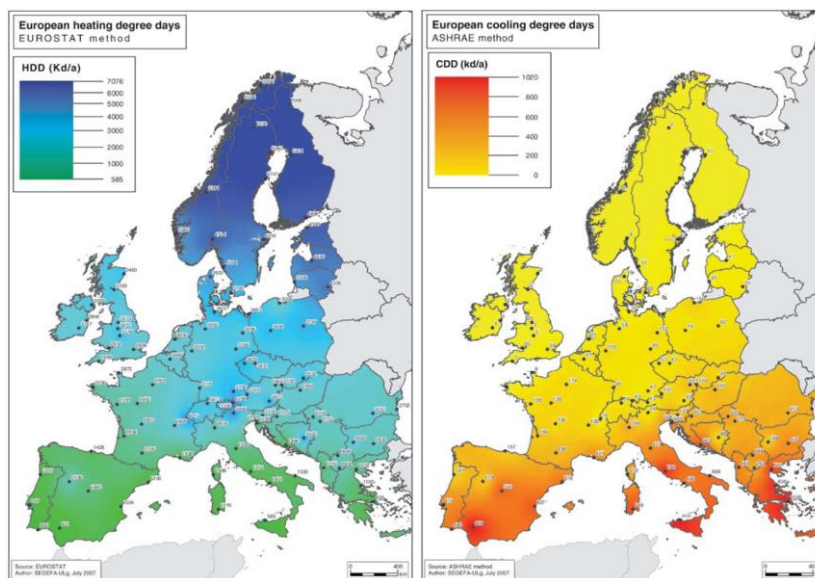

Figure 3. European heating and cooling degree days maps (ECOFYS, 2007)

The insulation thickness of walls has been increasing since in the 1970’s the first buildings with modern insulation started to appear in Northern and Central Europe. In warmer climate regions (Southern Europe) the need for higher insulation thicknesses is not as big (ECOFYS, 2002)

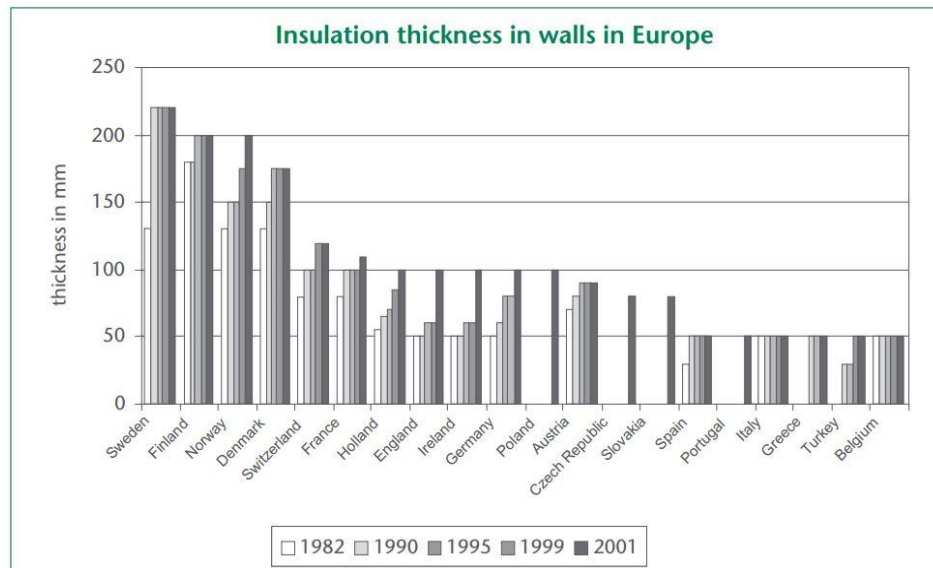

Figure 4. Increase in insulation material thicknesses (standards and / or use) [Eurima 2002]

### 2.2.3 Thermal resistance (R-value) and thermal transmittance (U-Value)

To determine the energy efficiency of a building element we need to take its thermal transmittance ('U-value' [ $\frac{W}{m^2 \cdot K}$ ]) into account. The U-value describes the rate of heat transfer (in watts) through one square metre of a building element divided by the temperature difference (in Kelvin) across this element. A low U-value indicates a well-insulated building element. The U-value is calculated by taking the inverse of the thermal resistance ('R-value' [ $\frac{m^2 \cdot K}{W}$ ]).

$$U = \frac{1}{R}$$

In the National building code of Finland the R-value is defined as followed: "Thermal resistance of a material layer of a uniform thickness or a layered structure in the thermal steady-state indicates the temperature difference between the isothermal surfaces on both sides of the structure divided by the heat flow density through the material layer." (Ministry of the Environment, 2002)

The R-value of a homogeneous layer is expressed as the thickness  $d$  [m] divided by the thermal conductivity  $\lambda$  [ $\frac{W}{m \cdot K}$ ].

$$R = \frac{d}{\lambda} \left[ \frac{m^2 \cdot K}{W} \right]$$

The total thermal resistance  $R_T$  of a building element, consisting of multiple layers, can be calculated by summing all R-values. Here we have to take the external and internal air boundary layer into account ( $R_{se}$  and  $R_{si}$ ). Thereby we obtain the formula for the total U-value:

$$U_T = \frac{1}{R_T} = \frac{1}{R_{se} + \sum_i R_i + R_{si}} \left[ \frac{W}{m^2 * K} \right]$$

To avoid heat losses in a building the U-value should be as low as possible. To achieve this, the level of insulation is of most importance. The lower the thermal conductivity and the higher the thickness of your insulation, the lower the heat loss of a building will be. The recent U-value requirements from the National Building Code of Finland can be obtained from Table 2.

material	thermal conductivity W/mK	thickness required for U=0.13 W/(m <sup>2</sup> K) m
reinforced concrete	2.3	17.30
solid brick	0.80	6.02
perforated brick	0.40	3.01
softwood	0.13	0.98
porous brick, porous concrete	0.11	0.83
<b>straw</b>	<b>0.055</b>	<b>0.41</b>
<b>typical insulation material</b>	<b>0.040</b>	<b>0.30</b>
<b>high-quality conventional insulation material</b>	<b>0.025</b>	<b>0.19</b>
<b>nanoporous super-insulating material normal pressure</b>	<b>0.015</b>	<b>0.11</b>
<b>vacuum insulation material (silica)</b>	<b>0.008</b>	<b>0.06</b>
<b>vacuum insulation material (high vacuum)</b>	<b>0.002</b>	<b>0.015</b>

Figure 5. Material properties required to achieve a U-value of 0.13 W/(m<sup>2</sup>K) (Passive House Institute, 2017)

Figure 5 demonstrates very well how thickness and thermal conductivity of an external building element, consisting only of the material specified, are dependent on each other in order to reach a specific U-value. It shows that a very low U-value of 0.13 W/m<sup>2</sup>K (passive house standard) can be reached, while reducing the thickness of the element to 20cm, by using a common polyurethane foam insulation ('high-quality conventional insulation material').

## 2.3 Moisture

Water can occur in three stages: solid (ice), liquid (water) and gas (water vapour). In vapour and liquid state, water molecules are more mobile than in the solid state. That is why building physics has concentrated mainly on vapour and liquid water transport (Vinha, 2007).

This research will concentrate on the most important kind of moisture transfer, the water vapour diffusion.

### 2.3.1 Moisture performance of walls

The moisture performance of a wall depends on the indoor and outdoor air conditions, the wall assembly solution and the used materials. The best way to achieve a high moisture performance is to prevent moisture from

entering the wall structure as much as possible and to ensure that extra moisture dries out.

“Moisture control has become a worldwide issue because building construction practices have been changing. The need to save energy has resulted in better insulated and airtight envelope systems which can become more sensitive to moisture problems [...]” (Hall, 2010)

Moisture can be dangerous for building materials like insulation, if moisture inside a wall structure is not controlled adequately. The interaction of moisture and building materials may significantly influence the thermal performance of buildings. (Hagentoft, 2011)

Many studies have shown that mould growth in timber-framed walls does occur when the relative humidity is above 80% and the temperature 20°C. EN ISO 13788 (2001) standard states that mould growth in assemblies should be avoided to the highest extent possible.

Concerning allowed condensation and mould growth in external wall assemblies, part C2 of the Finnish Building Code states that if a wall assembly is permeated by a detrimental amount of indoor air water vapour or air, the vapour- or air-tightness of the wall is ensured by installing material layers in the proper places to function as a vapour barrier, an air barrier or sheathing (RakMK C2 1998). Furthermore, the moisture transferring into the external wall by diffusion must not cause damage (RIL 107 2000).

According to German regulations condensation occurring in assemblies is not considered detrimental if the increase in moisture content does not weaken the thermal resistance of building materials and thermal insulations or cause deformations in building materials. These conditions are met when the following is ensured:

- It must be possible for the moisture that has condensed inside the assembly during the wetting period to be able to dry out.
- Condensation must not damage building materials (e.g. through corrosion, mould growth)
- The amount of water condensed in roof and wall assemblies must not exceed 1.0kg/m<sup>2</sup>.
- On surfaces between structural layers made of non-capillary building materials, the total amount of condensed water must not exceed 0.5kg/m<sup>2</sup> (e.g. where mineral wool insulation or an air gap adjoins a vapour barrier or a concrete surface).
- The moisture content of wood must not increase more than 5 wt% and that of wood-based materials no more than 3 wt% during the wetting period. (Deutsches Institut für Normung, 1981)

### 2.3.2 Moisture in air

The water vapour content of air, or the humidity by volume is expressed by  $v$  [kg/m<sup>3</sup>]. Air consists of many gases, which all contribute with its partial pressure to the total air pressure. For water vapour the partial pressure is given by  $p_v$  [Pa]. The empirical equation according to the general gas law

gives the relation between vapour content  $v$  and partial water vapour pressure  $p_v$  [Pa]:

$$p_v = 461.4 * (T + 273.15) * v$$

The temperature  $T$  is given in degrees Celsius.

Figure 6 shows the partial water vapour pressure  $p_v$  as a function of temperature. Vapour saturation pressure follows a more or less exponential curve.

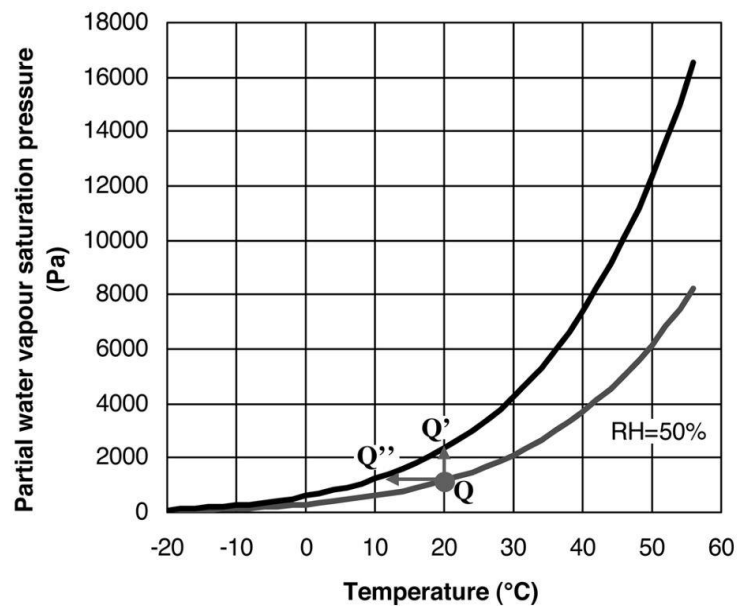

Figure 6. Water vapour saturation pressure at 50% relative humidity (Hens, 2012)

Due to liquid-gas equilibrium for water, there is a maximum possible water vapour content in the air. It will be denoted by  $v_s$  [kg/m<sup>3</sup>]. The humidity by volume at saturation is a function of temperature. For  $v_s$  the following expression can be used:

$$v_s = \frac{a * (b + \frac{T}{100})^n}{461.4 * (T + 273.15)}$$

For  $0 \leq T \leq 30$        $a = 288.68 \text{ Pa}; b = 1.098; n = 8.02$   
 And for  $-20 \leq T \leq 0$        $a = 4.689 \text{ Pa}; b = 1.486; n = 12.2$

Figure 7 presents the function for  $v_s$ , shown above. It shows that humidity by volume at saturation depends on temperature

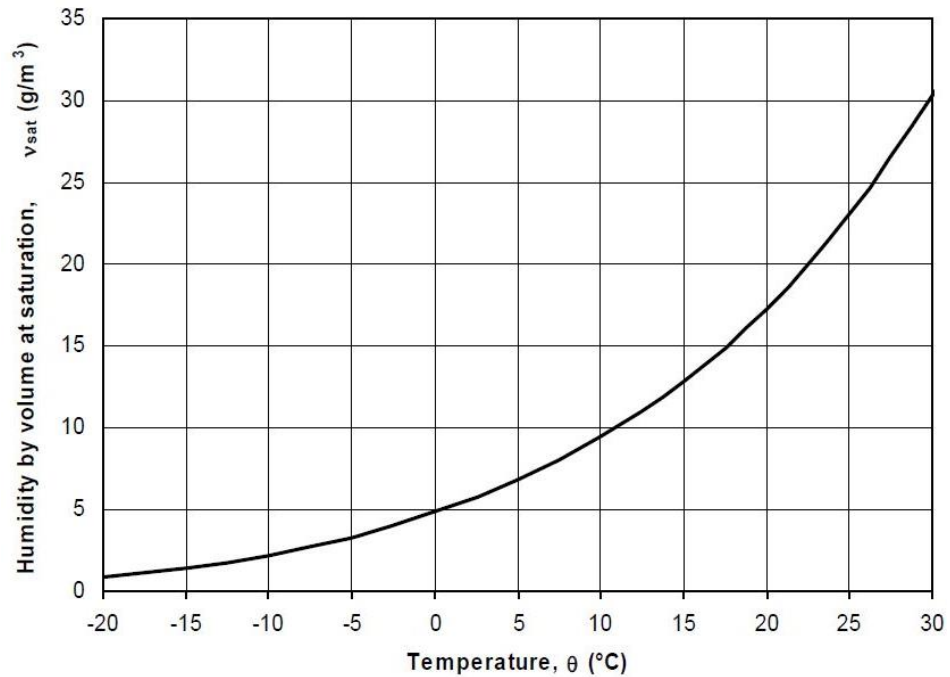

Figure 7. Change in humidity by volume of air at saturation as a function of temperature (DIN 4108-5 1981)

The relative humidity  $\phi$  [%], RH, is defined as:  $\phi = \frac{v}{v_s}$

### 2.3.3 Moisture Transfer (water vapour diffusion)

Inside a building element the water vapour flow is possible in both directions, from the outside-in and the inside-out.

“The amount and direction of flow will be driven by:

- Differences in exterior and interior humidity
- Differences in temperature
- Differences in air pressure created by wind and mechanical systems such as forced air furnaces and large exhaust fans.” (Construction Instruction, 2017)

Water vapour diffusion is the process of water vapour moving through permeable materials caused by differences in water vapour pressure.

Figure 8 shows a layer of porous material like stone wool. The width of the material is  $d$  [m]. The humidity by volume  $v$  is kept at  $v_1$  at one side of the layer and at  $v_2$  on the other side. The steady-state diffusion flux  $g$  [kg/m<sup>2</sup>s] becomes:

$$g = \delta_v * \frac{v_1 - v_2}{d}$$

Here  $\delta_v$  [m<sup>2</sup>/s] is the vapour permeability of the material.

The general expression (Fick’s law) for water vapour diffusion through a material layer is:

$$g = -\delta_v * \frac{dv}{dx}$$

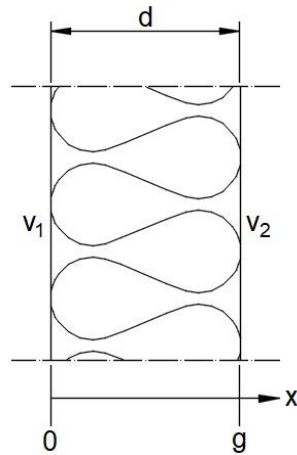

Figure 8. Diffusion of water vapour through a material layer

The rate of diffusion can be compared with the one obtained in stagnant air. The ratio between  $D$  and  $\delta_v$  gives:

$$\mu = \frac{D}{\delta_v}$$

Here  $D$  [ $\text{m}^2/\text{s}$ ] is the Water vapour diffusion coefficient in air.  $D$  varies with temperature. Its empirical equation is:

$$D = 21,2 * 10^{-6} * (1 + 0,0071 * T)$$

Water vapour resistance  $Z_v$  [ $\text{s}/\text{m}$ ] of a single layer is defined as:

$$Z_v = \frac{d}{\delta_v}$$

The diffusion of water vapour through a multi-layered structure under steady-state conditions can be calculated analogous to the way in heat conduction. Therefore the total vapour resistance becomes:

$$Z_{v,tot} = \sum_{i=1}^N \frac{d_i}{\delta_{v,i}} + Z_{vi} + Z_{ve}$$

For the interior and exterior surface vapour resistance the following default values are often used:  $Z_{vi} = 360 \frac{\text{s}}{\text{m}}$  and  $Z_{ve} = 60 \frac{\text{s}}{\text{m}}$  (Hagentoft, 2011).

In case the water vapour permeability  $\delta_p$  [ $\text{kg}/\text{msPa}$ ] is given with respect to partial water vapour pressure Fick's law becomes.

$$g = -\delta_p * \frac{dp_v}{dx}$$

The relations between the permeability values  $\delta_p$  and  $\delta_v$  may be written as:

$$\delta_v = \frac{R * (T + 273.15)}{M} * \delta_p$$

Here R is the Universal gas constant ( $R=8.314 \text{ J}/(\text{mol} * \text{K})$ ) and M is the molar mass of water ( $M=0.01802 \text{ kg}/\text{mol}$ ).

Therefore  $Z_v$  becomes:

$$Z_v = \frac{R * (T + 273.15)}{M} * Z_p$$

### 2.3.4 Moisture transport in Finnish climate

The amount and direction of moisture transport depends mainly on the differences in the humidity by volume on opposite sides of an external wall. Water vapour travels from an area of higher concentration to an area with lower concentration to equalise the humidity differences.

Figure 7 shows that the outside humidity by volume is very low in Finnish winter conditions (e.g.  $-12^\circ\text{C}$ ), even if the RH is high. In general the humidity by volume of indoor air is higher, especially in rooms with higher excess moisture like bathrooms. Therefore diffusion in exterior walls under Finnish climate conditions will almost always cause water vapour flow from the inside-out. To prevent moisture from entering the main insulation layer, an internal vapour barrier is required. Figure 9 shows the basic differences in performance of a timber-framed wall with and without a vapour barrier in Finnish winter conditions.

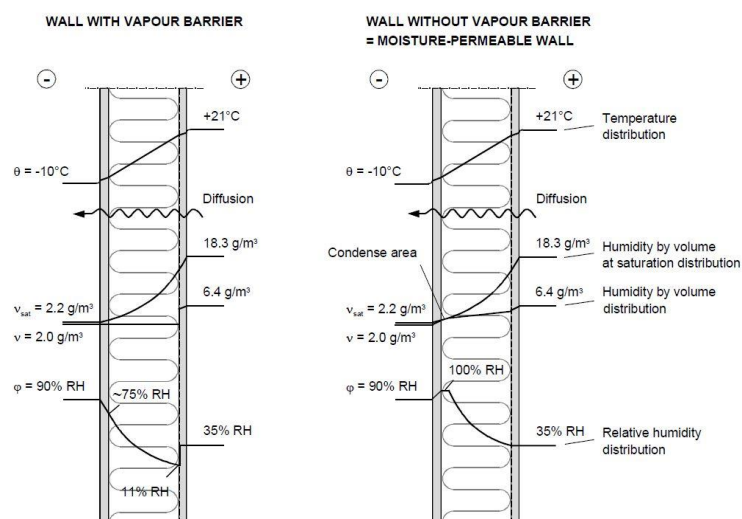

Figure 9. Principle drawing of the differences in with and without vapour barrier in Finnish winter conditions (Vinha, 2007)

When humidity by volume on the interior surface of the vapour barrier reaches humidity by volume at saturation, moisture starts to condensate. According to Vinha (2007, p. 51) in practice, moisture will condense on the



interior surface of the vapour barrier surface since here a RH of 100% is usually reached first.

### 3 METHODOLOGY OF EXPERIMENT

#### 3.1 Wall construction



Figure 10. Wall construction in process

The wall was constructed in the Sheet Metal Centre. The construction plan (Appendix 1) shows all materials that were used with dimensioning and descriptions. As structural elements two timber studs C24 48x198 and two steel C-profiles were used (see Figure 10). For comparison the left steel column is a full C-profile (Ruuki LP-C200) and the right one is a slotted, lightweight thermal C-profile (Ruuki LPT-C200 Termo purlin).

The thermal C-profile should prevent thermal bridging significantly better due to a lower heat flow compared to the full C-profile (see infrared picture (Figure 23)).

As insulation two layers of PAROCeXtra stone wool were used. In the top part between the two insulation layers close to the warm side of the wall a water vapour barrier (Polyethylene sheet) has been placed. It has been placed only in the top part to compare moisture flow with and without a water vapour barrier. To avoid a flow of moisture from the top part to the bottom part of the wall, a horizontal water vapour barrier (SPU-AL100 polyurethane) has been placed along the whole length of the wall.

Due to technical circumstances a polyethylene sheet could not be used as a horizontal water vapour barrier. To increase the water vapour resistance, the thickness of 100mm has been chosen for the polyurethane strip.

The wall has been finished with gypsum boards (GYPROC GEK 13) on both sides.

The internal gypsum boards have been coated with two common waterproofing products (Ardex 8+9 and Kiilto Kerafiber) that are often used in bathrooms and similar wet rooms before tiling.

### 3.2 Waterproofing membranes

For the waterproofing two different products have been used for comparison, Ardex 8+9 and Kiilto Kerafiber.

ARDEX 8+9 is a two-component waterproofing coating that is applied prior to tiling. It consists of an acrylic-based liquid compound and a cement-based powder. The coating protects from topside water infiltration. It has been applied on the left side of the wall (see black surface in Figure 11) with a paint roller.

Kiilto Kerafiber is a ready-mixed, fiber-reinforced waterproofing membrane that is also applied prior to tiling. It has been applied on the right side of the wall, shown as the blue surface in Figure 11.

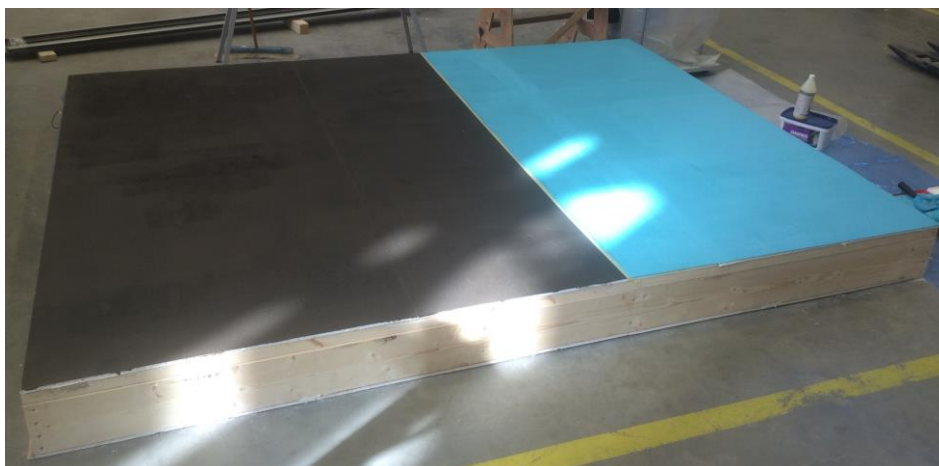

Figure 11. Waterproofing membrane applied on gypsum board (Ardex 8+9 on the left and Kiilto Kerafiber on the right side)

Table 3 shows the water vapour resistance of the two materials. The water vapour resistance of Kiilto Kerafiber is roughly 50% higher than the one of Ardex 8+9.

Table 3. Water vapour resistance of Ardex 8+9 and Kiilto Kerafiber

Material	Zv [s/m]
Ardex 8+9	3.80*10 <sup>4</sup>
Kiilto Kerafiber	5.91*10 <sup>4</sup>

### 3.3 Zones and placement of sensors

For comparison the wall has been divided in four zones. The Sensor and Zones plan (Appendix 1) shows the location of the four zones with dimensioning and descriptions.

In the left two zones the waterproofing product Ardex 8+9 and in the right two zones Kilito Kerafiber has been used. In the top two zones an additional water vapour barrier has been placed on the warm side next to the internal gypsum board.

In each Zone three temperature and relative humidity sensors (RF SensIT) have been placed (see Figure 13). The exact sensor locations can be obtained from the Sensor and Zones plan (Appendix 1) as well. All sensors are connected to sensor boxes that upload the sensor data to a cloud service hourly. The sensors were installed at three different depths to examine the thermal resistance and the water vapour resistance of all the materials in all four zones.

To obtain independent sensor results in every zone they had to be isolated. To avoid vertical moisture transfer from the top zones to the bottom ones a horizontal water barrier has been implemented over the full width of the wall (see Detail B in Wall Construction Plan).

The two timber columns in the middle of the wall structure sufficiently prevent the horizontal transfer of moisture through the wall structure.



Figure 12. Location of Sensors in every Zone



Figure 13. Assembly of Sensors in Zone 1.2

### 3.4 Procedure

The experiment was divided into two stages. The first stage had a duration of 16 days and the second stage had a duration of 7 days (see Table 4):

Table 4. Experiment Stages, duration and conditions

	Duration [d]	Conditions	
		inside (warm)	outside (cold)
Stage 1	16	$\Theta_i \approx 20^\circ\text{C}$	$\Theta_e \approx -12^\circ\text{C}$
		$\Phi_i \approx 80\%$	$\Phi_e \approx 80\%$
Stage 2 (12 holes drilled)	7	$\Theta_i \approx 20^\circ\text{C}$	$\Theta_e \approx -12^\circ\text{C}$
		$\Phi_i \approx 80\%$	$\Phi_e \approx 80\%$

After the wall was connected to the weather simulation chamber, the temperature was set to  $-15^\circ\text{C}$  and the relative humidity was set to 80% to simulate typical Finnish winter conditions. Due to fluctuation of temperature inside the chamber in Table 4 an average of  $-12^\circ\text{C}$  has been assumed. To simulate bathroom conditions on the warm side of the wall a waterproof tent has been built on that side (see Figure 14). A humidifier keeps the relative humidity at 80% and the temperature is the same as inside the Sheet Metal Centre (ca. 80% RH and  $20^\circ\text{C}$ ). These were the conditions for stage 1. The setup is presented in Figure 14.

The conditions for stage 2 were the same as above. In addition 12 holes have been drilled through the warm side of the wall with a  $\varnothing 10$  mm drill bit. The exact locations of the holes can be obtained from the Drilling positions plan (Appendix 1). Holes H1 to H4 were drilled up to a depth of approximately 100mm to penetrate the water vapour barrier (polyethylene sheet) in zone 1.1 and 2.1. The remaining holes H5 to H12 were drilled up to a depth of 30mm to penetrate the waterproofing membrane and gypsum board only. All holes were drilled close to the sensor locations to capture changes in humidity and temperature.



Figure 14. Experiment set-up: waterproof tent with humidifier in the front left, weather simulation chamber in the back, timber frame wall in between

At the end of the second stage samples were taken out of each of the four zones to inspect the insulation material for frost and moisture.

## 4 TEST RESULTS

### 4.1 Stage 1

The first stage of the test was done with the conditions shown in Table 4. This stage was conducted for 16 days. The average temperature and relative humidity (RH) results shown in Table 5 are based on the sensor readings (Appendix 3) retrieved on the final day of stage 1. In addition a manual measurement was done on the same day, shown as M1 and M2 in Table 5, to obtain the missing humidity data on the other side of the Polyethylene sheet (PE-Sheet). In zones 1.1 and 2.1 this was necessary to capture the jump in humidity from the left (cold) to the right (warm) side of the PE-Sheet.

Figure 15 and Figure 16 show four diagrams, one for every zone, generated from Table 5. The Sensor labels (S1-S12, M1 and M2) are shown in grey at the bottom, the temperature profile is shown as a blue line, the RH profile as an orange line and the AH profile as a green line.

Table 5. Stage 1, average sensor results

Average Sensor Results - Stage 1 - 14.04.2017 to 30.04.2017									
Layer	Distance [cm]	Zone 1.1				Zone 2.1			
		Sensors	T [C°]	RH [%]	AH [g/m <sup>3</sup> ]	Sensors	T [C°]	RH [%]	AH [g/m <sup>3</sup> ]
1	1,3	S1*	-11,5	80%	1,55	S7	-11,6	74%	1,40
2	21,3	S2	9,2	22%	1,84	S8	10,2	19%	1,69
2'	21,3	M1**		72%	11,08	M2**		62%	8,49
3	26,3	S3	19,2	59%	9,43	S9	19,1	49%	7,77
Layer	Distance [cm]	Zone 1.2				Zone 2.2			
		Sensors	T [C°]	RH [%]	AH [g/m <sup>3</sup> ]	Sensors	T [C°]	RH [%]	AH [g/m <sup>3</sup> ]
1	1,3	S4*	-11,5	85%	1,71	S10	-11,3	75%	1,44
2	21,3	S5	9,1	28%	2,27	S11	8,7	20%	1,62
2'	21,3								
3	26,3	S6	18,7	17%	2,66	S12	19,0	13%	2,01

\*The data output from sensors S1 and S4 has been incomplete and partly wrong, due to a sensor defect. Data with too much deviation has been removed from the sensor report. Therefore the accuracy of these sensor results is lower.

\*\*The data from sensors M1 and M2 was retrieved manually with a hand-held humidity meter on 24.04. and 28.04.2017. The position of the sensors is on the right side of the vapor barrier. Due to insufficient visibility and space the positioning is not very precise.



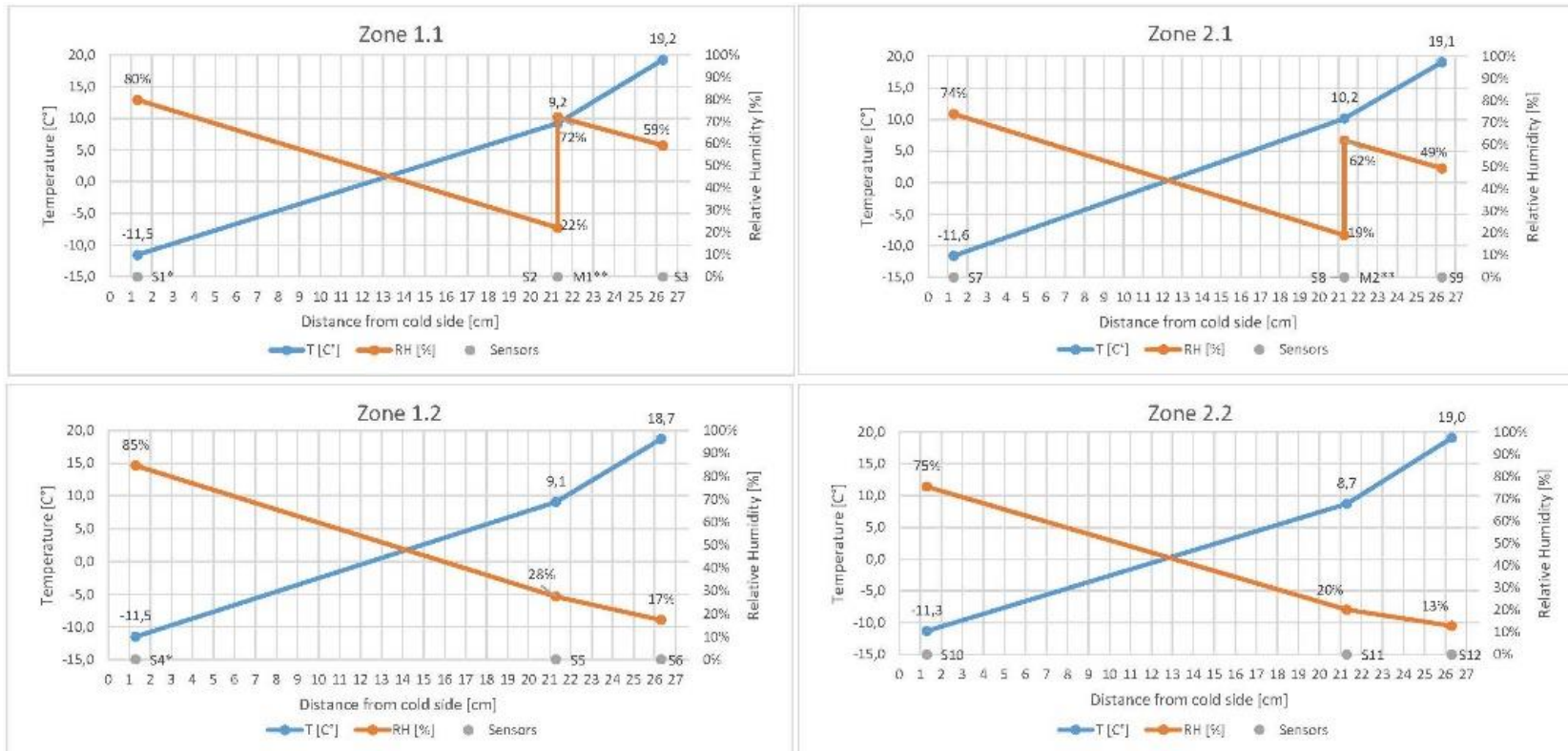

Figure 15. Stage 1, average sensor results, RH diagrams

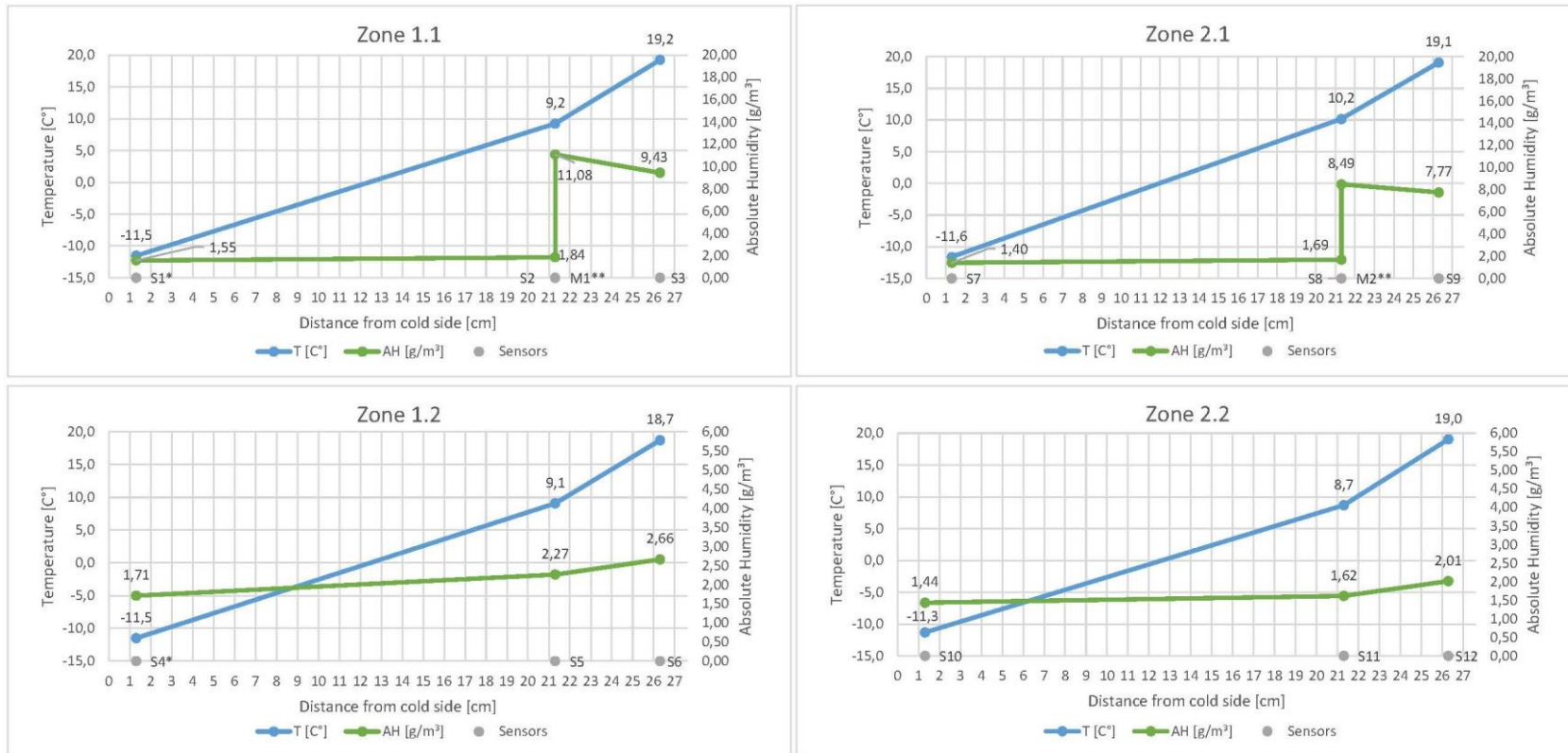

Figure 16. Stage 1, average sensor results, AH diagrams



#### 4.1.1 Temperature

As expected the temperature profile looks similar in every zone. The thermal resistance of an additional PE-Sheet and different waterproofing membranes is negligibly low.

The temperature values close to the cold and the warm side (S1/4/7/10 and S3/6/9/12) are considerably close to the calculated ones (-11.6°C and 19.2°C, see Table 6). The temperature between the two insulation layers was measured lower than calculated (13.2°C) in every zone. Either these sensors (S2/5/8/11) slipped out of position towards the cold side, or the steel profiles with a significantly higher thermal resistance (thermal bridge) effected the sensors more than expected.

Table 6. Calculated temperature gradients for wall section at sensor positions, neglecting influence of timber studs (see Appendix 2)

Exterior	Exterior Surface	Sensors 1/4/7/10	Sensors 2/5/8/11	Sensors 3/6/9/12	Interior Surface	Interior
$\Theta_e$	$\Theta_1$	$\Theta_2$	$\Theta_3$	$\Theta_4$	$\Theta_5$	$\Theta_i$
-12,0°C	-11,8°C	-11,6°C	13,2°C	19,2°C	19,4°C	20,0°C

#### 4.1.2 Moisture

The moisture transfer inside the wall structure was exclusively calculated with the water vapour diffusion method. With the waterproofing membrane and the vapour barrier undamaged, the diffusive water vapour flow going inside the wall structure was expected to be very small.

In Figure 15 the vapour barrier in zones 1.1 and 2.1 is clearly visible as a big drop in humidity. As expected the RH distribution rises from the warm to the cold side, due to diffusive equilibrium.

The calculated values (Table 7) are distinctly higher than the measured AH (see Figure 16). Calculation of moisture flow is very complex, due to many different transport mechanisms. The difference between calculated and measured results is possibly caused by other transport mechanisms than water vapour diffusion. For example capillary flow, convection and gravitational flow were not included in the calculations.

Table 7. Calculated moisture gradients  $v_i$  [g/m<sup>3</sup>] for wall section at sensor positions in zone 1.1 (see Appendix 2)

Exterior	Sensor 1	Sensor 2	Sensor M1	Sensor 3	Interior
$v_e$	$v_1$	$v_2$	$v_3$	$v_4$	$v_i$
1.23	1.25	1.31	13.64	13.65	13.83

## 4.2 Stage 2

For the second stage holes through the waterproofing membrane and the vapour barrier were drilled close to the sensor positions to increase moisture flow from the warm to the cold side.

The temperature profiles (Figure 17) are as expected very similar to the ones from stage 1. The drilled holes did not affect the thermal resistance of the wall relevantly. To show the decreasing thermal resistance of the insulation layers, due to rising humidity, the experiment was not done long enough.

Table 8, Figure 17, Figure 18 were obtained accordingly to the ones in stage 1 in the time frame of stage 2.

Figure 19 and Figure 20 show the linear trend of humidity in every zone. The graphs were obtained by calculating the average humidity on the 08.05.2017 and 14.05.2017 and connecting them linearly. Here the results from the 15.05.2017 were neglected, because the humidifier on the warm side turned itself off on that day. Hence the humidity was not constant on the warm side that day.

Each line in the diagrams represents the results of one sensor. The red line always proceeds accordingly to the sensor on the warm side, the blue line to the sensor on the cold side and the orange line to the sensor in-between.

In all zones the humidity on the cold side stays quite constant. Possibly the timeframe was not long enough for the moisture to penetrate that far into the wall structure. In the top two zones the absolute humidity rises the fastest (from  $9,25\text{g}/\text{m}^3$  to  $11,25\text{g}/\text{m}^3$  in zone 1.1 and from  $7,60\text{g}/\text{m}^3$  to  $10,54\text{g}/\text{m}^3$ ). Here the water vapour coming through the holes stays in this insulation layer. Despite the vapour barrier being penetrated close to the sensors, in this short timeframe it still prevented most of the vapour from passing through. This is also conforming to the sensor results on the other side of the vapour barrier (AH2 and AH8) which are almost constant.

Like expected in the bottom zones the rise in humidity on the warm side is smaller than in the zones above. The reason for that is the higher number of holes in the top zones (see Appendix 1 Drilling Positions).

In the bottom zones the humidity between the insulation layers rises faster because of the missing vapour barrier.

Table 8. Stage 2 , average sensor results

Stage 2 - Average Sensor Results - 08.05.2017 to 15.05.2017									
Layer	Distance [cm]	Zone 1.1				Zone 2.1			
		Sensors	T [C°]	RH [%]	AH [g/m <sup>3</sup> ]	Sensors	T [C°]	RH [%]	AH [g/m <sup>3</sup> ]
1	1,3	S1*	-11,9	88%	1,62	S7	-11,3	87%	1,71
2	21,3	S2	10,1	33%	2,89	S8	10,9	27%	2,48
3	26,3	S3	19,7	64%	10,51	S9	19,6	58%	9,49
Layer	Distance [cm]	Zone 1.2				Zone 2.2			
		Sensors	T [C°]	RH [%]	AH [g/m <sup>3</sup> ]	Sensors	T [C°]	RH [%]	AH [g/m <sup>3</sup> ]
1	1,3	S4*	-11,8	87%	1,65	S10	-11,1	79%	1,53
2	21,3	S5	9,7	30%	2,61	S11	8,9	23%	1,89
3	26,3	S6	19,0	19%	3,01	S12	19,2	15%	2,39

\*The data output from sensors S1 and S4 has been incomplete and partly wrong, due to a sensor defect. Data with too much deviation has been removed from the sensor report. Therefore the accuracy of these sensor results is lower.

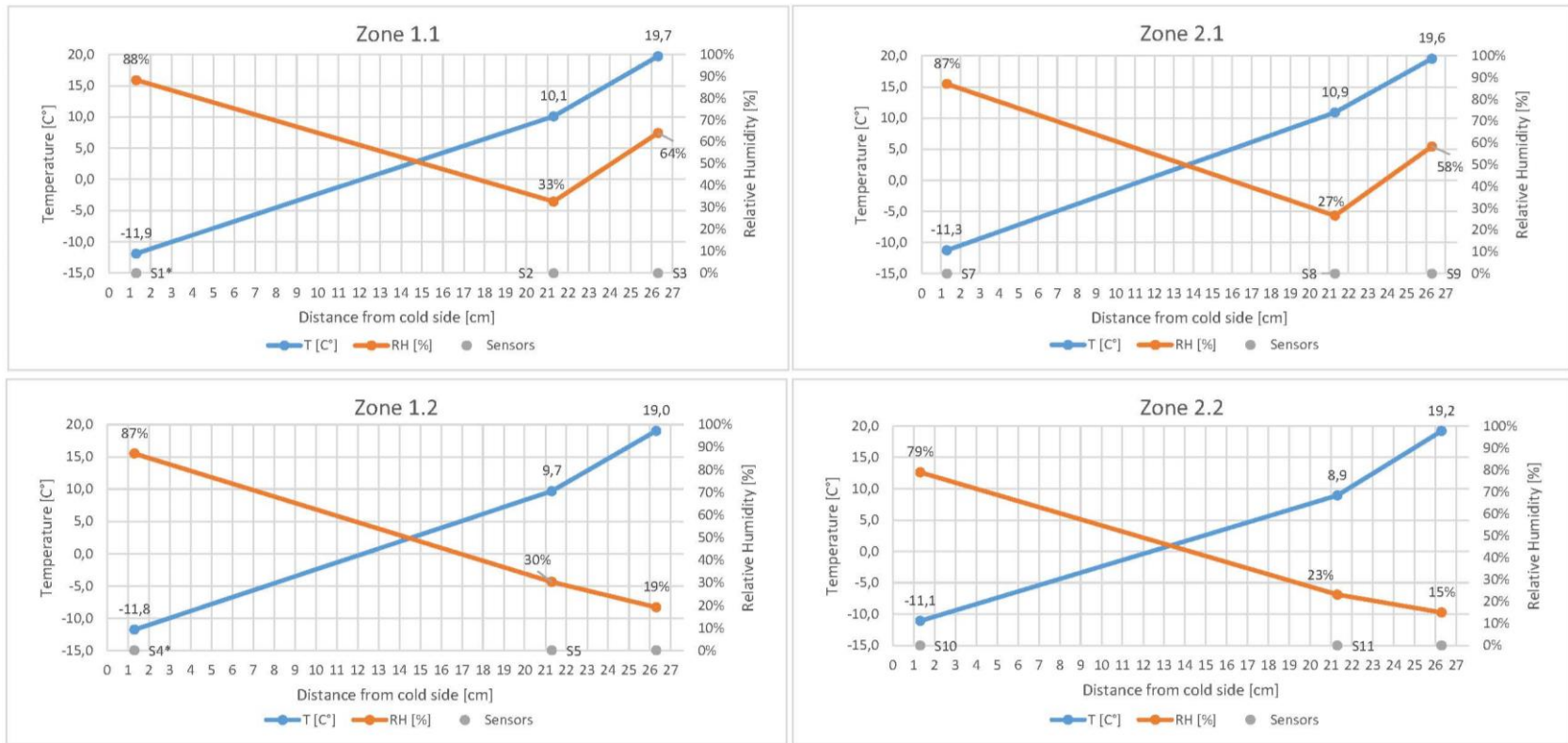

Figure 17. Stage 2, average sensor results, RH diagrams

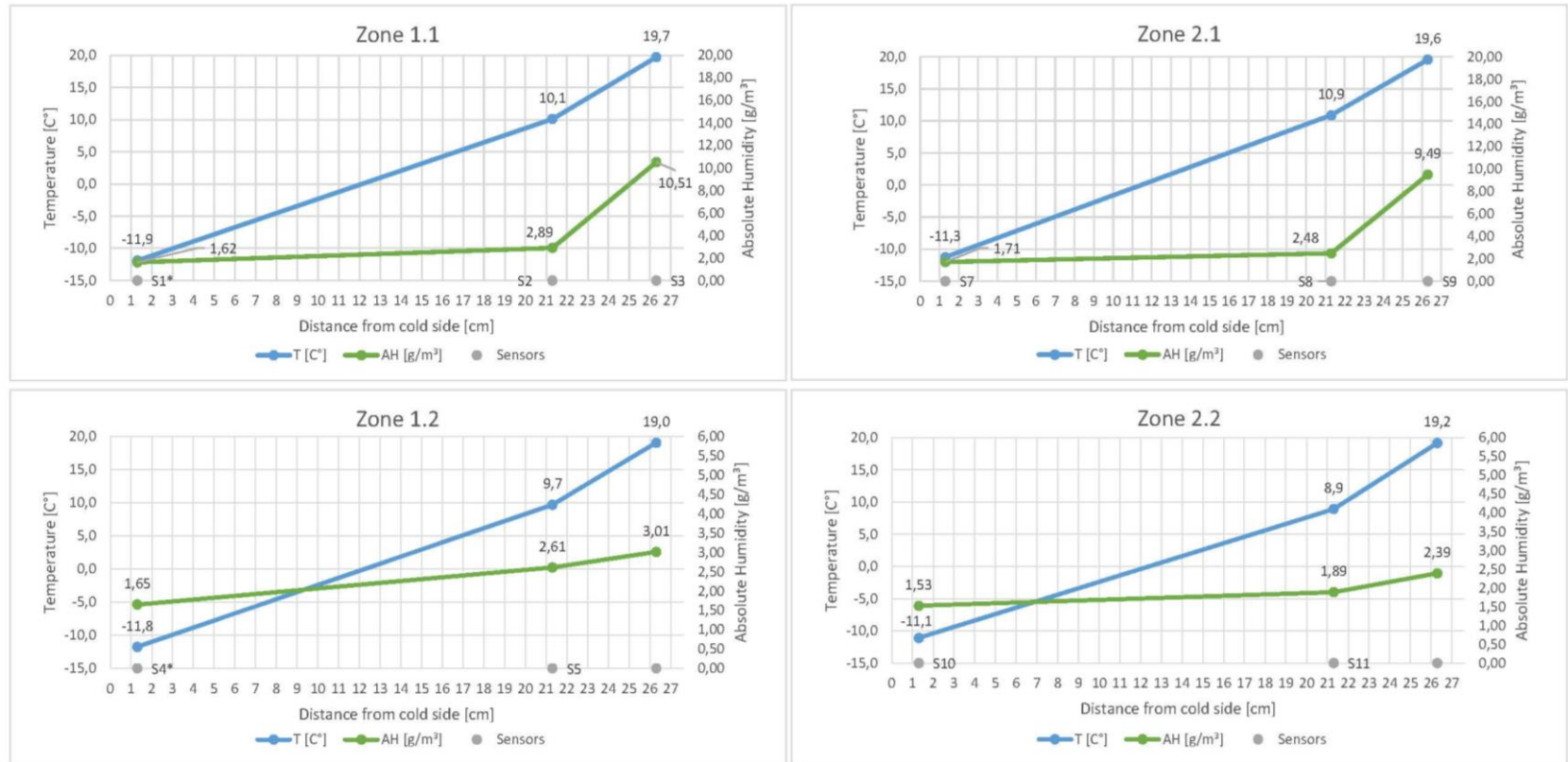

Figure 18. Stage 2, average sensor results, AH diagrams

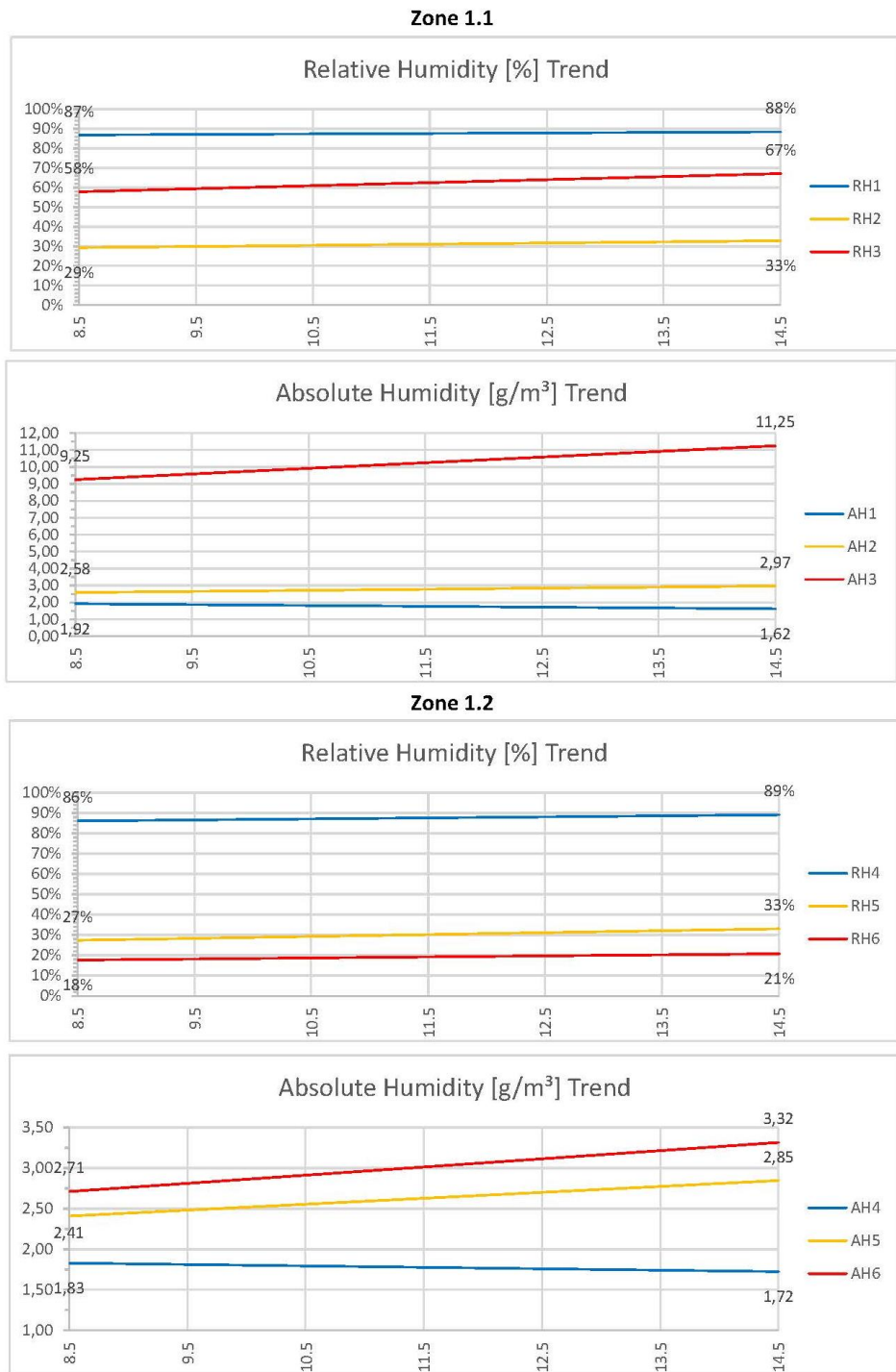

Figure 19. Stage 2, Zone 1.1/1.2, sensor results, linear trend estimation for temperature, RH and AH

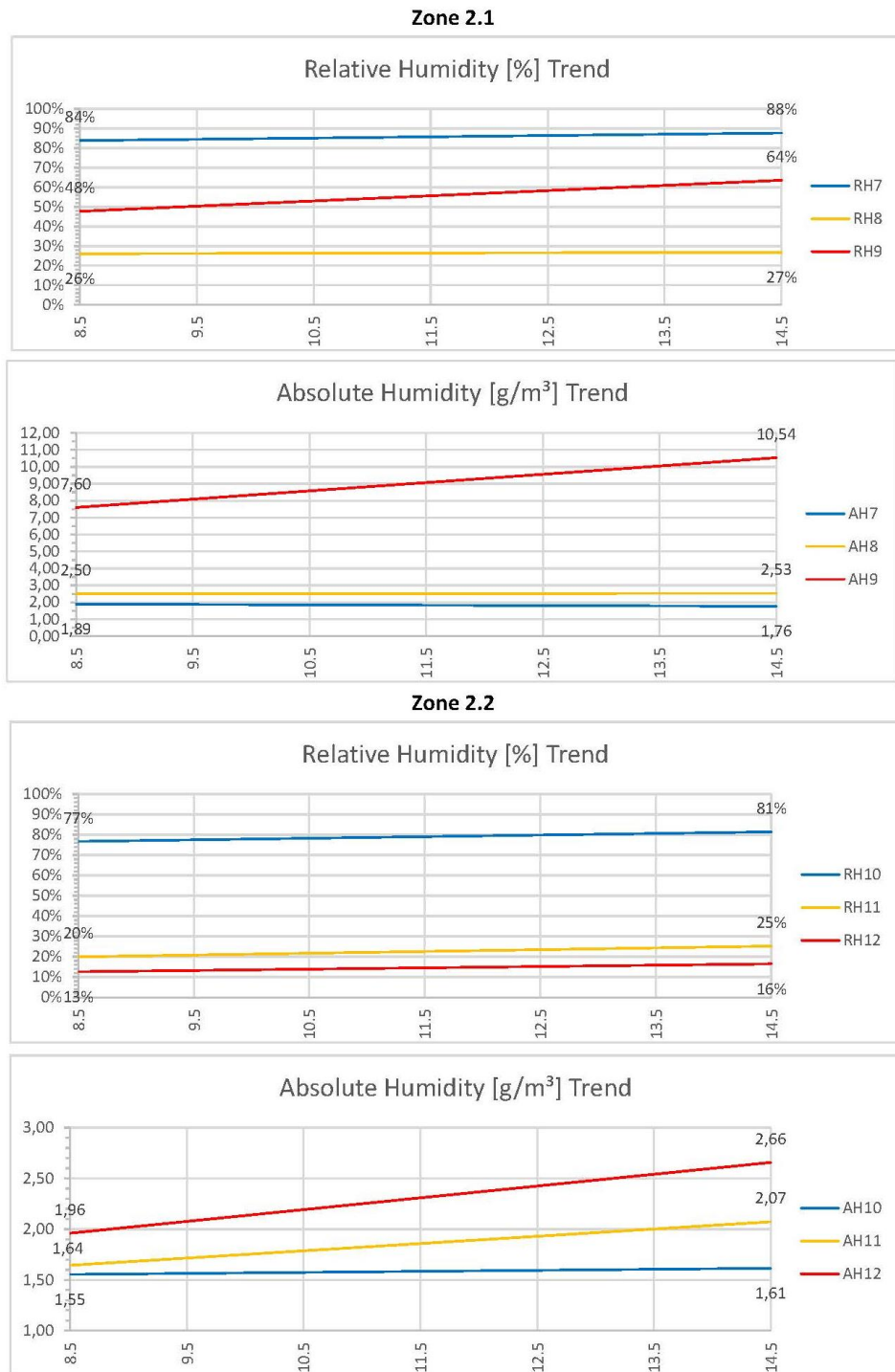

Figure 20. Stage 2, Zone 2.1/2.2, sensor results, linear trend estimation for RH and AH



### 4.3 Examination

At the end of stage 2 the wall was examined in all 4 zones. Sample cylinders ( $\varnothing$  100mm) through both insulation layers were obtained from the wall structure close to the location of the  $\varnothing$  10mm holes in every zone (see Figure 21).

In the top two zones water drops were found on the interior surface of the PE-sheeting. Here water vapour coming from the inside condensed on the colder PE-sheeting surface.

Especially in zones 1.1 and 2.1 the interior insulation layer was tangible wet. This accords with the sensor data of stage 2 (shown in Figure 19 and 0), which show that the humidity inside the interior insulation layer increased strongly in stage 2.

In zones 1.1 and 1.2, where Ardex 8+9 was applied, on the surface of the exterior gypsum board, accumulated frost was clearly visible. In zones 2.1 and 2.2 (Kiilto Kerafiber) that was not the case (see Figure 22).

In zone 1.1 not only the gypsum board surface was frozen, but also a small layer of stone wool close to the surface.

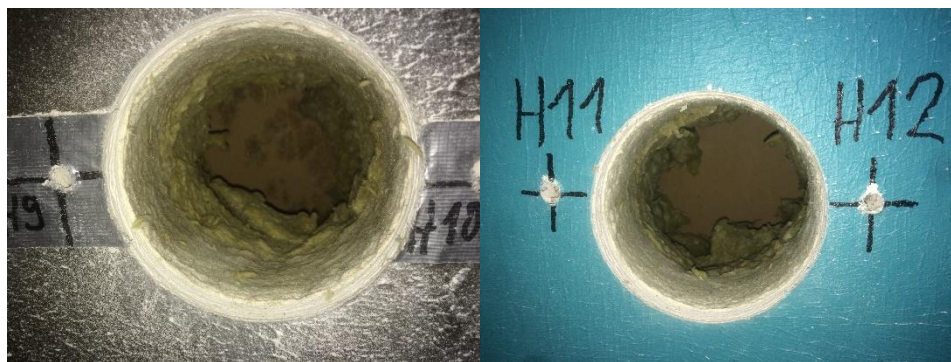

Figure 21. Samples taken from zones 1.2 and 2.2



Figure 22. Ice on surface of exterior gypsum board in zones 1.1 and 1.2



#### 4.4 Thermal Bridges

In the tested wall, timber as well as steel have been used as structural elements. Both have a high thermal conductivity ( $\lambda_{\text{timber}}=0.14\text{W/mK}$  and  $\lambda_{\text{steel}}=16\text{W/mK}$ ) compared to the surrounding materials used, especially compared to the thermal insulation ( $\lambda_{\text{sw}}=0.036\text{W/mK}$ ).

A thermal bridge is defined as an object which has a higher heat transfer than the surrounding materials resulting in an overall reduction in thermal insulation of the building structure (Wikipedia, 2014).

The thermal bridges are clearly visible in the infrared picture (see Figure 23) of the warm side of the wall structure. On the left the non-thermal C-profile (Ruukki LP-C200) is clearly visible as the strongest thermal bridge. The points where the steel-profile meets the horizontal timber studs are the coldest areas of the wall surface, shown in purple (ca.  $17.5^{\circ}\text{C}$ ). Here the steel-profile combined with the timber studs penetrates the whole thermal envelope. In comparison the thermal C-profile (Ruukki LPT-C200) on the right side has an overall lower thermal conductivity. This demonstrates the effectiveness of this C-profile as the thermal resistance is significantly higher. The difference between the two timber beams in the middle and the thermal C-profile on the right is barely visible.

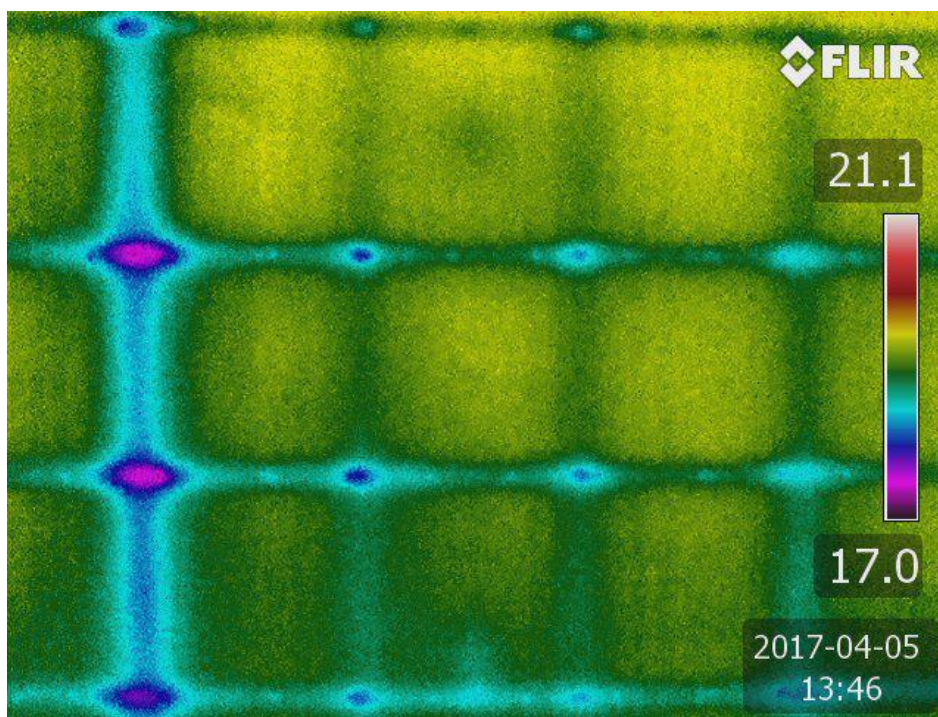

Figure 23. Infrared picture of warm side of the wall before the start of stage 1 (conditions on the cold side were the same as in stage 1)

## 5 CONCLUSION AND DISCUSSION

This study analysed the hygrothermal behaviour of timber-framed exterior walls adjacent to wet rooms exposed to Finnish climatic conditions. It examined the impact of water vapour transported by diffusion from a wet room into the wall structure. An experimental and a calculational analysis were done to compare the results. The results of the calculations do not provide a complete picture of the practical situation since the principles of calculation always need to be simplified in order to keep calculations from becoming too complex. Moreover the actual situation inside the wall structure is never ideal but has defects and weaknesses.

### 5.1 Main results

The main results of this research are the following:

- In Finnish climatic conditions timber-framed external walls can be exposed to a very high level of diffusive vapour transport. Especially in interior rooms with a high humidity, the humidity difference by volume between the inside and the cold outside can become very high, increasing the vapour transport from the inside-out.
- The moisture performance of a timber-framed external wall depends especially on the water vapour resistance of the materials used. The lower resistance of Ardex 8+9 allowed enough water vapour to go through the wall structure and accumulate frost on the cold surface of the exterior gypsum board.

Secondary results are:

- An interior waterproofing membrane functions as a vapour barrier. An additional vapour barrier (PE Sheet) between the insulation layers causes a peak in humidity at that location of the section. Moisture can be trapped between these two vapour barriers and might cause moisture damages to the wall structure in the long term.
- If a vapour barrier inside the wall structure gets too cold, water vapour can condense on its surface. The reason for that could be a too small layer of insulation, wrong placement of the vapour barrier or extremely cold temperatures.
- In case of a localized moisture leak on the inside (e.g. from home appliances), water can easily penetrate into the wall structure, through the interior vapour barrier.

## 5.2 Improvements of experiment

For similar future experiments the following is a list of suggested improvements:

- Extend the length of the experiment to obtain long-term results that show moisture damages and decrease of thermal performance of the wall structure.
- A wall with a smaller exterior insulation layer should be constructed, to see the effects of a colder vapour barrier inside the wall structure.
- More sensors should be used to get more information about the moisture flow inside the wall structure. Especially sensors on both sides of the PE-sheeting would have improved the experiment results.
- Spacers should be used to hold the sensors inside the stone wool in position.
- Air-pressure inside the chamber should be adjustable.
- A chamber on the interior side of the wall structure with adjustable temperature, humidity and air-pressure would make it easier to control inside conditions. The comparability of calculated and measured results could be improved.

## REFERENCES

- Construction Instruction. (2017, 04 28). *constructioninstruction.com*. Retrieved from Air and Vapor Flow: <http://constructioninstruction.com/building-resources/building-science-videos/air-and-vapor-flow/>
- Deutsches Institut für Normung. (1981). DIN 4108-3. In *Wärmeschutz im Hochbau, Klimabedingter Feuchteschutz, Anforderungen und Hinweise für Planung und Ausführung*.
- ECOFYS. (2002). *eurima.org*. Retrieved May 11, 2017, from The Contribution of Mineral Wool and other Thermal Insulation Materials to Energy Saving and Climate Protection in Europe: [http://www.eurima.org/uploads/ModuleXtender/Publications/50/Brochure\\_ecofys\\_final.pdf](http://www.eurima.org/uploads/ModuleXtender/Publications/50/Brochure_ecofys_final.pdf)
- ECOFYS. (2007). *eurima.org*. Retrieved May 11, 2017, from U-VALUES - FOR BETTER ENERGY PERFORMANCE OF BUILDINGS: [http://www.ecofys.com/files/files/ecofys\\_2007\\_uvaluesenergyperformancebuildings.pdf](http://www.ecofys.com/files/files/ecofys_2007_uvaluesenergyperformancebuildings.pdf)
- ePooki. (2015). *OAMK*. Retrieved May 11, 2017, from Sustainable Buildings for the High North: [http://www.oamk.fi/epooki/2015/sustainable-buildings-high-north-energy-performance-technologies-and-challenges-new-buildings-russia-and-scandinavia/?ccm\\_paging\\_p\\_b1802=2#cite-ref-0-7](http://www.oamk.fi/epooki/2015/sustainable-buildings-high-north-energy-performance-technologies-and-challenges-new-buildings-russia-and-scandinavia/?ccm_paging_p_b1802=2#cite-ref-0-7)
- European Commission. (2010, November 10). *2020 Energy Strategy*. Retrieved May 12, 2017, from <https://ec.europa.eu/energy/en/topics/energy-strategy-and-energy-union/2020-energy-strategy>
- European Commission. (2012). *Energy Efficiency - Buildings*. Retrieved May 12, 2017, from <https://ec.europa.eu/energy/en/topics/energy-efficiency/buildings>
- European Commission. (2014, July 23). *2030 Energy Strategy*. Retrieved May 12, 2017, from <https://ec.europa.eu/energy/en/topics/energy-strategy-and-energy-union/2030-energy-strategy>
- Gibson, S. (2010). *Green Building Advisor*. Retrieved May 12, 2017, from <http://www.greenbuildingadvisor.com/blogs/dept/qa-spotlight/can-exterior-foam-insulation-cause-mold-and-moisture-problems>
- Hagentoft, C.-E. (2011). *Introduction to Building Physics*. Lund: Studentlitteratur.
- Hall, M. (2010). *Materials for energy efficiency and thermal comfort in buildings*. Cambridge: Woodhead Publishing Limited.
- Hens, H. (2012). *Building Physics Heat, Air and Moisture*. Leuven: Wilhelm Ernst & Sohn.
- Ministry of the Environment. (2002, October 30). *C4 NATIONAL BUILDING CODE OF FINLAND*. Retrieved from Energy efficiency of buildings: [http://www.ym.fi/en-US/Land\\_use\\_and\\_building/Legislation\\_and\\_instructions/The\\_National\\_Building\\_Code\\_of\\_Finland/Energy\\_efficiency\\_of\\_buildings](http://www.ym.fi/en-US/Land_use_and_building/Legislation_and_instructions/The_National_Building_Code_of_Finland/Energy_efficiency_of_buildings)
- Paroc Group Oy. (2017). *Energy efficiency in buildings*. Retrieved May 12, 2017, from <http://www.paroc.fi/knowhow/energy-efficiency/energy-efficiency-in-buildings>
- Passive House Institute. (2017, April 27). *PASSIPEDIA The Passive House Resource*. Retrieved from Thermal insulation: <https://passipedia.org/planning>
- PU EUROPE. (2008). *PU EUROPE FACTSHEETS*. Retrieved May 12, 2017, from Insulate - Tackling Climate Change Cost-effectively: Implement current legislation with

- ambition: [http://www.pu-europe.eu/index.php?elD=tx\\_nawsecuredl&u=0&g=0&t=1543836964&hash=961a0b94269e86040667f66299beb047ed8386ce&file=fileadmin/documents/Factsheets\\_public/CEPS\\_fs\\_\\_Insulation\\_-\\_public\\_buildings\\_.pdf](http://www.pu-europe.eu/index.php?elD=tx_nawsecuredl&u=0&g=0&t=1543836964&hash=961a0b94269e86040667f66299beb047ed8386ce&file=fileadmin/documents/Factsheets_public/CEPS_fs__Insulation_-_public_buildings_.pdf)
- Rockwool. (2017). *U-Value Calculator*. Retrieved May 11, 2017, from <http://www.rockwool.co.uk/technical-support/tools/U-value-Calculator/>
- Sirviö, A., & Illikainen, K. (2015, December 7). *OAMK*. Retrieved May 11, 2017, from Sustainable Buildings for the High North: [http://www.oamk.fi/epooki/2015/sustainable-buildings-high-north-energy-performance-technologies-and-challenges-new-buildings-russia-and-scandinavia/?ccm\\_paging\\_p\\_b1802=2#cite-text-0-6](http://www.oamk.fi/epooki/2015/sustainable-buildings-high-north-energy-performance-technologies-and-challenges-new-buildings-russia-and-scandinavia/?ccm_paging_p_b1802=2#cite-text-0-6)
- Vaisala. (2013). *HUMIDITY CONVERSION FORMULAS - Calculation formulas for humidity*. Retrieved May 12, 2017, from [http://www.vaisala.fi/Vaisala%20Documents/Application%20notes/Humidity\\_Conversion\\_Formulas\\_B210973EN-F.pdf](http://www.vaisala.fi/Vaisala%20Documents/Application%20notes/Humidity_Conversion_Formulas_B210973EN-F.pdf)
- Vinha, J. (2007). *Hygrothermal Performance of Timber-Framed External Walls in Finnish Climatic Conditions*. Tampere: Tampere University of Technology. Retrieved May 12, 2017, from <https://tutcris.tut.fi/portal/files/1307089/vinha.pdf>
- Wikipedia. (2014). *Thermal bridge*. Retrieved May 12, 2017, from [https://en.wikipedia.org/wiki/Thermal\\_bridge](https://en.wikipedia.org/wiki/Thermal_bridge)

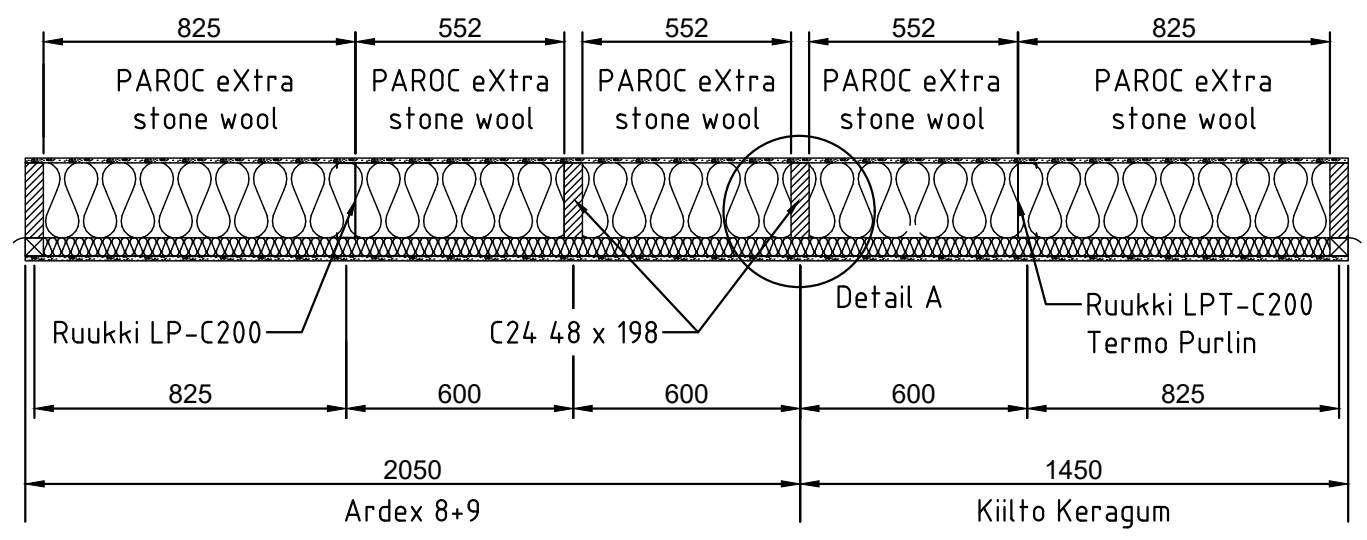

A - A

Detail A 1:5

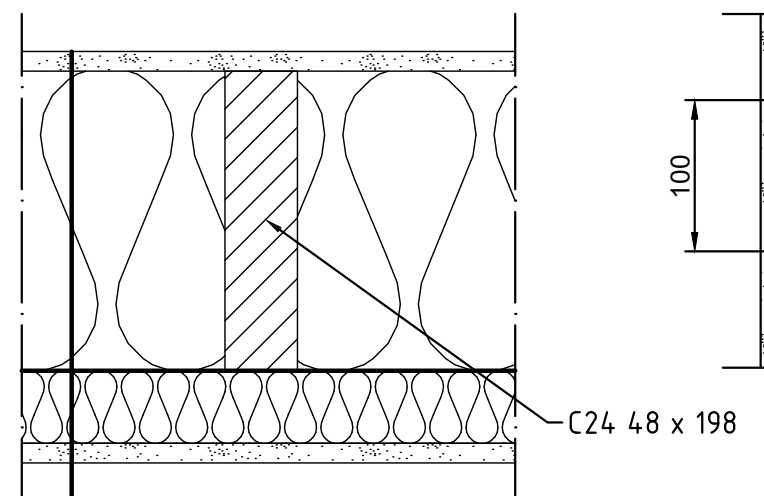

Detail B 1:5

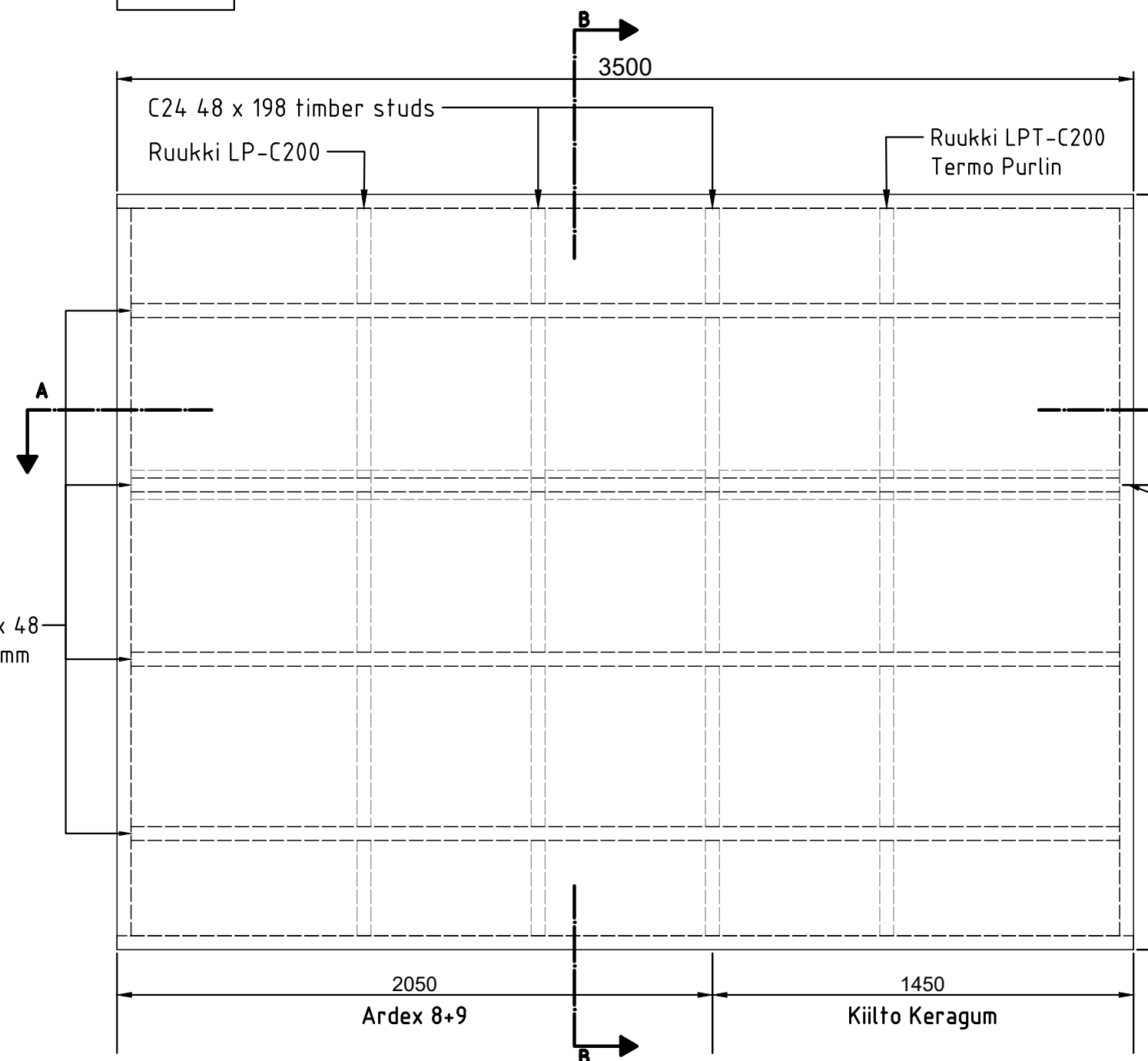
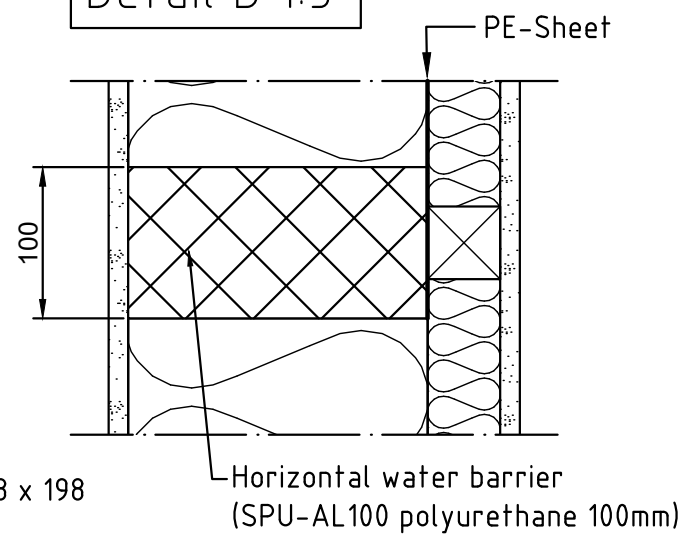

front elevation

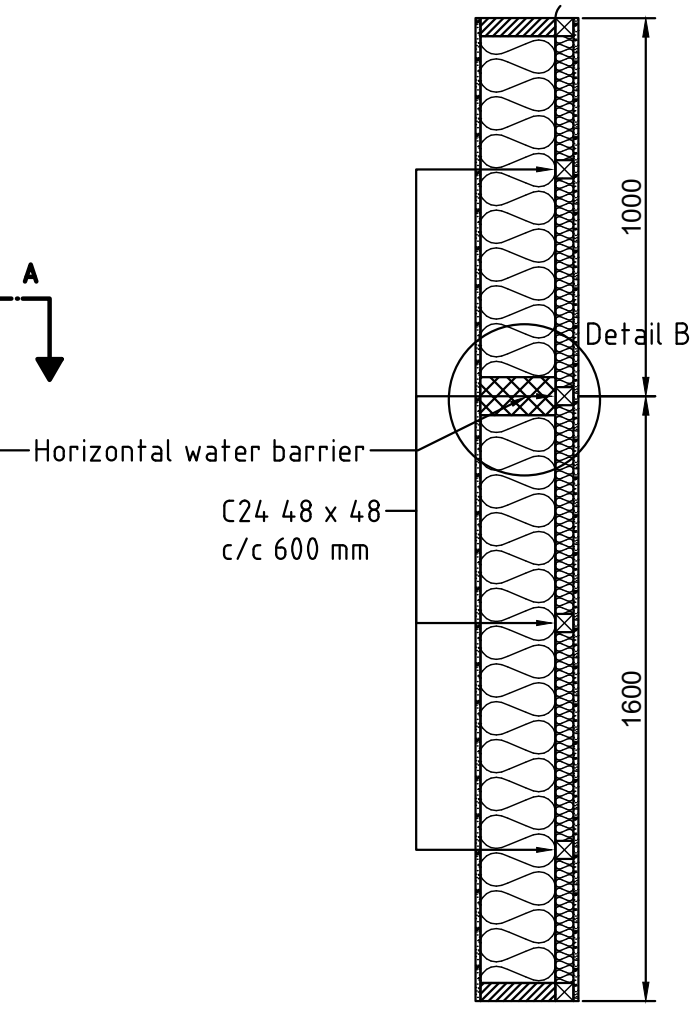

B - B

Jens Kieling
15.05.2017
M. 1:20 mm
Wall Construction

Detail A 1:5  
Sensor Location

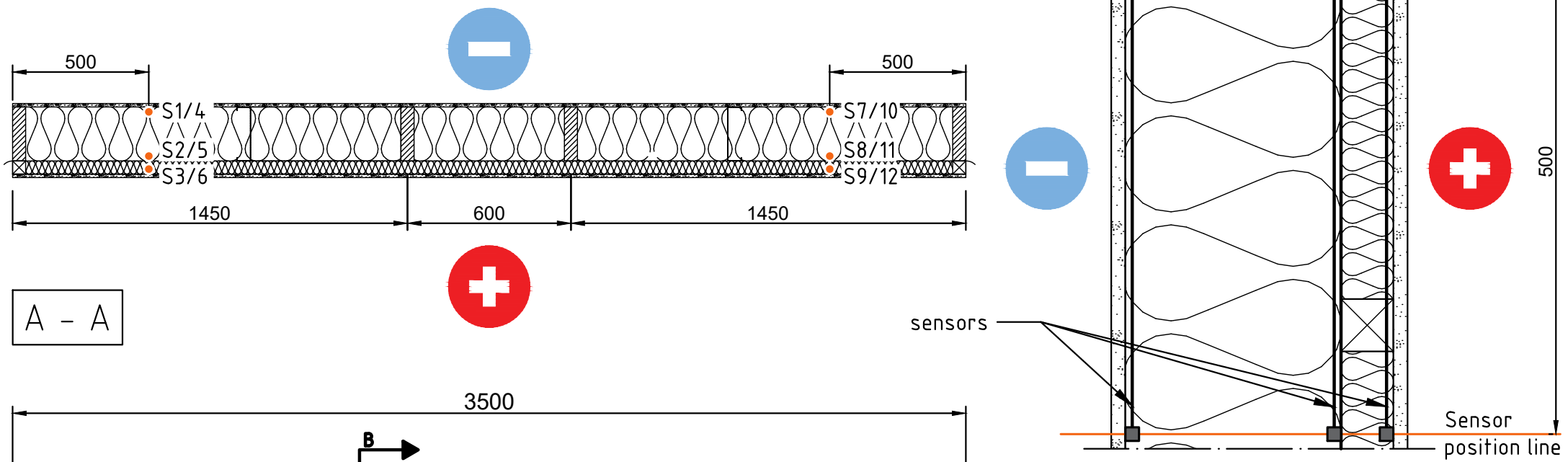

A - A

Detail A

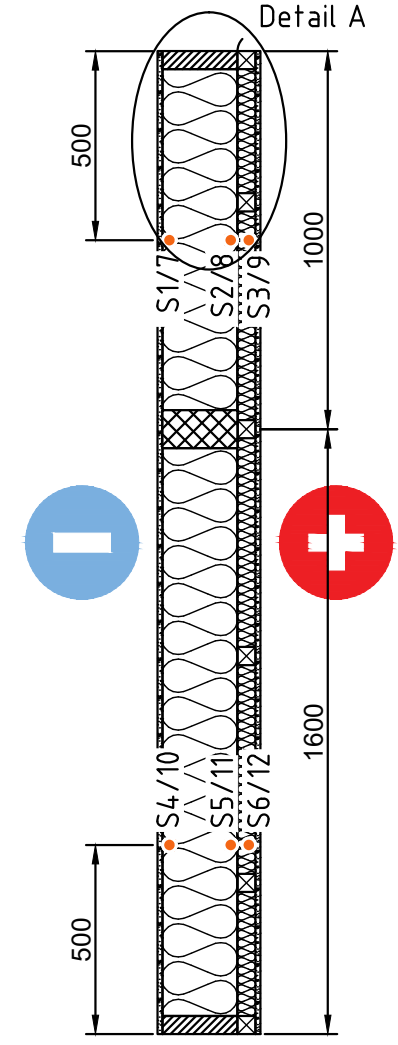

B - B

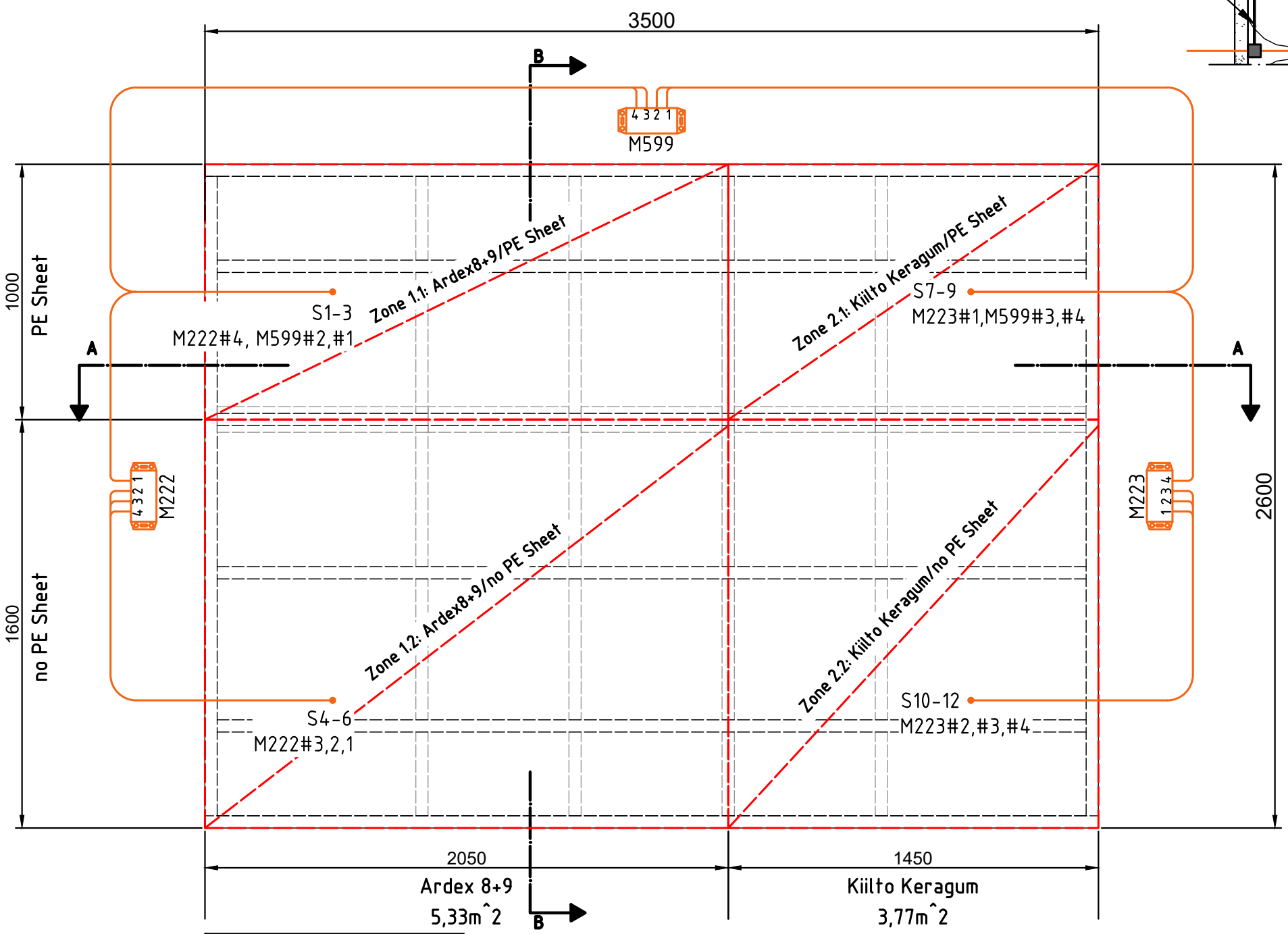

front elevation

Sensor boxes are each connected to 4 sensors

Zone 2.1	M599	1 2 3 4	Zone 1.1
		S3 S2 S9 S8	
Zone 1.1	M222	1 2 3 4	Zone 1.2
		S6 S1 S4 S5	
Zone 2.2	M223	1 2 3 4	Zone 2.1
		S7 S10 S11 S12	

- S1...S12 Temperature + relative humidity sensors
- ▭ Zones

Jens Kieling  
15.05.2017  
M. 1:20 mm  
Sensors and Zones

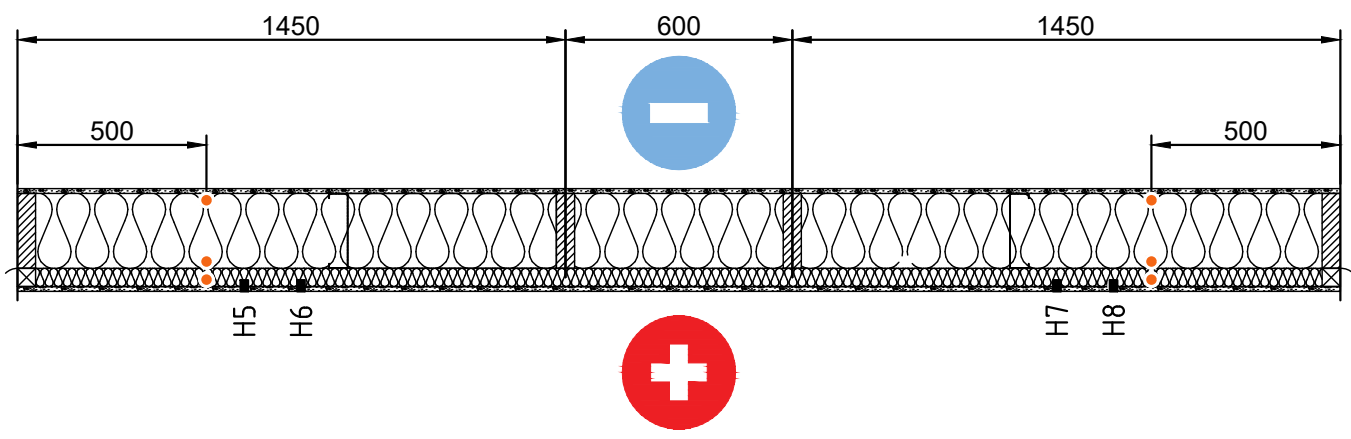

A - A

Detail A 1:5  
Location of holes

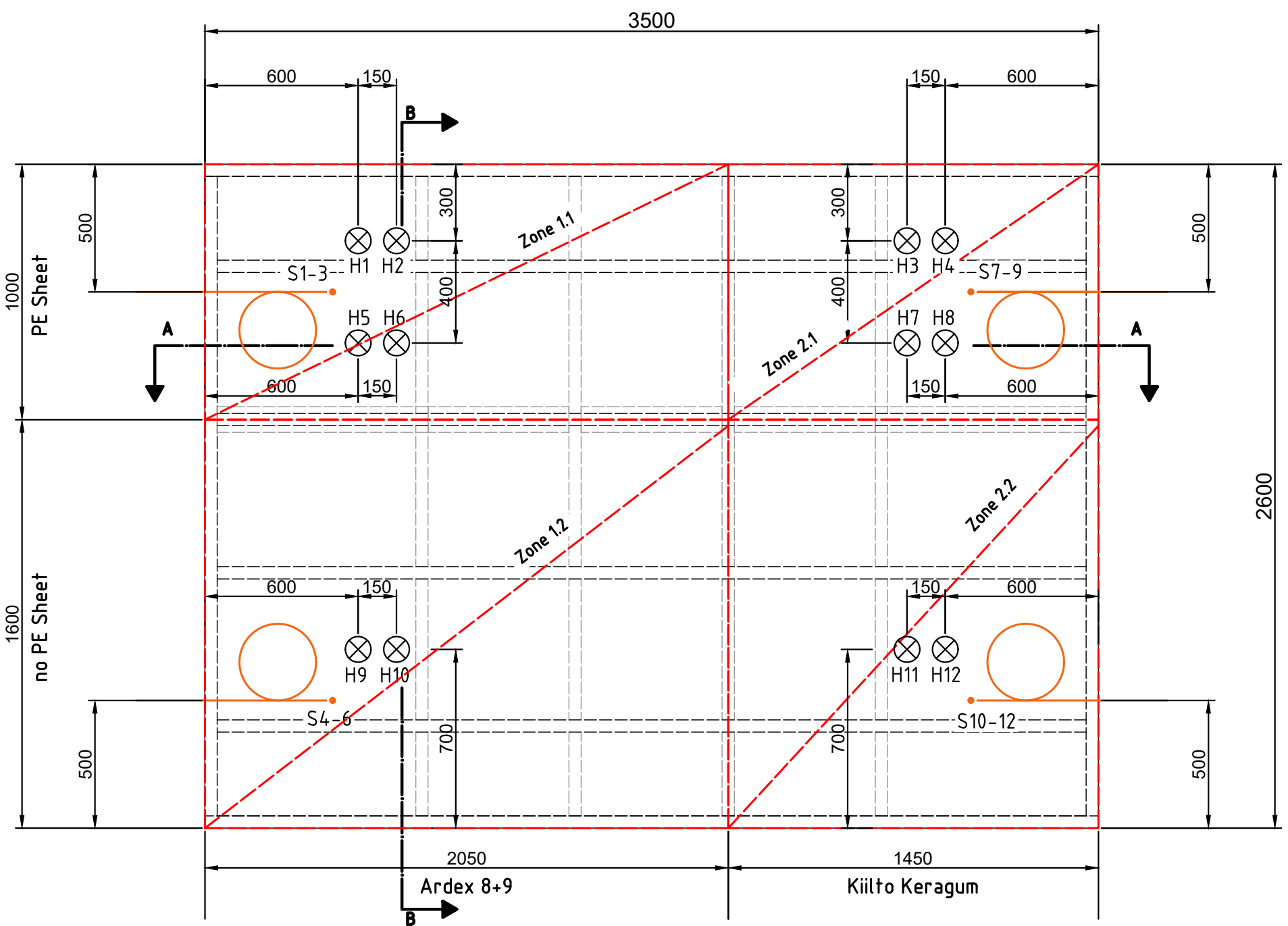
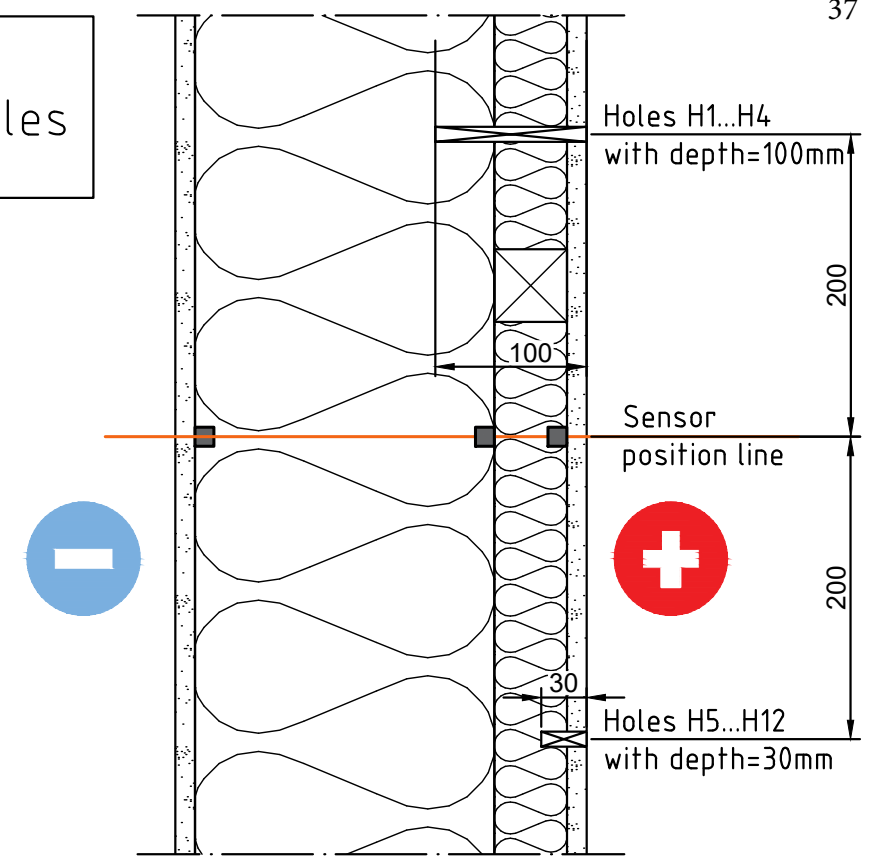

front elevation

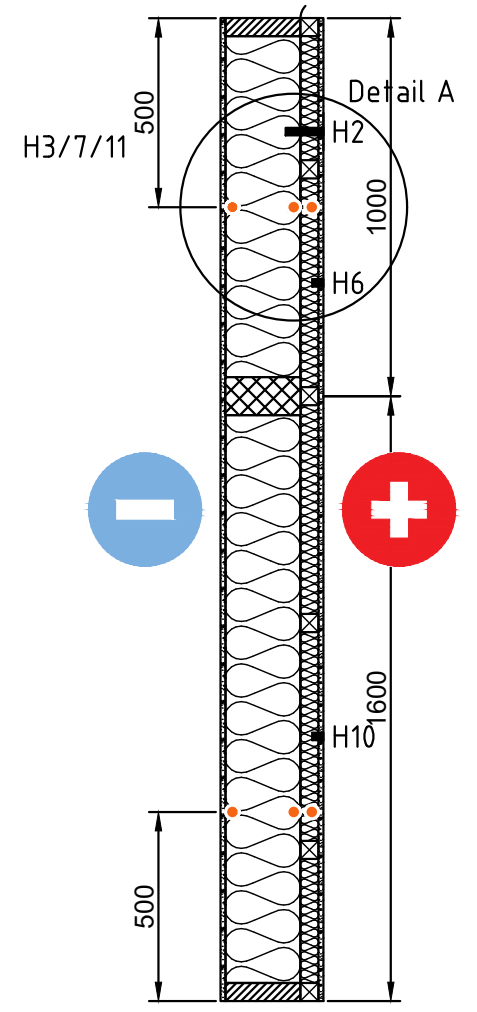

B - B

	S1...S12	Temperature + relative humidity sensors
		Sensor cable
	H1...H4	Holes $\phi$ 10mm depth=100mm
	H5...H12	Holes $\phi$ 10mm depth=30mm
		Zones

Jens Kieling
15.05.2017
M. 1:20 mm
Drilling Positions



## Conductive heat transfer calculation

Thermal conductivities  $\lambda$  [W/m\*K]

$$\lambda_{sw} := 0.036 \frac{W}{m \cdot K} \quad \text{Stone wool}$$

$$\lambda_{gb} := 0.25 \frac{W}{m \cdot K} \quad \text{Gypsum board}$$

$$\lambda_{timber} := 0.14 \frac{W}{m \cdot K} \quad \text{Timber}$$

$$\lambda_{pe} := 0.51 \frac{W}{m \cdot K} \quad \text{PE 0.2mm}$$

Thermal resistances R [m<sup>2</sup>K/W]

$$R_{si} := 0.13 \frac{m^2 \cdot K}{W} \quad \text{Interior air boundary layer}$$

$$R_{se} := 0.04 \frac{m^2 \cdot K}{W} \quad \text{Exterior air boundary layer}$$

$$R_{sw,48} := \frac{0.048 \text{ m}}{\lambda_{sw}} = 1.333 \frac{m^2 \cdot K}{W} \quad \text{Stone wool 50mm}$$

$$R_{sw,198} := \frac{0.198 \text{ m}}{\lambda_{sw}} = 5.5 \frac{m^2 \cdot K}{W} \quad \text{Stone wool 200mm}$$

$$R_{gb} := \frac{0.013 \text{ m}}{\lambda_{gb}} = 0.052 \frac{m^2 \cdot K}{W} \quad \text{Gypsum board 13mm}$$

$$R_{ti,48} := \frac{0.048 \text{ m}}{\lambda_{timber}} = 0.343 \frac{m^2 \cdot K}{W} \quad \text{C24 48x48}$$

$$R_{ti,198} := \frac{0.198 \text{ m}}{\lambda_{timber}} = 1.414 \frac{m^2 \cdot K}{W} \quad \text{C24 48x198}$$

$$R_{pe} := \frac{0.0002 \text{ m}}{\lambda_{pe}} = 0.0004 \frac{m^2 \cdot K}{W} \quad \text{PE 0.2mm vapour barrier (insignificant)}$$

### Average R- and U-values for inhomogeneous sections

$$A := 0.6 \text{ m} \cdot 1.0 \text{ m} = 0.6 \text{ m}^2$$

$$A_a := 0.048 \text{ m} \cdot 1.0 \text{ m} = 0.048 \text{ m}^2$$

$$A_b := (0.6 \text{ m} - 0.048 \text{ m}) \cdot 1.0 \text{ m} = 0.552 \text{ m}^2$$

#### Layer 1 (13mm gb + 48mm sw / C24 48x48 + PE)

Upper limit:

$$R_{1,u;a} := R_{gb} + R_{ti;48} = 0.395 \frac{\text{m}^2 \cdot \text{K}}{\text{W}}$$

$$R_{1,u;b} := R_{gb} + R_{sw;48} = 1.385 \frac{\text{m}^2 \cdot \text{K}}{\text{W}}$$

$$R_{1,u} := \frac{A}{\frac{A_a}{R_{1,u;a}} + \frac{A_b}{R_{1,u;b}}} = 1.154 \frac{\text{m}^2 \cdot \text{K}}{\text{W}}$$

$$R_{1,tot} := \frac{R_{1,u} + 2 \cdot R_{1,l}}{3} = 1.141 \frac{\text{m}^2 \cdot \text{K}}{\text{W}}$$

Lower limit:

$$R_{1,l;inhom} := \frac{A}{\frac{A_a}{R_{ti;48}} + \frac{A_b}{R_{sw;48}}} = 1.083 \frac{\text{m}^2 \cdot \text{K}}{\text{W}}$$

$$R_{1,l} := R_{gb} + R_{1,l;inhom} = 1.135 \frac{\text{m}^2 \cdot \text{K}}{\text{W}}$$

#### Layer 1 + 198mm stone wool / timber stud C24 48x198 + 13mm gb

Upper limit:

$$R_{u;a} := R_{si} + R_{1,tot} + R_{ti;198} + R_{gb} + R_{se} = 2.778 \frac{\text{m}^2 \cdot \text{K}}{\text{W}}$$

$$R_{u;b} := R_{si} + R_{1,tot} + R_{sw;198} + R_{gb} + R_{se} = 6.863 \frac{\text{m}^2 \cdot \text{K}}{\text{W}}$$

$$R_u := \frac{A}{\frac{A_a}{R_{u;a}} + \frac{A_b}{R_{u;b}}} = 6.141 \frac{\text{m}^2 \cdot \text{K}}{\text{W}}$$

$$R_{tot} := \frac{R_u + 2 \cdot R_l}{3} = 5.934 \frac{\text{m}^2 \cdot \text{K}}{\text{W}}$$

$$U_{tot} := \frac{1}{R_{tot}} = 0.169 \frac{\text{W}}{\text{m}^2 \cdot \text{K}}$$

Lower limit:

$$R_{l;inhom} := \frac{A}{\frac{A_a}{R_{ti;198}} + \frac{A_b}{R_{sw;198}}} = 4.468 \frac{\text{m}^2 \cdot \text{K}}{\text{W}}$$

$$R_l := R_{si} + R_{1,tot} + R_{l;inhom} + R_{gb} + R_{se} = 5.831 \frac{\text{m}^2 \cdot \text{K}}{\text{W}}$$

### Surface temperatures

To increase comparability with sensor results, the influence of the timber studs was neglected.

$$R_{sw} := R_{si} + R_{gb} + R_{sw;48} + R_{sw;198} + R_{gb} + R_{se} = 7.107 \frac{m^2 \cdot K}{W}$$

$$U_{sw} := \frac{1}{R_{sw}} = 0.141 \frac{W}{m^2 \cdot K}$$

Boundary Conditions

$$\Theta_i := 20 \text{ } ^\circ\text{C} = 293.15 \text{ } K$$

$$\Theta_e := -12 \text{ } ^\circ\text{C} = 261.15 \text{ } K$$

$$\Delta\Theta := \Theta_i - \Theta_e = 32 \text{ } K$$

Temperature gradients

$$\Theta_0 := \Theta_e = -12 \text{ } ^\circ\text{C}$$

$\Theta_i$  exterior temperature

$$\Theta_1 := \Theta_0 + \frac{R_{se}}{R_{sw}} \cdot (\Delta\Theta) = -11.82 \text{ } ^\circ\text{C}$$

exterior surface temperature

$$\Theta_2 := \Theta_1 + \frac{R_{gb}}{R_{sw}} \cdot (\Delta\Theta) = -11.586 \text{ } ^\circ\text{C}$$

compare Sensors 1/4/7/10

$$\Theta_3 := \Theta_2 + \frac{R_{sw;198}}{R_{sw}} \cdot (\Delta\Theta) = 13.177 \text{ } ^\circ\text{C}$$

compare Sensors 2/5/8/11

$$\Theta_4 := \Theta_3 + \frac{R_{sw;48}}{R_{sw}} \cdot (\Delta\Theta) = 19.181 \text{ } ^\circ\text{C}$$

compare Sensors 3/6/9/12

$$\Theta_5 := \Theta_4 + \frac{R_{gb}}{R_{sw}} \cdot (\Delta\Theta) = 19.415 \text{ } ^\circ\text{C}$$

interior surface temperature

$$\Theta_6 := \Theta_5 + \frac{R_{si}}{R_{sw}} \cdot (\Delta\Theta) = 20 \text{ } ^\circ\text{C}$$

$\Theta_e$  interior temperature

## Water vapour diffusion calculation

General Parameter

$$R := 8.314 \frac{J}{mol \cdot K} \quad \text{Universal gas constant}$$

$$M := 0.01802 \frac{kg}{mol} \quad \text{Molar mass of water}$$

Water vapour permeabilities with respect to partial vapour pressure

$$\delta_{p;sw} := 1.05 \cdot 10^{-10} \frac{kg}{m \cdot s \cdot Pa} = (1.05 \cdot 10^{-10}) s \quad \text{Stone wool}$$

$$\delta_{p;gb} := 2.0 \cdot 10^{-11} \frac{kg}{m \cdot s \cdot Pa} = (2 \cdot 10^{-11}) s \quad \text{GYPROC GEK 13 gypsum board}$$

$$\delta_{p;pe} := 5.0 \cdot 10^{-16} \frac{kg}{m \cdot s \cdot Pa} = (5 \cdot 10^{-16}) s \quad \text{PE 0.2mm}$$

Water vapour resistances (with respect to partial vapour pressure):

$$Z_{p;sw;50} := \frac{0.050 m}{\delta_{p;sw}} = (4.762 \cdot 10^8) \frac{m}{s} \quad \text{Stone wool 50mm}$$

$$Z_{p;sw;200} := \frac{0.200 m}{\delta_{p;sw}} = (1.905 \cdot 10^9) \frac{m}{s} \quad \text{Stone wool 200mm}$$

$$Z_{p;ardex} := \frac{R \cdot \Theta_5}{M} \cdot 38.0 \cdot 10^3 \frac{s}{m} = (5.129 \cdot 10^9) \frac{m}{s} \quad \text{Ardex 8+9 0,8mm (conversion based on Vinha, J. (2007):37)}$$

$$Z_{p;kiilto} := \frac{R \cdot \Theta_5}{M} \cdot 59.1 \cdot 10^3 \frac{s}{m} = (7.977 \cdot 10^9) \frac{m}{s} \quad \text{Kiilto Keragum 0,4mm (conversion based on Vinha, J. (2007):37)}$$

$$Z_{p;gb} := \frac{0.013 m}{\delta_{p;gb}} = (6.5 \cdot 10^8) \frac{m}{s} \quad \text{GYPROC GEK 13 gypsum board 13mm}$$

$$Z_{p;pe} := \frac{0.0002 m}{\delta_{p;pe}} = (4 \cdot 10^{11}) \frac{m}{s} \quad \text{PE 0.2mm}$$

Boundary Conditions (interior and exterior moisture in air)

$$\phi_i := 80\% \quad \phi_e := 80\% \quad \text{interior/ exterior relative humidity}$$

$$\Theta_i := 20 \text{ }^\circ\text{C} \quad \Theta_e := -12 \text{ }^\circ\text{C} \quad \text{interior/ exterior temperature}$$

$$\theta_i := \frac{\Theta_i}{K} - 273.15 = 20 \quad \theta_e := \frac{\Theta_e}{K} - 273.15 = -12 \quad \text{interior/ exterior temperature (no unit)}$$

$$\nu_{s;i} := \frac{288.68 \cdot \left(1.098 + \frac{\theta_i}{100}\right)^{8.02}}{461.4 \cdot (\theta_i + 273.15)} \cdot 10^3 \frac{gm}{m^3} = 17.287 \frac{gm}{m^3} \quad \text{interior humidity by volume at saturation}$$

$$\nu_{s;e} := \frac{4.689 \cdot \left(1.468 + \frac{\theta_e}{100}\right)^{12.3}}{461.4 \cdot (\theta_e + 273.15)} \cdot 10^3 \frac{gm}{m^3} = 1.532 \frac{gm}{m^3} \quad \text{exterior humidity by volume at saturation}$$

$$\nu_i := \nu_{s;i} \cdot \phi_i = 13.829 \frac{gm}{m^3} \quad \nu_e := \nu_{s;e} \cdot \phi_e = 1.226 \frac{gm}{m^3} \quad \text{interior/ exterior vapour content by volume}$$

$$p_{vi} := 461.4 \cdot \frac{\Theta_i}{K} \cdot \frac{\nu_i}{\frac{gm}{m^3}} \cdot 10^{-3} Pa = (1.871 \cdot 10^3) Pa \quad \text{interior partial vapour pressure}$$

$$p_{ve} := 461.4 \cdot \frac{\Theta_e}{K} \cdot \frac{\nu_e}{\frac{gm}{m^3}} \cdot 10^{-3} Pa = 147.692 Pa \quad \text{exterior partial vapour pressure}$$

Calculations according to Hagentoft (2001):88 ff.

$$Z_{vi} := 360 \frac{s}{m} \quad Z_{ve} := 60 \frac{s}{m} \quad \text{Default values for surface vapor resistance according to Hagentoft (2001):107}$$

$$Z_{p;i} := \frac{R \cdot \Theta_i}{M} \cdot Z_{vi} = (4.869 \cdot 10^7) \frac{m}{s} \quad \text{interior surface vapour resistance}$$

$$Z_{p;e} := \frac{R \cdot \Theta_e}{M} \cdot Z_{ve} = (7.229 \cdot 10^6) \frac{m}{s} \quad \text{exterior surface vapour resistances}$$

Conversion according to Vinha, J. (2007):37

## Stage 1

### Expected water vapour net flow

Ardex 8+9 with PE (Zone 1.1)

$$Z_{p;tot;ardex;pe} := Z_{p;i} + Z_{p;ardex} + Z_{p;gb} + Z_{p;sw;50} + Z_{p;pe} + Z_{p;sw;200} + Z_{p;gb} + Z_{p;e} = (4.089 \cdot 10^{11}) \frac{m}{s}$$

$$g_{ardex;pe} := \frac{p_{vi} - p_{ve}}{Z_{p;tot;ardex;pe}} = (4.214 \cdot 10^{-9}) \frac{kg}{m^2 \cdot s}$$

Ardex 8+9 without PE (Zone 1.2)

$$Z_{p;tot;ardex} := Z_{p;i} + Z_{p;ardex} + Z_{p;gb} + Z_{p;sw;50} + Z_{p;sw;200} + Z_{p;gb} + Z_{p;e} = (8.866 \cdot 10^9) \frac{m}{s}$$

$$g_{ardex} := \frac{p_{vi} - p_{ve}}{Z_{p;tot;ardex}} = (1.943 \cdot 10^{-7}) \frac{kg}{m^2 \cdot s}$$

Kiilto Keragum with PE (Zone 2.1)

$$Z_{p;tot;kiilto;pe} := Z_{p;i} + Z_{p;kiilto} + Z_{p;gb} + Z_{p;sw;50} + Z_{p;pe} + Z_{p;sw;200} + Z_{p;gb} + Z_{p;e} = (4.117 \cdot 10^{11}) \frac{m}{s}$$

$$g_{kiilto;pe} := \frac{p_{vi} - p_{ve}}{Z_{p;tot;kiilto;pe}} = (4.185 \cdot 10^{-9}) \frac{kg}{m^2 \cdot s}$$

Kiilto Keragum without PE (Zone 2.2)

$$Z_{p;tot;kiilto} := Z_{p;i} + Z_{p;kiilto} + Z_{p;gb} + Z_{p;sw;50} + Z_{p;sw;200} + Z_{p;gb} + Z_{p;e} = (1.171 \cdot 10^{10}) \frac{m}{s}$$

$$g_{kiilto} := \frac{p_{vi} - p_{ve}}{Z_{p;tot;kiilto}} = (1.471 \cdot 10^{-7}) \frac{kg}{m^2 \cdot s}$$

**Moisture gradients (assuming steady-state conditions)**

Ardex 8+9 with PE (Zone 1.1)

$$\nu_1 := \nu_e + \frac{Z_{p;e} + Z_{p;gb}}{Z_{p;tot;ardex;pe}} \cdot (\nu_i - \nu_e) = 1.246 \frac{gm}{m^3}$$

$$\nu_2 := \nu_e + \frac{Z_{p;e} + Z_{p;gb} + Z_{p;sw;200}}{Z_{p;tot;ardex;pe}} \cdot (\nu_i - \nu_e) = 1.305 \frac{gm}{m^3}$$

$$\nu_3 := \nu_e + \frac{Z_{p;e} + Z_{p;gb} + Z_{p;sw;200} + Z_{p;pe}}{Z_{p;tot;ardex;pe}} \cdot (\nu_i - \nu_e) = 13.635 \frac{gm}{m^3}$$

$$\nu_4 := \nu_e + \frac{Z_{p;e} + Z_{p;gb} + Z_{p;sw;200} + Z_{p;pe} + Z_{p;sw;50}}{Z_{p;tot;ardex;pe}} \cdot (\nu_i - \nu_e) = 13.65 \frac{gm}{m^3}$$

Ardex 8+9 without PE (Zone 1.2)

$$\nu_1 := \nu_e + \frac{Z_{p;e} + Z_{p;gb}}{Z_{p;tot;ardex}} \cdot (\nu_i - \nu_e) = 2.16 \frac{gm}{m^3}$$

$$\nu_2 := \nu_e + \frac{Z_{p;e} + Z_{p;gb} + Z_{p;sw;200}}{Z_{p;tot;ardex}} \cdot (\nu_i - \nu_e) = 4.868 \frac{gm}{m^3}$$

$$\nu_3 := \nu_e + \frac{Z_{p;e} + Z_{p;gb} + Z_{p;sw;200} + Z_{p;sw;50}}{Z_{p;tot;ardex}} \cdot (\nu_i - \nu_e) = 5.545 \frac{gm}{m^3}$$

Kiilto with PE (Zone 2.1)

$$\nu_1 := \nu_e + \frac{Z_{p;e} + Z_{p;gb}}{Z_{p;tot;kiilto;pe}} \cdot (\nu_i - \nu_e) = 1.246 \frac{gm}{m^3}$$

$$\nu_2 := \nu_e + \frac{Z_{p;e} + Z_{p;gb} + Z_{p;sw;200}}{Z_{p;tot;kiilto;pe}} \cdot (\nu_i - \nu_e) = 1.304 \frac{gm}{m^3}$$

$$\nu_3 := \nu_e + \frac{Z_{p;e} + Z_{p;gb} + Z_{p;sw;200} + Z_{p;pe}}{Z_{p;tot;kiilto;pe}} \cdot (\nu_i - \nu_e) = 13.549 \frac{gm}{m^3}$$

$$\nu_4 := \nu_e + \frac{Z_{p;e} + Z_{p;gb} + Z_{p;sw;200} + Z_{p;pe} + Z_{p;sw;50}}{Z_{p;tot;kiilto;pe}} \cdot (\nu_i - \nu_e) = 13.564 \frac{gm}{m^3}$$

Kiilto without PE (Zone 2.2)

$$\nu_1 := \nu_e + \frac{Z_{p,e} + Z_{p,gb}}{Z_{p,tot;kiilto}} \cdot (\nu_i - \nu_e) = 1.933 \frac{gm}{m^3}$$

$$\nu_2 := \nu_e + \frac{Z_{p,e} + Z_{p,gb} + Z_{p,sw;200}}{Z_{p,tot;kiilto}} \cdot (\nu_i - \nu_e) = 3.982 \frac{gm}{m^3}$$

$$\nu_3 := \nu_e + \frac{Z_{p,e} + Z_{p,gb} + Z_{p,sw;200} + Z_{p,sw;50}}{Z_{p,tot;kiilto}} \cdot (\nu_i - \nu_e) = 4.495 \frac{gm}{m^3}$$

## Stage 2

**water vapour flow through a 10mm holes**

(penetrating the membrane, gypsumboard and vapour barrier)

$$A_{hole} := \frac{\pi \cdot (10 \text{ mm})^2}{4} = (7.854 \cdot 10^{-5}) \text{ m}^2 \quad \text{area of 10mm hole}$$

$$Z_{p;hole,tot} := Z_{p,i} + Z_{p,sw;50} + Z_{p,sw;200} + Z_{p,gb} + Z_{p,e} = (3.087 \cdot 10^9) \frac{m}{s}$$

$$G_{hole} := \frac{p_{vi} - p_{ve}}{Z_{p;hole,tot}} \cdot A_{hole} = (4.384 \cdot 10^{-11}) \frac{kg}{s}$$

**Moisture gradients** (assuming steady-state conditions, in area of punctuated vapour barrier)

$$\nu_1 := \nu_e + \frac{Z_{p,e} + Z_{p,gb}}{Z_{p;hole,tot}} \cdot (\nu_i - \nu_e) = 3.909 \frac{gm}{m^3}$$

$$\nu_2 := \nu_e + \frac{Z_{p,e} + Z_{p,gb} + Z_{p,sw;200}}{Z_{p;hole,tot}} \cdot (\nu_i - \nu_e) = 11.686 \frac{gm}{m^3}$$

$$\nu_3 := \nu_e + \frac{Z_{p,e} + Z_{p,gb} + Z_{p,sw;200} + Z_{p,sw;50}}{Z_{p;hole,tot}} \cdot (\nu_i - \nu_e) = 13.631 \frac{gm}{m^3}$$



## Sensor Data Report - 14.04.2017 to 30.04.2017

Modul	Date	T1	RH1	AH 1	T2	RH2	AH 2	T3	RH3	AH 3	T4	RH4	AH 4
Moduuli_222	14.4.17 0:17	18,76	17,74	2,74	9,18	27,82	2,31				-13,50	80,60	1,25
Moduuli_222	14.4.17 1:17	18,60	17,66	2,70	9,00	27,92	2,29	-13,74	85,08	1,29	-13,15	80,12	1,27
Moduuli_222	14.4.17 2:17	18,47	17,52	2,66	8,82	27,70	2,24	-14,23	85,64	1,25	-13,54	80,68	1,24
Moduuli_222	14.4.17 3:17	18,34	17,38	2,61	8,66	27,65	2,21	-13,75	85,79	1,30	-12,70	80,85	1,33
Moduuli_222	14.4.17 4:17	18,22	17,31	2,58	8,54	27,46	2,18	-14,62					
Moduuli_222	14.4.17 5:17	18,16	17,98	2,67	8,96	30,71	2,51	-2,60	81,36	2,93	-1,16	77,03	3,09
Moduuli_222	14.4.17 6:17	18,22	18,00	2,69	9,56	27,53	2,34				-13,08	79,30	1,27
Moduuli_222	14.4.17 7:17	18,17	17,72	2,64	9,08	27,31	2,25				-12,62	80,63	1,34
Moduuli_222	14.4.17 8:17	18,12	17,64	2,62	8,76	27,62	2,23						
Moduuli_222	14.4.17 9:17	18,13	17,64	2,62	8,60	27,92	2,23	-13,45	85,12	1,32	-12,62	80,53	1,34
Moduuli_222	14.4.17 10:17	18,12	17,64	2,62	8,50	27,95	2,21	-14,39	84,99	1,22	-13,88	79,94	1,20
Moduuli_222	14.4.17 11:17	18,14	17,51	2,60	8,44	27,87	2,20				-13,12	80,37	1,28
Moduuli_222	14.4.17 12:17	18,27	17,55	2,63	8,44	28,05	2,21	-14,48			-13,88	79,02	1,18
Moduuli_222	14.4.17 12:18	18,26	17,55	2,63	8,44	28,02	2,21	-14,52	84,64	1,20	-13,95	79,03	1,18
Moduuli_222	14.4.17 13:17	18,44	18,16	2,75	8,92	31,17	2,54	-2,92	81,56	2,87	-1,52	76,81	3,00
Moduuli_222	14.4.17 14:17	18,70	18,28	2,81	9,66	28,19	2,41	-13,12	82,04	1,31	-13,04	78,92	1,27
Moduuli_222	14.4.17 15:17	18,94	18,03	2,81	9,38	28,10	2,36				-12,60	80,19	1,33
Moduuli_222	14.4.17 16:17	18,95	17,93	2,80	9,19	28,23	2,34				-13,58	79,81	1,23
Moduuli_222	14.4.17 17:17	19,02	17,82	2,80	9,12	28,39	2,34				-12,85	79,74	1,30
Moduuli_222	14.4.17 18:17	18,97	17,71	2,77	9,05	28,12	2,31	-14,28			-13,64	79,77	1,22
Moduuli_222	14.4.17 19:17	18,84	17,54	2,72	8,96	27,90	2,28	-13,76	86,08	1,30	-12,66	79,95	1,32
Moduuli_222	14.4.17 20:17	18,74	17,37	2,68	8,87	27,62	2,24				-13,94	79,13	1,18
Moduuli_222	14.4.17 21:17	18,64	17,93	2,75	9,26	30,68	2,56	-2,32	82,00	3,02	-0,77	76,59	3,16
Moduuli_222	14.4.17 22:17	18,66	17,94	2,75	9,86	27,43	2,38				-12,96	78,32	1,26
Moduuli_222	14.4.17 23:17	18,54	17,64	2,69	9,37	27,15	2,28	-13,14	84,19	1,34	-12,56	79,56	1,33
Moduuli_222	15.4.17 0:17	18,40	17,53	2,65	9,01	27,32	2,24	-13,98	84,53	1,26	-13,56	79,03	1,22
Moduuli_222	15.4.17 1:17	18,31	17,44	2,62	8,80	27,54	2,23	-13,63	84,64	1,29	-13,00	78,63	1,27
Moduuli_222	15.4.17 2:17	18,22	17,34	2,59	8,64	27,43	2,19						
Moduuli_222	15.4.17 3:17	18,14	17,25	2,56	8,51	27,45	2,18	-13,76	85,31	1,29	-12,72	79,07	1,30
Moduuli_222	15.4.17 4:17	18,08	17,23	2,55	8,40	27,35	2,15	-14,64			-14,02	78,16	1,16
Moduuli_222	15.4.17 5:17	18,02	17,80	2,62	8,80	30,42	2,46	-2,04	82,09	3,08	-0,32	76,84	3,28
Moduuli_222	15.4.17 6:17	18,11	17,96	2,66	9,46	27,43	2,32	-12,92	81,32	1,32	-12,82	77,74	1,27
Moduuli_222	15.4.17 7:17	18,06	17,69	2,61	8,98	27,16	2,22				-12,86	78,95	1,29
Moduuli_222	15.4.17 8:17	18,00	17,57	2,59	8,68	27,50	2,20	-14,14	83,90	1,23	-13,82		
Moduuli_222	15.4.17 9:17	18,00	17,54	2,58	8,52	27,64	2,19	-13,58	84,77	1,30	-12,84	78,78	1,28
Moduuli_222	15.4.17 10:17	18,02	17,51	2,58	8,41	27,79	2,19						
Moduuli_222	15.4.17 11:17	18,10	17,50	2,59	8,36	27,78	2,18				-13,36	78,72	1,23
Moduuli_222	15.4.17 12:17	18,20	17,47	2,60	8,38	27,91	2,19				-13,14	78,09	1,24
Moduuli_222	15.4.17 13:17	18,40	17,99	2,72	8,82	30,89	2,50	-2,35	82,34	3,02	-0,65	76,83	3,20
Moduuli_222	15.4.17 14:17	18,63	18,12	2,78	9,62	28,02	2,39	-12,78	81,90	1,34	-12,60	78,06	1,30
Moduuli_222	15.4.17 15:17	18,76	17,90	2,76	9,30	27,82	2,33	-13,36	84,10	1,31	-12,86	79,07	1,29
Moduuli_222	15.4.17 16:17	18,92	17,82	2,78	9,13	28,14	2,33	-14,10			-13,72	78,55	1,19
Moduuli_222	15.4.17 17:17	18,93	17,70	2,76	9,05	28,18	2,32	-13,48	85,40	1,32	-12,64	79,24	1,31
Moduuli_222	15.4.17 18:17	19,03	17,66	2,77	9,03	28,14	2,31				-13,80	78,88	1,19
Moduuli_222	15.4.17 19:17	19,04	17,53	2,75	9,00	27,95	2,29				-12,88	79,44	1,29
Moduuli_222	15.4.17 20:17	18,94	17,37	2,71	8,96	27,71	2,26	-14,58			-13,94	78,53	1,17
Moduuli_222	15.4.17 21:17	18,85	17,87	2,77	9,32	30,52	2,55	-1,72	82,98	3,19	0,10	77,58	3,41
Moduuli_222	15.4.17 22:17	18,84	17,93	2,78	10,02	27,42	2,41	-12,83	81,79	1,33	-12,74	78,19	1,29
Moduuli_222	15.4.17 23:17	18,73	17,57	2,71	9,50	27,04	2,29	-13,20	84,15	1,33	-12,64	79,47	1,32
Moduuli_222	16.4.17 0:17	18,58	17,39	2,65	9,12	27,20	2,25	-14,00			-13,60	79,04	1,21
Moduuli_222	16.4.17 1:17	18,44	17,35	2,62	8,90	27,35	2,23				-12,80	79,09	1,29
Moduuli_222	16.4.17 2:17	18,32	17,24	2,59	8,74	27,24	2,19				-13,66	79,14	1,21
Moduuli_222	16.4.17 3:17	18,22	17,15	2,56	8,58	27,16	2,16				-12,74	79,48	1,31
Moduuli_222	16.4.17 4:17	18,13	17,05	2,53	8,48	27,12	2,15						
Moduuli_222	16.4.17 5:17	18,10	17,63	2,61	8,81	30,04	2,43	-1,60	83,22	3,23	0,35	78,42	3,51
Moduuli_222	16.4.17 6:17	18,16	17,81	2,65	9,54	27,27	2,32	-12,82	81,35	1,33	-12,74	78,12	1,28
Moduuli_222	16.4.17 7:17	18,12	17,57	2,61	9,05	26,99	2,22	-13,34	83,72	1,31	-12,82	79,36	1,30
Moduuli_222	16.4.17 8:17	18,06	17,49	2,58	8,74	27,33	2,20	-14,16	83,94	1,23	-13,84	78,62	1,18

Moduuli_222	16.4.17 9:17	18,03	17,41	2,57	8,56	27,53	2,19	-13,58	84,80	1,30	-12,82	79,31	1,30
Moduuli_222	16.4.17 10:17	18,04	17,42	2,57	8,47	27,66	2,19	-14,38					
Moduuli_222	16.4.17 11:17	18,09	17,37	2,57	8,42	27,61	2,17	-14,15	85,19	1,25	-13,31	79,38	1,25
Moduuli_222	16.4.17 12:17	18,18	17,36	2,59	8,40	27,73	2,18				-13,34	78,55	1,23
Moduuli_222	16.4.17 13:17	18,28	17,88	2,68	8,78	30,53	2,46	-1,88	83,62	3,18	0,08	78,89	3,46
Moduuli_222	16.4.17 14:17	18,46	18,07	2,74	9,59	27,91	2,38	-12,60	82,08	1,36	-13,04	78,55	1,26
Moduuli_222	16.4.17 15:17	18,62	17,86	2,73	9,24	27,68	2,30	-13,44	84,12	1,31	-12,96	79,61	1,29
Moduuli_222	16.4.17 16:17	18,72	17,79	2,74	9,04	28,02	2,30	-14,06	84,50	1,25	-13,70	79,11	1,20
Moduuli_222	16.4.17 17:17	18,76	17,68	2,73	8,96	28,15	2,30	-13,44	85,41	1,33	-12,60	79,82	1,33
Moduuli_222	16.4.17 18:17	18,75	17,61	2,72	8,90	28,01	2,28	-14,32			-13,76	79,48	1,20
Moduuli_222	16.4.17 19:17	18,70	17,49	2,69	8,84	27,83	2,26				-12,83	80,02	1,31
Moduuli_222	16.4.17 20:17	18,63	17,34	2,66	8,77	27,66	2,23				-13,98	79,17	1,18
Moduuli_222	16.4.17 21:17	18,56	17,78	2,71	9,09	30,41	2,51	-1,49	84,24	3,30	0,53	79,62	3,61
Moduuli_222	16.4.17 22:17	18,60	17,98	2,75	9,84	27,55	2,39	-12,48	82,39	1,38	-12,25	79,27	1,36
Moduuli_222	16.4.17 23:17	18,48	17,62	2,67	9,34	27,14	2,28				-12,78	79,94	1,31
Moduuli_222	17.4.17 0:17	18,34	17,51	2,63	8,98	27,34	2,24	-14,08	84,49	1,25	-13,72	79,45	1,21
Moduuli_222	17.4.17 1:17	18,22	17,41	2,60	8,72	27,48	2,21	-13,42	85,21	1,33	-12,58	79,95	1,33
Moduuli_222	17.4.17 2:17	18,10	17,34	2,57	8,58	27,44	2,18	-14,30	85,10	1,23	-13,76	79,58	1,20
Moduuli_222	17.4.17 3:17	18,04	17,25	2,55	8,45	27,37	2,16	-13,86			-12,86	80,06	1,30
Moduuli_222	17.4.17 4:17	17,98	17,20	2,53	8,35	27,40	2,15				-13,98	79,12	1,18
Moduuli_222	17.4.17 5:17	17,94	17,71	2,60	8,64	30,18	2,41	-1,44	84,40	3,31	0,66	80,29	3,67
Moduuli_222	17.4.17 6:17	18,01	17,96	2,65	9,42	27,55	2,32	-12,38	82,30	1,39	-12,08	79,54	1,38
Moduuli_222	17.4.17 7:17	17,99	17,66	2,60	8,96	27,21	2,22				-13,02	79,91	1,28
Moduuli_222	17.4.17 8:17	17,96	17,62	2,59	8,65	27,59	2,21						
Moduuli_222	17.4.17 9:17	17,98	17,59	2,59	8,47	27,75	2,19	-13,66	84,99	1,30	-12,92	79,89	1,29
Moduuli_222	17.4.17 10:17	18,02	17,61	2,60	8,40	27,92	2,20	-14,41	84,70	1,22	-13,95	79,13	1,18
Moduuli_222	17.4.17 11:17	18,04	17,51	2,58	8,37	27,84	2,19				-13,30	79,82	1,25
Moduuli_222	17.4.17 12:17	18,17	17,46	2,60	8,39	27,98	2,20	-14,20	84,74	1,24	-13,44	78,77	1,22
Moduuli_222	17.4.17 13:17	18,27	17,95	2,69	8,70	30,63	2,46	-1,69	84,74	3,27	0,42	80,34	3,61
Moduuli_222	17.4.17 14:17	18,52	18,22	2,77	9,60	28,10	2,40	-12,38	82,56	1,40	-12,07	79,30	1,38
Moduuli_222	17.4.17 15:17	18,66	17,94	2,75	9,26	27,81	2,32				-12,96	79,69	1,29
Moduuli_222	17.4.17 16:17	18,71	17,89	2,75	9,07	28,16	2,32						
Moduuli_222	17.4.17 17:17	18,79	17,78	2,75	8,99	28,26	2,31	-13,60	85,17	1,31	-12,95	79,07	1,28
Moduuli_222	17.4.17 18:17	18,75	17,64	2,72	8,90	28,01	2,28				-13,56	79,32	1,22
Moduuli_222	17.4.17 19:17	18,69	17,49	2,69	8,83	27,92	2,26	-13,74	85,89	1,30	-12,70	79,42	1,31
Moduuli_222	17.4.17 20:17	18,60	17,33	2,65	8,74	27,65	2,23	-14,56	85,44	1,21	-13,86	78,78	1,18
Moduuli_222	17.4.17 21:17	18,52	17,76	2,70	9,03	30,30	2,49	-1,24	85,05	3,39	0,93	80,12	3,74
Moduuli_222	17.4.17 22:17	18,55	18,00	2,74	9,84	27,55	2,39	-12,31	82,44	1,40	-12,02	78,79	1,37
Moduuli_222	17.4.17 23:17	18,44	17,61	2,66	9,32	27,07	2,27	-13,37	84,00	1,31	-12,90	79,06	1,28
Moduuli_222	18.4.17 0:17	18,30	17,50	2,62	8,94	27,33	2,23						
Moduuli_222	18.4.17 1:17	18,18	17,40	2,59	8,70	27,45	2,20	-13,46	84,95	1,32	-12,66	78,84	1,30
Moduuli_222	18.4.17 2:17	18,08	17,36	2,57	8,53	27,39	2,17	-14,40			-13,90	78,20	1,17
Moduuli_222	18.4.17 3:17	18,00	17,24	2,54	8,39	27,28	2,14				-13,08	78,66	1,26
Moduuli_222	18.4.17 4:17	17,92	17,18	2,52	8,31	27,32	2,14	-14,52			-13,91	77,25	1,15
Moduuli_222	18.4.17 5:17	17,87	17,56	2,56	8,54	29,84	2,37	-1,47	84,98	3,33	0,76	79,97	3,69
Moduuli_222	18.4.17 6:17	17,96	17,91	2,63	9,37	27,50	2,31	-12,26	82,09	1,40	-11,94	78,32	1,37
Moduuli_222	18.4.17 7:17	17,94	17,65	2,59	8,90	27,13	2,21	-13,48	83,48	1,29	-13,06	78,46	1,26
Moduuli_222	18.4.17 8:17	17,89	17,57	2,57	8,58	27,47	2,19				-14,48	77,17	1,10
Moduuli_222	18.4.17 9:17	17,88	17,50	2,56	8,36	27,62	2,17						
Moduuli_222	18.4.17 10:17	17,96	17,52	2,57	8,32	27,92	2,18				-12,88	77,95	1,27
Moduuli_222	18.4.17 11:17	18,19	17,53	2,61	8,34	27,96	2,19				-13,82	77,93	1,17
Moduuli_222	18.4.17 12:17	18,46	17,55	2,66	8,42	28,11	2,21	-13,97	85,10	1,27	-12,92	78,16	1,27
Moduuli_222	18.4.17 13:17	18,79	17,98	2,78	8,82	30,67	2,48	-2,08	85,37	3,20	0,12	79,89	3,52
Moduuli_222	18.4.17 14:17	19,22	18,31	2,91	9,87	28,57	2,48	-12,35	82,77	1,40	-11,96	78,16	1,37
Moduuli_222	18.4.17 15:17	19,01	17,92	2,81	9,52	27,73	2,35	-13,54	84,13	1,30	-13,10	78,30	1,25
Moduuli_222	18.4.17 16:17	19,32	17,88	2,86	9,36	28,22	2,37	-14,14			-13,76	77,52	1,17
Moduuli_222	18.4.17 17:17	19,52	17,75	2,87	9,34	28,27	2,37				-12,84	78,43	1,28
Moduuli_222	18.4.17 18:17	19,48	17,54	2,83	9,32	28,05	2,35						
Moduuli_222	18.4.17 19:17	19,42	17,36	2,79	9,25	27,71	2,31	-13,94			-12,90	78,39	1,27
Moduuli_222	18.4.17 20:17	19,31	17,16	2,74	9,19	27,41	2,27						
Moduuli_222	18.4.17 21:17	19,18	17,45	2,77	9,42	29,74	2,51	-1,24	85,74	3,42	1,06	79,91	3,76
Moduuli_222	18.4.17 22:17	19,18	17,71	2,81	10,26	27,18	2,42	-12,18	82,43	1,42	-11,86	77,95	1,38
Moduuli_222	18.4.17 23:17	19,01	17,33	2,72	9,72	26,63	2,29	-13,38	83,80	1,31	-12,90	78,07	1,27

Moduuli_222	19.4.17 0:17	18,82	17,14	2,66	9,31	26,79	2,24	-14,06	84,04	1,24	-13,68	77,32	1,18
Moduuli_222	19.4.17 1:17	18,65	17,02	2,61	9,04	26,92	2,21	-13,41	84,78	1,32	-12,56	77,78	1,30
Moduuli_222	19.4.17 2:17	18,50	16,94	2,57	8,82	26,79	2,17						
Moduuli_222	19.4.17 3:17	18,36	16,86	2,54	8,66	26,68	2,14	-13,86			-12,82	77,59	1,27
Moduuli_222	19.4.17 4:17	18,23	16,79	2,51	8,52	26,63	2,11				-14,02	76,57	1,13
Moduuli_222	19.4.17 5:17	18,14	17,15	2,55	8,70	29,14	2,34	-1,49	85,07	3,33	0,80	79,43	3,67
Moduuli_222	19.4.17 6:17	18,19	17,59	2,62	9,58	26,97	2,30	-12,17	81,65	1,41	-11,86	77,35	1,36
Moduuli_222	19.4.17 7:17	18,16	17,26	2,57	9,09	26,53	2,19	-13,50	82,99	1,28	-13,12	77,38	1,23
Moduuli_222	19.4.17 8:17	18,13	17,25	2,56	8,74	26,95	2,17	-14,14	83,03	1,22	-13,86	76,32	1,15
Moduuli_222	19.4.17 9:17	18,14	17,19	2,55	8,57	27,15	2,16	-13,68	84,09	1,28	-12,96	77,18	1,25
Moduuli_222	19.4.17 10:17	18,21	17,21	2,57	8,50	27,32	2,16	-14,42	83,81	1,20	-13,98	76,28	1,13
Moduuli_222	19.4.17 11:17	18,37	17,19	2,59	8,48	27,44	2,17				-13,26	77,11	1,22
Moduuli_222	19.4.17 12:17	18,49	17,16	2,61	8,50	27,51	2,18				-13,66	75,78	1,16
Moduuli_222	19.4.17 13:17	18,73	17,60	2,71	8,84	30,09	2,44	-1,72	85,15	3,28	0,60	79,31	3,61
Moduuli_222	19.4.17 14:17	19,04	17,99	2,83	9,93	27,92	2,44				-11,84	77,25	1,37
Moduuli_222	19.4.17 15:17	18,93	17,57	2,74	9,58	27,15	2,31	-13,42	83,59	1,30	-12,98	77,44	1,25
Moduuli_222	19.4.17 16:17	19,02	17,59	2,76	9,27	27,56	2,30				-13,66	76,70	1,17
Moduuli_222	19.4.17 17:17	19,16	17,51	2,77	9,20	27,85	2,31	-13,36	84,87	1,33	-12,56	77,30	1,29
Moduuli_222	19.4.17 18:17	19,24	17,40	2,77	9,17	27,72	2,30				-13,56	76,99	1,18
Moduuli_222	19.4.17 19:17	19,25	17,27	2,75	9,14	27,61	2,28	-13,70	85,28	1,30	-12,70	77,13	1,27
Moduuli_222	19.4.17 20:17	19,20	17,13	2,72	9,08	27,28	2,25						
Moduuli_222	19.4.17 21:17	19,10	17,42	2,75	9,34	29,62	2,48	-1,30	85,45	3,39	1,02	79,22	3,72
Moduuli_222	19.4.17 22:17	19,12	17,76	2,80	10,26	27,18	2,42	-12,08	81,98	1,42	-11,78	77,12	1,37
Moduuli_222	19.4.17 23:17	19,00	17,33	2,72	9,72	26,57	2,28	-13,34	83,40	1,31			
Moduuli_222	20.4.17 0:17	18,83	17,14	2,66	9,30	26,75	2,24	-14,06	83,68	1,24	-13,71	76,44	1,16
Moduuli_222	20.4.17 1:17	18,67	17,06	2,62	9,04	26,92	2,21	-13,36	84,43	1,32	-12,55	76,85	1,28
Moduuli_222	20.4.17 2:17	18,52	16,91	2,57	8,84	26,77	2,17	-14,31			-13,72	76,41	1,16
Moduuli_222	20.4.17 3:17	18,41	16,84	2,54	8,68	26,71	2,14	-13,74	84,60	1,28	-12,70	76,68	1,26
Moduuli_222	20.4.17 4:17	18,29	16,71	2,51	8,56	26,58	2,11	-14,62	83,99	1,18	-14,01	75,79	1,12
Moduuli_222	20.4.17 5:17	18,21	17,08	2,55	8,70	28,95	2,32	-1,64	84,88	3,28	0,68	78,75	3,61
Moduuli_222	20.4.17 6:17	18,26	17,55	2,63	9,64	26,89	2,30	-12,14	81,27	1,40	-11,88	76,59	1,35
Moduuli_222	20.4.17 7:17	18,24	17,28	2,58	9,16	26,46	2,19						
Moduuli_222	20.4.17 8:17	18,20	17,20	2,56	8,81	26,85	2,17						
Moduuli_222	20.4.17 9:17	18,28	17,16	2,57	8,66	27,12	2,17	-13,51	83,86	1,30	-12,79	76,35	1,25
Moduuli_222	20.4.17 10:17	18,35	17,19	2,59	8,59	27,28	2,17	-14,36	83,68	1,21	-13,90	75,65	1,13
Moduuli_222	20.4.17 11:17	18,46	17,16	2,60	8,56	27,28	2,17	-14,00	84,30	1,25	-13,10	76,40	1,22
Moduuli_222	20.4.17 12:17	18,62	17,14	2,62	8,60	27,41	2,19	-14,50	83,62	1,19	-13,94	75,18	1,12
Moduuli_222	20.4.17 13:17	18,75	17,44	2,69	8,88	29,69	2,41	-1,94	84,93	3,22	0,35	78,70	3,52
Moduuli_222	20.4.17 14:17	18,83	17,86	2,77	9,90	27,51	2,39	-12,14	81,54	1,41	-11,88	76,74	1,35
Moduuli_222	20.4.17 15:17	19,01	17,59	2,76	9,56	27,15	2,31	-13,42	83,11	1,29	-13,04	76,88	1,23
Moduuli_222	20.4.17 16:17	18,99	17,45	2,73	9,29	27,38	2,29						
Moduuli_222	20.4.17 17:17	18,94	17,31	2,70	9,12	27,36	2,26				-12,71	76,98	1,27
Moduuli_222	20.4.17 18:17	18,89	17,19	2,68	9,02	27,29	2,24	-14,32	84,42	1,22	-13,80	76,44	1,15
Moduuli_222	20.4.17 19:17	18,77	17,06	2,64	8,90	27,07	2,20	-13,86	84,85	1,27	-12,90	76,97	1,25
Moduuli_222	20.4.17 20:17	18,70	16,90	2,60	8,80	26,91	2,18	-14,58	84,17	1,19	-13,98	75,93	1,13
Moduuli_222	20.4.17 21:17	18,62	17,17	2,63	8,95	29,09	2,38	-1,89	85,24	3,24	0,42	79,00	3,55
Moduuli_222	20.4.17 22:17	18,64	17,60	2,70	9,92	27,01	2,35	-12,08	81,49	1,41	-11,82	76,88	1,36
Moduuli_222	20.4.17 23:17	18,56	17,25	2,63	9,43	26,45	2,23	-13,38	82,98	1,30	-13,02	77,03	1,24
Moduuli_222	21.4.17 0:17	18,42	17,14	2,59	9,06	26,71	2,20	-14,02			-13,71		
Moduuli_222	21.4.17 1:17	18,30	17,04	2,56	8,82	26,79	2,17				-12,60	76,96	1,28
Moduuli_222	21.4.17 2:17	18,24	16,99	2,54	8,67	26,87	2,15				-13,74	76,48	1,16
Moduuli_222	21.4.17 3:17	18,20	16,94	2,53	8,56	26,83	2,13	-13,76	84,45	1,28	-12,76	76,96	1,26
Moduuli_222	21.4.17 4:17	18,14	16,86	2,50	8,46	26,80	2,12	-14,50	83,88	1,19	-13,90	76,10	1,14
Moduuli_222	21.4.17 5:17	18,11	17,18	2,55	8,64	28,99	2,32	-2,00	84,94	3,20	0,32	79,05	3,53
Moduuli_222	21.4.17 6:17	18,26	17,68	2,65	9,66	27,09	2,32	-12,17	81,26	1,40	-11,95	76,92	1,35
Moduuli_222	21.4.17 7:17	18,26	17,35	2,60	9,20	26,63	2,21	-13,52	82,74	1,28	-13,20	77,00	1,22
Moduuli_222	21.4.17 8:17	18,32	17,31	2,60	8,88	27,09	2,20				-13,82	76,05	1,15
Moduuli_222	21.4.17 9:17	18,48	17,29	2,62	8,80	27,35	2,21				-12,90	77,14	1,25
Moduuli_222	21.4.17 10:17	18,65	17,28	2,65	8,80	27,54	2,23				-13,84		
Moduuli_222	21.4.17 11:17	18,74	17,18	2,65	8,82	27,42	2,22						
Moduuli_222	21.4.17 12:17	18,88	17,16	2,67	8,88	27,50	2,23				-13,92	76,70	1,15
Moduuli_222	21.4.17 13:17	18,17	17,20	2,56	8,82	28,74	2,33	-2,22	85,35	3,17	0,08	79,68	3,50
Moduuli_222	21.4.17 14:17	18,69	17,88	2,75	9,86	27,40	2,38	-12,17	81,61	1,40	-11,98	77,66	1,36

Moduuli_222	21.4.17 15:17	19,10	17,62	2,78	9,62	27,26	2,33	-13,46	83,36	1,29	-13,14	77,99	1,24
Moduuli_222	21.4.17 16:17	19,46	17,60	2,84	9,51	27,82	2,36	-14,00	83,87	1,24	-13,75	77,45	1,17
Moduuli_222	21.4.17 17:17	19,78	17,57	2,89	9,56	28,03	2,38	-13,36	85,18	1,33	-12,62	78,60	1,30
Moduuli_222	21.4.17 18:17	19,89	17,41	2,88	9,62	27,83	2,38						
Moduuli_222	21.4.17 19:17	20,05	17,26	2,89	9,67	27,78	2,38				-12,64	79,04	1,31
Moduuli_222	21.4.17 20:17	20,00	17,05	2,84	9,68	27,31	2,34				-13,56	78,90	1,21
Moduuli_222	21.4.17 21:17	19,93	17,29	2,87	9,88	29,26	2,54	-1,94	86,34	3,27	0,40	80,96	3,64
Moduuli_222	21.4.17 22:17	19,88	17,60	2,91	10,88	26,93	2,50	-12,05	82,57	1,44	-11,85	78,90	1,39
Moduuli_222	21.4.17 23:17	19,62	17,13	2,79	10,32	26,19	2,34	-13,34	84,17	1,32	-12,98	79,21	1,28
Moduuli_222	22.4.17 0:17	19,34	16,91	2,71	9,82	26,28	2,28	-14,00	84,45	1,25	-13,70	78,61	1,20
Moduuli_222	22.4.17 1:17	19,10	16,77	2,64	9,50	26,40	2,24	-13,32	85,21	1,34	-12,54	79,17	1,32
Moduuli_222	22.4.17 2:17	18,90	16,64	2,59	9,24	26,23	2,18				-13,56	78,98	1,21
Moduuli_222	22.4.17 3:17	18,70	16,54	2,54	9,06	26,23	2,16						
Moduuli_222	22.4.17 4:17	18,54	16,46	2,51	8,88	26,02	2,11						
Moduuli_222	22.4.17 5:17	18,41	16,75	2,53	8,95	28,21	2,30	-2,20	85,73	3,18	0,12	80,97	3,56
Moduuli_222	22.4.17 6:17	18,50	17,30	2,63	9,94	26,54	2,32	-12,08	81,68	1,42	-11,94	78,57	1,38
Moduuli_222	22.4.17 7:17	18,54	17,05	2,60	9,48	26,15	2,21	-13,48	83,24	1,29	-13,22	78,76	1,25
Moduuli_222	22.4.17 8:17	18,52	16,98	2,58	9,12	26,57	2,19	-14,02	83,43	1,24	-13,78	77,89	1,18
Moduuli_222	22.4.17 9:17	18,51	16,97	2,58	8,95	26,77	2,19	-13,46	84,54	1,31	-12,78	78,80	1,29
Moduuli_222	22.4.17 10:17	18,56	16,92	2,58	8,88	26,94	2,19	-14,28	84,45	1,22	-13,82	78,32	1,18
Moduuli_222	22.4.17 11:17	18,63	16,95	2,60	8,82	26,92	2,18				-12,94	78,97	1,28
Moduuli_222	22.4.17 12:17	18,68	16,90	2,60	8,82	26,92	2,18						
Moduuli_222	22.4.17 13:17	18,77	17,19	2,66	8,99	28,98	2,37	-2,50	85,78	3,12	-0,22	80,99	3,48
Moduuli_222	22.4.17 14:17	19,01	17,72	2,78	10,14	27,33	2,42				-12,08	78,65	1,36
Moduuli_222	22.4.17 15:17	19,15	17,44	2,76	9,78	26,90	2,32				-13,36	78,92	1,23
Moduuli_222	22.4.17 16:17	19,29	17,35	2,77	9,54	27,33	2,32	-13,94	83,82	1,25	-13,69	78,12	1,19
Moduuli_222	22.4.17 17:17	19,38	17,25	2,77	9,46	27,37	2,31	-13,58	85,18	1,31	-12,90	79,38	1,29
Moduuli_222	22.4.17 18:17	19,38	17,18	2,76	9,40	27,35	2,30	-14,24	85,11	1,24	-13,80	78,95	1,19
Moduuli_222	22.4.17 19:17	19,32	17,03	2,72	9,34	27,08	2,27				-12,87	79,76	1,30
Moduuli_222	22.4.17 20:17	19,27	16,88	2,69	9,26	26,93	2,25	-14,50			-13,93	79,08	1,18
Moduuli_222	22.4.17 21:17	19,14	17,07	2,70	9,33	28,71	2,40	-2,45	86,33	3,15	-0,14	81,69	3,53
Moduuli_222	22.4.17 22:17	19,14	17,56	2,78	10,34	26,92	2,41	-12,12	82,21	1,42	-11,96	79,28	1,39
Moduuli_222	22.4.17 23:17	19,02	17,13	2,69	9,85	26,29	2,28				-13,24	79,62	1,26
Moduuli_222	23.4.17 0:17	18,88	17,03	2,65	9,42	26,57	2,24	-14,01	83,89	1,24			
Moduuli_222	23.4.17 1:17	18,76	16,92	2,61	9,16	26,65	2,21	-13,63	85,02	1,30	-12,97	79,86	1,29
Moduuli_222	23.4.17 2:17	18,67	16,89	2,59	9,01	26,72	2,19				-13,96	79,02	1,18
Moduuli_222	23.4.17 3:17	18,63	16,82	2,58	8,88	26,62	2,16	-14,12	85,34	1,25	-13,32	79,97	1,25
Moduuli_222	23.4.17 4:17	18,55	16,73	2,55	8,79	26,69	2,16	-14,06	84,84	1,25	-13,26	79,24	1,25
Moduuli_222	23.4.17 5:17	18,49	16,90	2,57	8,81	28,36	2,29	-3,12	86,21	2,99	-0,82	82,03	3,37
Moduuli_222	23.4.17 6:17	18,58	17,52	2,67	9,86	26,99	2,34	-12,14	82,01	1,41	-11,98	79,40	1,39
Moduuli_222	23.4.17 7:17	18,55	17,18	2,62	9,45	26,45	2,23				-13,30	79,73	1,25
Moduuli_222	23.4.17 8:17	18,55	17,12	2,61	9,08	26,87	2,21				-12,70	80,06	1,32
Moduuli_222	23.4.17 9:17	18,55	17,09	2,60	8,88	26,94	2,19				-14,35	79,69	1,15
Moduuli_222	23.4.17 10:17	18,56	16,99	2,59	8,78	27,09	2,19	-13,84	85,38	1,28	-13,06	80,22	1,29
Moduuli_222	23.4.17 11:17	18,68	17,03	2,62	8,78	27,25	2,20				-13,85	79,26	1,19
Moduuli_222	23.4.17 12:17	18,82	17,01	2,64	8,82	27,20	2,20	-14,30	85,48	1,24	-13,50	80,33	1,24
Moduuli_222	23.4.17 13:17	19,02	17,13	2,69	8,96	28,78	2,35	-3,90	86,77	2,84	-1,62	82,67	3,20
Moduuli_222	23.4.17 14:17	19,32	17,75	2,84	10,10	27,76	2,45				-12,30	79,75	1,36
Moduuli_222	23.4.17 15:17	19,46	17,47	2,82	9,84	27,14	2,35				-13,48		
Moduuli_222	23.4.17 16:17	19,56	17,37	2,82	9,64	27,49	2,35				-13,14	79,97	1,27
Moduuli_222	23.4.17 17:17	19,67	17,21	2,81	9,59	27,47	2,34				-13,26	80,82	1,27
Moduuli_222	23.4.17 18:17	19,67	17,14	2,80	9,55	27,40	2,33				-14,32	79,80	1,15
Moduuli_222	23.4.17 19:17	19,58	16,98	2,76	9,46	27,05	2,29	-14,22	86,31	1,26	-13,38	81,15	1,27
Moduuli_222	23.4.17 20:17	19,42	16,80	2,70	9,37	26,84	2,25				-13,14	80,56	1,28
Moduuli_222	23.4.17 21:17	19,25	16,88	2,69	9,35	28,28	2,37	-3,11	87,18	3,03	-0,78	83,18	3,43
Moduuli_222	23.4.17 22:17	19,22	17,39	2,76	10,38	26,84	2,41	-12,24	82,58	1,41	-12,12	80,25	1,39
Moduuli_222	23.4.17 23:17	19,06	17,02	2,68	9,86	26,11	2,27	-13,64	84,15	1,29	-13,32	80,61	1,26
Moduuli_222	24.4.17 0:17	18,84	16,88	2,62	9,43	26,35	2,22				-13,66	79,79	1,22
Moduuli_222	24.4.17 1:17	18,68	16,77	2,58	9,13	26,41	2,18	-13,66	85,30	1,30			
Moduuli_222	24.4.17 2:17	18,54	16,72	2,55	8,93	26,48	2,16	-14,34			-13,90	79,98	1,20
Moduuli_222	24.4.17 3:17	18,36	16,66	2,51	8,74	26,32	2,12	-14,10			-13,26	80,82	1,27
Moduuli_222	24.4.17 4:17	18,28	16,57	2,48	8,61	26,44	2,11	-14,20			-13,48	79,82	1,24
Moduuli_222	24.4.17 5:17	18,24	16,79	2,51	8,62	28,11	2,24	-3,28	86,53	2,97	-0,98	82,87	3,37

Moduuli_222	24.4.17 6:17	18,35	17,51	2,64	9,71	27,04	2,32	-12,23	82,10	1,41	-12,12	79,95	1,38
Moduuli_222	24.4.17 7:17	18,42	17,21	2,60	9,33	26,48	2,22	-13,64	83,67	1,28	-13,39	80,26	1,25
Moduuli_222	24.4.17 8:17	18,44	17,15	2,60	9,02	26,92	2,21						
Moduuli_222	24.4.17 9:17	18,54	17,12	2,61	8,88	27,09	2,20				-13,22	80,49	1,27
Moduuli_222	24.4.17 10:17	18,60	17,13	2,62	8,83	27,30	2,21				-13,78	79,53	1,20
Moduuli_222	24.4.17 11:17	18,70	17,10	2,63	8,82	27,23	2,20				-13,30	80,61	1,27
Moduuli_222	24.4.17 12:17	18,53	16,92	2,57	8,77	27,03	2,18				-13,51	79,66	1,23
Moduuli_222	24.4.17 13:17	18,67	17,16	2,63	8,84	28,71	2,33	-3,50	86,82	2,93	-1,20	82,82	3,31
Moduuli_222	24.4.17 14:17	19,02	17,85	2,80	10,07	27,75	2,44	-12,32	82,39	1,40	-12,28	79,80	1,36
Moduuli_222	24.4.17 15:17	19,16	17,51	2,77	9,76	27,12	2,34	-13,74	84,05	1,27	-13,52	80,15	1,24
Moduuli_222	24.4.17 16:17	19,37	17,44	2,80	9,54	27,58	2,34				-13,20	79,81	1,26
Moduuli_222	24.4.17 17:17	19,42	17,33	2,79	9,44	27,55	2,33						
Moduuli_222	24.4.17 18:17	19,38	17,21	2,76	9,40	27,44	2,31						
Moduuli_222	24.4.17 19:17	19,34	17,10	2,74	9,32	27,20	2,28				-13,14		
Moduuli_222	24.4.17 20:17	19,25	16,94	2,70	9,23	27,08	2,25				-13,77	79,95	1,21
Moduuli_222	24.4.17 21:17	19,16	17,05	2,70	9,25	28,50	2,37	-3,42	87,18	2,96	-1,12	83,02	3,34
Moduuli_222	24.4.17 22:17	19,17	17,64	2,79	10,32	27,20	2,43	-12,20	82,52	1,42	-12,17	79,98	1,38
Moduuli_222	24.4.17 23:17	19,05	17,24	2,71	9,86	26,42	2,29				-13,42	80,38	1,25
Moduuli_222	25.4.17 0:17	18,89	17,09	2,66	9,44	26,67	2,25	-13,77	84,25	1,27	-13,43	79,64	1,24
Moduuli_222	25.4.17 1:17	18,73	16,98	2,62	9,15	26,70	2,21	-13,76	85,46	1,29	-13,16	80,61	1,28
Moduuli_222	25.4.17 2:17	18,60	16,87	2,58	8,96	26,77	2,19	-14,27			-13,82	79,69	1,20
Moduuli_222	25.4.17 3:17	18,48	16,80	2,55	8,82	26,60	2,15				-13,34	80,65	1,26
Moduuli_222	25.4.17 4:17	18,36	16,73	2,52	8,69	26,62	2,14						
Moduuli_222	25.4.17 5:17	18,26	16,83	2,52	8,62	27,99	2,23	-3,87	86,80	2,85	-1,56	82,83	3,22
Moduuli_222	25.4.17 6:17	18,34	17,58	2,64	9,74	27,20	2,34	-12,24	82,02	1,40	-12,18	79,59	1,37
Moduuli_222	25.4.17 7:17	18,33	17,28	2,60	9,32	26,51	2,22	-13,73	83,59	1,27	-13,54	79,85	1,23
Moduuli_222	25.4.17 8:17	18,32	17,21	2,58	8,98	26,93	2,20	-13,48	84,25	1,30	-13,00	79,77	1,28
Moduuli_222	25.4.17 9:17	18,34	17,18	2,58	8,80	27,10	2,19	-13,88	85,08	1,28	-13,38	80,14	1,25
Moduuli_222	25.4.17 10:17	18,38	17,16	2,59	8,72	27,33	2,20				-13,44	79,26	1,23
Moduuli_222	25.4.17 11:17	18,52	17,17	2,61	8,70	27,35	2,20				-13,59	80,18	1,23
Moduuli_222	25.4.17 12:17	18,64	17,15	2,63	8,72	27,45	2,21				-12,68	80,46	1,33
Moduuli_222	25.4.17 13:17	18,70	17,23	2,65	8,78	28,79	2,32	-4,04	87,04	2,82	-1,74	82,83	3,18
Moduuli_222	25.4.17 14:17	19,00	18,05	2,83	10,04	28,12	2,47	-12,30	82,49	1,41	-12,18	79,68	1,37
Moduuli_222	25.4.17 15:17	19,15	17,70	2,80	9,85	27,30	2,37						
Moduuli_222	25.4.17 16:17	19,21	17,52	2,78	9,45	27,43	2,32	-13,98			-13,52	81,03	1,25
Moduuli_222	25.4.17 17:17	19,18	17,38	2,75	9,24	27,74	2,31	-13,92	86,07	1,29	-13,33	80,65	1,26
Moduuli_222	25.4.17 18:17	19,04	17,21	2,70	9,07	27,47	2,26				-14,94	80,44	1,11
Moduuli_222	25.4.17 19:17	18,95	17,05	2,66	8,93	27,20	2,22				-14,68	81,35	1,14
Moduuli_222	25.4.17 20:17	18,84	16,88	2,62	8,80	27,00	2,18						
Moduuli_222	25.4.17 21:17	18,72	16,84	2,59	8,69	27,85	2,23	-5,54	88,05	2,55	-3,16	84,15	2,91
Moduuli_222	25.4.17 22:17	18,75	17,51	2,70	9,76	27,46	2,37						
Moduuli_222	25.4.17 23:17	18,66	17,09	2,62	9,36	26,46	2,22						
Moduuli_222	26.4.17 0:17	18,55	16,99	2,59	8,96	26,71	2,18				-13,12	81,80	1,30
Moduuli_222	26.4.17 1:17	18,44	16,89	2,56	8,74	26,89	2,16	-14,46			-13,96	80,65	1,20
Moduuli_222	26.4.17 2:17	18,34	16,79	2,53	8,58	26,87	2,14	-15,26			-14,90	81,06	1,12
Moduuli_222	26.4.17 3:17	18,25	16,70	2,50	8,45	26,71	2,11				-14,80	81,75	1,14
Moduuli_222	26.4.17 4:17	18,18	16,61	2,47	8,32	26,63	2,08	-15,20			-14,48	82,00	1,17
Moduuli_222	26.4.17 5:17	18,14	16,79	2,49	8,34	28,12	2,20	-4,44	87,77	2,76	-2,10	84,27	3,15
Moduuli_222	26.4.17 6:17	18,28	17,62	2,64	9,58	27,53	2,35				-13,40	79,60	1,24
Moduuli_222	26.4.17 7:17	18,32	17,24	2,59	9,16	26,55	2,20	-14,14					
Moduuli_222	26.4.17 8:17	18,32	17,14	2,58	8,79	27,03	2,18				-13,00	82,05	1,32
Moduuli_222	26.4.17 9:17	18,40	17,14	2,59	8,64	27,43	2,19						
Moduuli_222	26.4.17 10:17	18,49	17,10	2,60	8,58	27,47	2,19	-15,12	86,27	1,17	-14,76	81,57	1,14
Moduuli_222	26.4.17 11:17	18,66	17,09	2,62	8,60	27,54	2,20	-15,01	86,82	1,19	-14,40	82,10	1,18
Moduuli_222	26.4.17 12:17	18,79	17,06	2,64	8,60	27,48	2,19				-14,00	82,34	1,22
Moduuli_222	26.4.17 13:17	18,86	17,05	2,65	8,62	28,39	2,27	-5,92	88,65	2,49	-3,56	84,91	2,85
Moduuli_222	26.4.17 14:17	19,13	17,82	2,82	9,86	28,25	2,45	-13,04	82,75	1,33	-13,18	79,91	1,27
Moduuli_222	26.4.17 15:17	19,18	17,45	2,77	9,60	27,16	2,32						
Moduuli_222	26.4.17 16:17	19,19	17,25	2,74	9,31	27,38	2,29				-13,14	82,47	1,31
Moduuli_222	26.4.17 17:17	19,11	17,16	2,71	9,14	27,46	2,27				-13,85	81,52	1,22
Moduuli_222	26.4.17 18:17	19,04	17,01	2,67	9,04	27,33	2,25				-14,90		
Moduuli_222	26.4.17 19:17	18,93	16,88	2,63	8,88	27,06	2,20				-14,73	82,41	1,15
Moduuli_222	26.4.17 20:17	18,84	16,75	2,60	8,78	26,84	2,17	-15,16	87,36	1,18	-14,34	82,65	1,19

Moduuli_222	26.4.17 21:17	18,78	16,73	2,59	8,70	27,79	2,23	-5,82	88,82	2,51	-3,44	85,09	2,88
Moduuli_222	26.4.17 22:17	18,84	17,47	2,71	9,82	27,54	2,38	-12,98	82,86	1,34	-13,12	80,03	1,28
Moduuli_222	26.4.17 23:17	18,79	17,06	2,64	9,42	26,47	2,23				-14,12	82,16	1,21
Moduuli_222	27.4.17 0:17	18,66	16,92	2,60	9,02	26,66	2,19				-13,30	82,52	1,30
Moduuli_222	27.4.17 1:17	18,58	16,87	2,57	8,82	26,98	2,18				-13,28		
Moduuli_222	27.4.17 2:17	18,51	16,78	2,55	8,67	26,96	2,16						
Moduuli_222	27.4.17 3:17	18,44	16,76	2,54	8,54	26,83	2,13	-15,42			-14,88	82,16	1,13
Moduuli_222	27.4.17 4:17	18,35	16,66	2,51	8,44	26,73	2,11				-14,54	82,47	1,17
Moduuli_222	27.4.17 5:17	18,28	16,77	2,51	8,43	28,05	2,21	-4,74	88,59	2,72	-2,38	84,84	3,11
Moduuli_222	27.4.17 6:17	18,41	17,66	2,67	9,69	27,63	2,37	-12,80	82,14	1,34	-13,04	79,98	1,28
Moduuli_222	27.4.17 7:17	18,44	17,21	2,61	9,27	26,55	2,22				-14,02	82,19	1,22
Moduuli_222	27.4.17 8:17	18,42	17,14	2,59	8,88	26,97	2,19				-13,16	82,37	1,31
Moduuli_222	27.4.17 9:17	18,48	17,10	2,59	8,70	27,38	2,20	-14,42			-13,98	81,18	1,21
Moduuli_222	27.4.17 10:17	18,65	17,15	2,63	8,67	27,56	2,21	-15,16					
Moduuli_222	27.4.17 12:17	19,10	17,09	2,70	8,76	27,72	2,23						
Moduuli_222	27.4.17 13:17	19,24	17,11	2,72	8,80	28,45	2,30	-6,38	88,98	2,41	-4,06	85,19	2,75
Moduuli_222	27.4.17 14:17	19,55	17,89	2,90	10,08	28,47	2,51	-12,74	83,37	1,37	-12,84	80,27	1,31
Moduuli_222	27.4.17 15:17	19,62	17,45	2,84	9,84	27,27	2,36	-14,36	86,27	1,24	-14,09	82,32	1,21
Moduuli_222	27.4.17 16:17	19,74	17,29	2,84	9,59	27,54	2,35	-13,90	87,31	1,31	-13,14	82,71	1,32
Moduuli_222	27.4.17 17:17	19,75	17,17	2,82	9,49	27,63	2,34	-14,60			-14,13	81,53	1,20
Moduuli_222	27.4.17 18:17	19,78	17,08	2,81	9,41	27,48	2,31	-15,18			-14,74		
Moduuli_222	27.4.17 19:17	19,83	16,96	2,80	9,38	27,34	2,30						
Moduuli_222	27.4.17 20:17	19,82	16,79	2,77	9,36	27,09	2,27				-13,80	83,09	1,25
Moduuli_222	27.4.17 21:17	19,68	16,68	2,73	9,23	27,61	2,30	-6,32	89,33	2,43	-3,98	85,55	2,78
Moduuli_222	27.4.17 22:17	19,64	17,39	2,84	10,36	27,53	2,47	-12,77	83,46	1,37	-12,86	80,43	1,31
Moduuli_222	27.4.17 23:17	19,45	16,94	2,73	9,94	26,29	2,29				-14,09	82,49	1,22
Moduuli_222	28.4.17 0:17	19,19	16,79	2,66	9,44	26,42	2,23	-13,94	87,02	1,30	-13,16	82,76	1,31
Moduuli_222	28.4.17 1:17	18,97	16,66	2,61	9,15	26,61	2,20	-14,54	86,40	1,23	-14,05	81,55	1,21
Moduuli_222	28.4.17 2:17	18,77	16,60	2,56	8,91	26,53	2,16						
Moduuli_222	28.4.17 3:17	18,60	16,48	2,52	8,72	26,38	2,12						
Moduuli_222	28.4.17 4:17	18,43	16,42	2,48	8,52	26,25	2,08	-15,12			-14,24	82,61	1,20
Moduuli_222	28.4.17 5:17	18,32	16,39	2,46	8,33	26,92	2,11	-6,92	88,90	2,31	-4,58	85,17	2,65
Moduuli_222	28.4.17 6:17	18,42	17,27	2,61	9,45	27,43	2,32	-12,50	83,01	1,39	-12,50	80,22	1,34
Moduuli_222	28.4.17 7:17	18,47	16,96	2,57	9,16	26,39	2,19						
Moduuli_222	28.4.17 8:17	18,20	16,75	2,50	8,77	26,40	2,13	-14,18	86,37	1,26	-13,53	82,18	1,27
Moduuli_222	28.4.17 9:17	18,08	16,81	2,49	8,46	26,80	2,12				-12,82	82,23	1,34
Moduuli_222	28.4.17 10:17	18,29	16,91	2,53	8,40	27,23	2,14	-14,90	85,86	1,18	-14,43	80,75	1,16
Moduuli_222	28.4.17 11:17	18,51	16,91	2,57	8,42	27,36	2,15						
Moduuli_222	28.4.17 12:17	18,68	16,96	2,61	8,48	27,38	2,17				-14,70	81,88	1,15
Moduuli_222	28.4.17 13:17	18,92	17,10	2,67	8,63	28,74	2,30	-5,14	88,80	2,65	-2,73	84,68	3,02
Moduuli_222	28.4.17 14:17	19,38	18,10	2,90	10,14	28,71	2,54	-12,06	83,05	1,44	-12,06	80,56	1,40
Moduuli_222	28.4.17 15:17	19,68	17,67	2,89	9,88	27,50	2,39				-13,49	82,36	1,27
Moduuli_222	28.4.17 16:17	19,81	17,55	2,89	9,62	27,98	2,39				-13,72	81,36	1,24
Moduuli_222	28.4.17 17:17	19,93	17,42	2,89	9,54	27,99	2,38	-14,90	87,09	1,20	-14,56	81,78	1,16
Moduuli_222	28.4.17 18:17	19,92	17,29	2,87	9,49	27,79	2,35				-13,86	82,34	1,24
Moduuli_222	28.4.17 19:17	19,90	17,08	2,83	9,44	27,61	2,33	-14,21	88,07	1,28	-13,14	82,52	1,31
Moduuli_222	28.4.17 20:17	19,87	16,94	2,80	9,40	27,48	2,31				-13,28	82,04	1,29
Moduuli_222	28.4.17 21:17	19,75	16,84	2,76	9,28	28,00	2,34	-5,76	89,46	2,54	-3,38	85,04	2,89
Moduuli_222	28.4.17 22:17	19,73	17,68	2,90	10,54	27,93	2,54	-12,20	83,45	1,43	-12,22	80,29	1,38
Moduuli_222	28.4.17 23:17	19,61	17,25	2,81	10,09	26,59	2,34						
Moduuli_222	29.4.17 0:17	19,38	17,12	2,75	9,58	26,90	2,29				-12,81	82,28	1,35
Moduuli_222	29.4.17 1:17	19,17	17,02	2,70	9,28	27,06	2,26	-14,94	86,49	1,19	-14,68	80,81	1,13
Moduuli_222	29.4.17 2:17	18,98	16,92	2,65	9,04	26,95	2,21				-14,61	81,67	1,15
Moduuli_222	29.4.17 3:17	18,80	16,80	2,60	8,85	26,86	2,18	-14,88			-14,11	81,97	1,21
Moduuli_222	29.4.17 4:17	18,65	16,69	2,56	8,68	26,75	2,14				-13,60	81,99	1,26
Moduuli_222	29.4.17 5:17	18,49	16,64	2,53	8,45	27,34	2,16	-6,79	89,13	2,34	-4,45	84,63	2,66
Moduuli_222	29.4.17 6:17	18,51	17,53	2,66	9,60	27,79	2,37	-12,10			-12,04	79,88	1,39
Moduuli_222	29.4.17 7:17	18,48	17,16	2,60	9,24	26,58	2,21				-14,28		
Moduuli_222	29.4.17 8:17	18,48	17,10	2,59	8,84	26,92	2,18				-13,52	81,52	1,26
Moduuli_222	29.4.17 9:17	18,50	17,10	2,60	8,66	27,37	2,19	-13,82			-12,92	81,39	1,32
Moduuli_222	29.4.17 10:17	18,55	17,09	2,60	8,58	27,53	2,19				-14,78	80,19	1,12
Moduuli_222	29.4.17 11:17	18,62	17,07	2,61	8,54	27,49	2,18						
Moduuli_222	29.4.17 12:17	18,67	16,99	2,61	8,53	27,39	2,17				-14,45	81,38	1,16

Moduuli_222	29.4.17 13:17	18,68	16,93	2,60	8,44	27,80	2,19	-7,60	89,07	2,20	-5,30	84,31	2,48
Moduuli_222	29.4.17 14:17	18,79	17,78	2,75	9,62	28,36	2,42	-11,98	83,78	1,46	-11,81	79,90	1,42
Moduuli_222	29.4.17 15:17	18,87	17,42	2,71	9,37	27,12	2,28						
Moduuli_222	29.4.17 16:17	18,82	17,27	2,68	9,02	27,29	2,24						
Moduuli_222	29.4.17 17:17	18,77	17,15	2,65	8,84	27,46	2,23				-12,84	81,59	1,33
Moduuli_222	29.4.17 18:17	18,74	17,08	2,63	8,74	27,52	2,22				-14,44	80,08	1,15
Moduuli_222	29.4.17 19:17	18,68	16,96	2,61	8,64	27,36	2,19						
Moduuli_222	29.4.17 20:17	18,61	16,88	2,58	8,54	27,11	2,15				-14,83	81,21	1,13
Moduuli_222	29.4.17 21:17	18,55	16,86	2,57	8,48	28,03	2,22	-5,73	89,04	2,54	-3,34	84,15	2,87
Moduuli_222	29.4.17 22:17	18,62	17,86	2,73	9,84	28,18	2,44	-11,76	82,83	1,47	-11,77	79,71	1,42
Moduuli_222	29.4.17 23:17	18,59	17,39	2,66	9,43	26,73	2,25	-14,30	85,38	1,24	-14,12	81,19	1,19
Moduuli_222	30.4.17 0:17	18,50	17,23	2,62	8,98	27,06	2,21	-13,82			-13,18	81,38	1,29
Moduuli_222	30.4.17 1:17	18,42	17,14	2,59	8,73	27,36	2,20						
Moduuli_222	30.4.17 2:17	18,36	17,12	2,58	8,56	27,34	2,17	-15,16	86,54	1,17			
Moduuli_222	30.4.17 3:17	18,32	17,05	2,56	8,46	27,24	2,15						
Moduuli_222	30.4.17 4:17	18,28	16,97	2,54	8,36	27,21	2,13				-14,12	81,33	1,20
Moduuli_222	30.4.17 5:17	18,23	16,89	2,52	8,21	27,61	2,14	-7,64	88,91	2,19	-5,34	84,20	2,47
Moduuli_222	30.4.17 6:17	18,34	17,77	2,67	9,40	28,32	2,38	-11,72	83,84	1,50	-11,50	80,10	1,45
Moduuli_222	30.4.17 7:17	18,36	17,42	2,62	9,13	27,01	2,23						
Moduuli_222	30.4.17 8:17	18,33	17,28	2,60	8,76	27,21	2,19	-14,28	86,58	1,26	-13,72	81,36	1,24
Moduuli_222	30.4.17 9:17	18,32	17,18	2,58	8,57	27,47	2,19				-12,94	81,51	1,32
Moduuli_222	30.4.17 10:17	18,38	17,20	2,59	8,50	27,70	2,19						
Moduuli_222	30.4.17 11:17	18,45	17,15	2,60	8,46	27,68	2,19				-14,94	80,68	1,11
Moduuli_222	30.4.17 12:17	18,53	17,11	2,60	8,44	27,55	2,17						
Moduuli_222	30.4.17 13:17	18,60	17,07	2,61	8,44	28,27	2,23	-6,70	89,14	2,36	-4,36	84,26	2,66
Moduuli_222	30.4.17 14:17	18,87	18,07	2,81	9,80	28,73	2,48	-11,53	83,85	1,52	-11,38	80,45	1,48
Moduuli_222	30.4.17 15:17	18,96	17,64	2,76	9,54	27,33	2,32				-14,22	81,30	1,18
Moduuli_222	30.4.17 16:17	19,07	17,51	2,76	9,22	27,67	2,30	-13,88	86,87	1,30	-13,26	81,80	1,29
Moduuli_222	30.4.17 17:17	19,10	17,42	2,75	9,08	27,94	2,30				-13,96	80,70	1,20
Moduuli_222	30.4.17 18:17	19,09	17,29	2,72	9,00	27,79	2,28						
Moduuli_222	30.4.17 19:17	19,01	17,16	2,69	8,88	27,53	2,24						
Moduuli_222	30.4.17 20:17	18,90	16,97	2,64	8,80	27,32	2,21				-13,70	82,29	1,25
Moduuli_222	30.4.17 21:17	18,78	16,86	2,61	8,60	27,57	2,20	-7,54	89,20	2,21	-5,24	84,96	2,51
Moduuli_222	30.4.17 22:17	18,78	17,71	2,74	9,77	28,22	2,43	-11,56	84,04	1,52	-11,41	80,72	1,48
Moduuli_222	30.4.17 23:17	18,70	17,30	2,66	9,45	26,74	2,26				-14,28	81,67	1,18
Moduuli_223	14.4.17 0:11	-13,42	74,34	1,16	-12,60	76,84	1,28	8,85	21,50	1,74	19,10	13,93	2,20
Moduuli_223	14.4.17 1:11	-12,17	74,98	1,29	-11,98	77,51	1,35	8,60	21,42	1,71	18,94	13,75	2,15
Moduuli_223	14.4.17 2:11	-13,44	74,33	1,15	-12,88	77,35	1,26	8,41	21,36	1,68	18,80	13,64	2,11
Moduuli_223	14.4.17 3:11	-12,46	74,82	1,26	-12,46	77,66	1,31	8,24	21,21	1,65	18,66	13,50	2,07
Moduuli_223	14.4.17 4:11	-13,68	73,29	1,12	-13,16	76,69	1,22	8,08	21,10	1,62	18,54	13,39	2,04
Moduuli_223	14.4.17 5:11	1,62	74,72	3,66	-0,60	77,97	3,26	8,32	22,96	1,80	18,48	13,54	2,05
Moduuli_223	14.4.17 6:11	-11,64	74,69	1,34	-10,78	74,89	1,44	9,19	21,60	1,79	18,52	14,01	2,13
Moduuli_223	14.4.17 7:11	-12,64	74,84	1,24	-11,92	75,75	1,33	8,78	20,90	1,69	18,48	13,77	2,09
Moduuli_223	14.4.17 8:11	-13,54	73,66	1,13	-12,64	75,72	1,25	8,42	21,07	1,66	18,45	13,63	2,06
Moduuli_223	14.4.17 9:11	-12,56	74,51	1,24	-12,18	76,59	1,32	8,20	21,13	1,64	18,43	13,52	2,05
Moduuli_223	14.4.17 10:11	-13,60	73,16	1,12	-12,90	76,12	1,24	8,06	21,22	1,63	18,43	13,46	2,04
Moduuli_223	14.4.17 11:11	-13,04	74,18	1,19	-12,78	76,91	1,26	8,00	21,20	1,62	18,45	13,46	2,04
Moduuli_223	14.4.17 12:11	-12,20	73,91	1,27	-12,32	76,88	1,31	7,94	21,24	1,62	18,57	13,44	2,05
Moduuli_223	14.4.17 13:11	1,18	74,50	3,54	-1,04	77,88	3,15	8,24	23,06	1,79	18,73	13,65	2,10
Moduuli_223	14.4.17 14:11	-11,64	74,34	1,34	-10,84	75,05	1,44	9,24	21,94	1,83	19,00	14,17	2,22
Moduuli_223	14.4.17 15:11	-12,62	74,49	1,24	-11,93	76,07	1,33	9,03	21,39	1,76	19,24	13,98	2,22
Moduuli_223	14.4.17 16:11	-13,43	73,57	1,14	-12,59	76,34	1,27	8,82	21,45	1,74	19,28	13,86	2,21
Moduuli_223	14.4.17 17:11	-12,28	74,39	1,27	-12,06	77,26	1,34	8,70	21,48	1,72	19,34	13,74	2,20
Moduuli_223	14.4.17 18:11	-13,50	73,63	1,14	-12,93	77,18	1,25	8,62	21,46	1,71	19,30	13,66	2,18
Moduuli_223	14.4.17 19:11	-12,52	74,16	1,24	-12,54	77,63	1,30	8,52	21,20	1,68	19,20	13,50	2,14
Moduuli_223	14.4.17 20:11	-13,60	72,45	1,11	-13,08	76,66	1,23	8,43	21,14	1,67	19,12	13,41	2,12
Moduuli_223	14.4.17 21:11	1,52	74,27	3,62	-0,74	78,05	3,23	8,64	22,68	1,81	19,00	13,50	2,12
Moduuli_223	14.4.17 22:11	-11,60	74,05	1,33	-10,74	74,88	1,44	9,53	21,42	1,82	19,00	13,90	2,18
Moduuli_223	14.4.17 23:11	-12,58	74,04	1,23	-11,88	75,63	1,33	9,10	20,64	1,70	18,91	13,61	2,12
Moduuli_223	15.4.17 0:11	-13,44	72,98	1,13	-12,56	75,62	1,26	8,70	20,71	1,66	18,77	13,43	2,07
Moduuli_223	15.4.17 1:11	-12,24	73,64	1,26	-11,99	76,35	1,33	8,44	20,69	1,63	18,66	13,33	2,05
Moduuli_223	15.4.17 2:11	-13,52	72,83	1,12	-12,88	76,10	1,24	8,24	20,73	1,61	18,56	13,23	2,02
Moduuli_223	15.4.17 3:11	-12,60	73,32	1,22	-12,52	76,44	1,28	8,09	20,62	1,59	18,48	13,14	1,99

Moduuli_223	15.4.17 4:11	-13,58	71,40	1,10	-13,04	75,34	1,21	7,96	20,61	1,57	18,42	13,06	1,97
Moduuli_223	15.4.17 5:11	1,27	73,78	3,53	-0,98	77,29	3,14	8,16	22,21	1,72	18,37	13,17	1,98
Moduuli_223	15.4.17 6:11	-11,62	73,43	1,32	-10,76	74,06	1,43	9,10	21,16	1,75	18,43	13,72	2,08
Moduuli_223	15.4.17 7:11	-12,88	73,39	1,19	-12,06	74,76	1,30	8,72	20,40	1,64	18,39	13,45	2,03
Moduuli_223	15.4.17 8:11	-13,48	71,79	1,11	-12,54	74,49	1,24	8,36	20,57	1,61	18,35	13,30	2,00
Moduuli_223	15.4.17 9:11	-12,78	73,04	1,20	-12,32	75,64	1,29	8,14	20,67	1,60	18,34	13,26	1,99
Moduuli_223	15.4.17 10:11	-13,38	71,44	1,12	-12,69	75,00	1,24	8,01	20,75	1,59	18,36	13,17	1,98
Moduuli_223	15.4.17 11:11	-13,28	72,70	1,14	-12,90	75,91	1,23	7,94	20,79	1,59	18,42	13,19	1,99
Moduuli_223	15.4.17 12:11	-12,28	72,76	1,24	-12,42	75,97	1,28	7,93	20,79	1,58	18,54	13,16	2,00
Moduuli_223	15.4.17 13:11	0,86	73,73	3,42	-1,38	77,32	3,05	8,20	22,38	1,74	18,71	13,35	2,05
Moduuli_223	15.4.17 14:11	-11,73	73,32	1,31	-10,90	74,22	1,41	9,24	21,52	1,79	18,96	13,89	2,17
Moduuli_223	15.4.17 15:11	-12,88	73,41	1,19	-12,09	75,16	1,30	9,02	20,88	1,71	19,11	13,67	2,16
Moduuli_223	15.4.17 16:11	-13,40	72,15	1,12	-12,52	75,13	1,26	8,78	21,06	1,70	19,26	13,55	2,16
Moduuli_223	15.4.17 17:11	-12,58	73,48	1,22	-12,23	76,43	1,31	8,68	21,03	1,69	19,29	13,46	2,15
Moduuli_223	15.4.17 18:11	-13,53	72,37	1,12	-12,88	76,12	1,24	8,64	21,14	1,69	19,36	13,42	2,15
Moduuli_223	15.4.17 19:11	-12,80	73,52	1,20	-12,66	76,94	1,27	8,59	20,97	1,67	19,39	13,33	2,14
Moduuli_223	15.4.17 20:11	-13,22	71,85	1,14	-12,82	75,99	1,24	8,53	20,79	1,65	19,30	13,20	2,11
Moduuli_223	15.4.17 21:11	1,31	74,10	3,55	-0,98	77,75	3,16	8,73	22,23	1,79	19,20	13,30	2,11
Moduuli_223	15.4.17 22:11	-11,57	73,80	1,33	-10,72	74,43	1,44	9,68	21,15	1,81	19,20	13,76	2,18
Moduuli_223	15.4.17 23:11	-12,68	73,88	1,22	-11,94	75,26	1,32	9,26	20,31	1,69	19,10	13,40	2,11
Moduuli_223	16.4.17 0:11	-13,47	72,82	1,13	-12,60	75,20	1,25	8,84	20,37	1,65	18,96	13,23	2,07
Moduuli_223	16.4.17 1:11	-12,36	73,65	1,25	-12,06	75,98	1,32	8,56	20,35	1,62	18,81	13,11	2,03
Moduuli_223	16.4.17 2:11	-13,52	72,86	1,12	-12,90	75,76	1,23	8,36	20,35	1,60	18,69	13,01	2,00
Moduuli_223	16.4.17 3:11	-12,66	73,43	1,22	-12,56	76,15	1,27	8,20	20,23	1,57	18,57	12,90	1,97
Moduuli_223	16.4.17 4:11	-13,44	71,52	1,11	-12,96	75,01	1,21	8,04	20,22	1,55	18,52	12,82	1,95
Moduuli_223	16.4.17 5:11	1,02	73,93	3,47	-1,24	77,13	3,07	8,20	21,71	1,68	18,44	12,93	1,96
Moduuli_223	16.4.17 6:11	-11,60	73,59	1,33	-10,72	73,71	1,42	9,18	20,89	1,73	18,50	13,55	2,06
Moduuli_223	16.4.17 7:11	-12,86	73,65	1,20	-12,04	74,47	1,30	8,78	20,09	1,62	18,46	13,27	2,01
Moduuli_223	16.4.17 8:11	-13,50	72,02	1,11	-12,52	74,19	1,24	8,41	20,24	1,59	18,42	13,12	1,98
Moduuli_223	16.4.17 9:11	-12,81	73,31	1,20	-12,31	75,34	1,28	8,17	20,35	1,58	18,38	13,04	1,97
Moduuli_223	16.4.17 10:11	-13,32	71,82	1,13	-12,62	74,77	1,24	8,04	20,44	1,57	18,39	13,05	1,97
Moduuli_223	16.4.17 11:11	-13,22	73,13	1,16	-12,86	75,70	1,23	8,00	20,49	1,57	18,44	13,00	1,97
Moduuli_223	16.4.17 12:11	-12,22	73,21	1,26	-12,38	75,78	1,28	7,96	20,48	1,56	18,52	12,96	1,97
Moduuli_223	16.4.17 13:11	0,57	74,13	3,37	-1,62	77,22	2,99	8,16	21,89	1,69	18,61	13,12	2,01
Moduuli_223	16.4.17 14:11	-11,72	73,65	1,31	-10,84	73,93	1,42	9,18	21,22	1,76	18,77	13,70	2,12
Moduuli_223	16.4.17 15:11	-12,98	73,76	1,19	-12,14	74,84	1,29	8,94	20,59	1,68	18,97	13,49	2,11
Moduuli_223	16.4.17 16:11	-13,38	72,52	1,13	-12,50	74,83	1,25	8,68	20,77	1,67	19,06	13,39	2,11
Moduuli_223	16.4.17 17:11	-12,54	73,85	1,23	-12,18	76,12	1,31	8,57	20,80	1,66	19,14	13,35	2,11
Moduuli_223	16.4.17 18:11	-13,53	72,85	1,12	-12,86	75,85	1,23	8,50	20,84	1,65	19,11	13,24	2,09
Moduuli_223	16.4.17 19:11	-12,74	73,86	1,21	-12,60	76,56	1,27	8,42	20,66	1,63	19,06	13,12	2,06
Moduuli_223	16.4.17 20:11	-13,36	72,11	1,13	-12,89	75,57	1,23	8,33	20,56	1,61	19,01	13,04	2,05
Moduuli_223	16.4.17 21:11	0,78	74,40	3,43	-1,42	77,58	3,05	8,50	21,87	1,73	18,92	13,15	2,05
Moduuli_223	16.4.17 22:11	-11,76	74,05	1,32	-10,82	74,14	1,42	9,48	21,09	1,78	18,92	13,64	2,13
Moduuli_223	16.4.17 23:11	-12,80	74,18	1,21	-12,00	74,99	1,31	9,08	20,19	1,66	18,84	13,32	2,07
Moduuli_223	17.4.17 0:11	-13,49	72,89	1,13	-12,58	74,80	1,25	8,67	20,25	1,62	18,70	13,14	2,02
Moduuli_223	17.4.17 1:11	-12,50	73,97	1,24	-12,14	75,78	1,31	8,38	20,29	1,59	18,58	13,04	1,99
Moduuli_223	17.4.17 2:11	-13,54	72,90	1,12	-12,86	75,37	1,23	8,20	20,33	1,58	18,48	12,94	1,96
Moduuli_223	17.4.17 3:11	-12,78	73,83	1,21	-12,60	75,96	1,26	8,04	20,25	1,55	18,40	12,92	1,95
Moduuli_223	17.4.17 4:11	-13,20	72,16	1,14	-12,76	75,00	1,23	7,93	20,21	1,54	18,34	12,83	1,93
Moduuli_223	17.4.17 5:11	0,60	74,42	3,39	-1,58	77,15	3,00	8,05	21,57	1,66	18,28	12,95	1,94
Moduuli_223	17.4.17 6:11	-11,88	73,96	1,30	-10,88	73,66	1,41	9,06	20,95	1,72	18,32	13,56	2,04
Moduuli_223	17.4.17 7:11	-13,04	74,00	1,19	-12,16	74,43	1,28	8,67	20,12	1,61	18,31	13,29	1,99
Moduuli_223	17.4.17 8:11	-13,32	72,48	1,14	-12,40	74,15	1,25	8,31	20,27	1,58	18,30	13,15	1,97
Moduuli_223	17.4.17 9:11	-12,89	73,74	1,20	-12,36	75,38	1,28	8,10	20,40	1,57	18,28	13,08	1,96
Moduuli_223	17.4.17 10:11	-13,34	72,22	1,13	-12,66	74,75	1,24	7,98	20,49	1,57	18,32	13,06	1,96
Moduuli_223	17.4.17 11:11	-13,22	73,43	1,16	-12,86	75,70	1,23	7,92	20,53	1,56	18,37	13,04	1,96
Moduuli_223	17.4.17 12:11	-12,17	73,46	1,26	-12,35	75,74	1,28	7,90	20,56	1,56	18,47	13,01	1,97
Moduuli_223	17.4.17 13:11	0,24	74,28	3,30	-1,92	77,20	2,93	8,08	21,86	1,68	18,58	13,11	2,00
Moduuli_223	17.4.17 14:11	-11,84	73,67	1,30	-10,88	73,87	1,41	9,19	21,38	1,77	18,82	13,74	2,13
Moduuli_223	17.4.17 15:11	-12,96	73,77	1,19	-12,10	74,80	1,29	8,96	20,63	1,69	18,99	13,53	2,12
Moduuli_223	17.4.17 16:11	-13,23	72,61	1,15	-12,44	74,77	1,26	8,70	20,71	1,66	19,04	13,38	2,10
Moduuli_223	17.4.17 17:11	-12,26	73,84	1,26	-12,00	76,07	1,33	8,57	20,80	1,66	19,13	13,35	2,11
Moduuli_223	17.4.17 18:11	-13,42	73,12	1,14	-12,85	76,03	1,24	8,47	20,77	1,64	19,10	13,24	2,09



Moduuli_223	17.4.17 19:11	-12,44	73,63	1,24	-12,44	76,46	1,29	8,38	20,61	1,62	19,04	13,12	2,06
Moduuli_223	17.4.17 20:11	-13,60	72,19	1,11	-13,10	75,65	1,21	8,32	20,53	1,61	18,97	13,03	2,04
Moduuli_223	17.4.17 21:11	0,60	74,01	3,37	-1,60	77,30	3,00	8,46	21,73	1,72	18,88	13,07	2,03
Moduuli_223	17.4.17 22:11	-11,82	73,47	1,30	-10,84	73,80	1,41	9,46	21,01	1,78	18,88	13,66	2,13
Moduuli_223	17.4.17 23:11	-12,93	73,47	1,19	-12,04	74,57	1,30	9,06	20,12	1,65	18,80	13,31	2,06
Moduuli_223	18.4.17 0:11	-13,48	72,00	1,11	-12,51	74,29	1,24	8,64	20,18	1,61	18,66	13,13	2,01
Moduuli_223	18.4.17 1:11	-12,62	73,14	1,21	-12,18	75,36	1,30	8,35	20,15	1,58	18,54	13,03	1,98
Moduuli_223	18.4.17 2:11	-13,60	71,70	1,10	-12,86	74,79	1,22	8,16	20,22	1,57	18,44	12,93	1,96
Moduuli_223	18.4.17 3:11	-12,98	72,77	1,17	-12,76	75,51	1,24	8,02	20,11	1,54	18,35	12,84	1,93
Moduuli_223	18.4.17 4:11	-12,34	72,28	1,23	-12,36	75,20	1,27	7,88	20,07	1,52	18,28	12,75	1,91
Moduuli_223	18.4.17 5:11	0,20	73,60	3,26	-1,99	76,77	2,90	7,98	21,19	1,62	18,22	12,80	1,91
Moduuli_223	18.4.17 6:11	-11,87	72,79	1,28	-10,88	73,10	1,40	9,01	20,87	1,71	18,27	13,41	2,01
Moduuli_223	18.4.17 7:11	-13,06	72,85	1,17	-12,16	73,82	1,27	8,64	19,99	1,60	18,26	13,14	1,97
Moduuli_223	18.4.17 8:11	-13,39	71,23	1,11	-12,40	73,49	1,24	8,26	20,09	1,57	18,23	13,06	1,95
Moduuli_223	18.4.17 9:11	-13,46	72,16	1,12	-12,74	74,60	1,23	8,02	20,18	1,55	18,20	12,99	1,94
Moduuli_223	18.4.17 10:11	-12,34	72,59	1,23	-12,22	75,12	1,29	7,90	20,27	1,54	18,26	12,94	1,94
Moduuli_223	18.4.17 11:11	-13,58	71,58	1,10	-13,04	74,81	1,20	7,90	20,49	1,56	18,49	12,95	1,97
Moduuli_223	18.4.17 12:11	-12,79	72,22	1,18	-12,70	75,27	1,24	7,95	20,57	1,57	18,75	13,03	2,01
Moduuli_223	18.4.17 13:11	-0,54	73,44	3,08	-2,65	76,94	2,76	8,22	21,75	1,69	19,08	13,13	2,07
Moduuli_223	18.4.17 14:11	-12,02	72,51	1,26	-11,01	73,70	1,39	9,44	21,59	1,82	19,50	13,79	2,23
Moduuli_223	18.4.17 15:11	-13,08	72,71	1,16	-12,20	74,62	1,28	9,22	20,49	1,70	19,35	13,41	2,15
Moduuli_223	18.4.17 16:11	-13,10	71,58	1,14	-12,30	74,64	1,27	9,00	20,74	1,70	19,66	13,38	2,18
Moduuli_223	18.4.17 17:11	-12,80	72,90	1,19	-12,34	76,07	1,29	8,96	20,86	1,70	19,87	13,38	2,21
Moduuli_223	18.4.17 18:11	-13,48	71,54	1,11	-12,82	75,69	1,24	8,93	20,78	1,69	19,83	13,23	2,18
Moduuli_223	18.4.17 19:11	-12,80	72,80	1,19	-12,66	76,57	1,27	8,88	20,54	1,67	19,78	13,08	2,15
Moduuli_223	18.4.17 20:11	-13,28	71,06	1,12	-12,86	75,57	1,23	8,80	20,36	1,65	19,70	12,96	2,12
Moduuli_223	18.4.17 21:11	0,34	73,46	3,29	-1,87	77,42	2,95	8,90	21,35	1,74	19,55	12,95	2,10
Moduuli_223	18.4.17 22:11	-11,83	72,72	1,29	-10,78	73,62	1,42	9,92	20,77	1,81	19,52	13,47	2,18
Moduuli_223	18.4.17 23:11	-12,94	72,81	1,18	-12,06	74,44	1,29	9,52	19,81	1,68	19,39	13,13	2,11
Moduuli_223	19.4.17 0:11	-13,42	71,37	1,11	-12,49	74,17	1,24	9,06	19,76	1,63	19,20	12,90	2,05
Moduuli_223	19.4.17 1:11	-12,46	72,50	1,22	-12,12	75,15	1,30	8,74	19,70	1,59	19,02	12,78	2,01
Moduuli_223	19.4.17 2:11	-13,56	71,43	1,10	-12,88	74,76	1,22	8,50	19,75	1,56	18,86	12,66	1,97
Moduuli_223	19.4.17 3:11	-12,74	72,15	1,19	-12,60	75,20	1,25	8,32	19,56	1,53	18,71	12,55	1,93
Moduuli_223	19.4.17 4:11	-13,44	70,18	1,09	-12,92	74,04	1,20	8,13	19,51	1,51	18,57	12,44	1,90
Moduuli_223	19.4.17 5:11	0,02	72,86	3,18	-2,16	76,38	2,85	8,18	20,58	1,59	18,49	12,48	1,89
Moduuli_223	19.4.17 6:11	-11,92	72,00	1,26	-10,86	72,51	1,39	9,22	20,39	1,70	18,52	13,12	2,00
Moduuli_223	19.4.17 7:11	-13,12	72,01	1,15	-12,18	73,20	1,26	8,84	19,44	1,58	18,49	12,88	1,96
Moduuli_223	19.4.17 8:11	-13,06	70,66	1,13	-12,18	73,05	1,26	8,46	19,54	1,54	18,47	12,74	1,93
Moduuli_223	19.4.17 9:11	-12,94	71,68	1,16	-12,38	74,16	1,26	8,23	19,73	1,53	18,48	12,68	1,92
Moduuli_223	19.4.17 10:11	-13,32	70,12	1,10	-12,62	73,55	1,22	8,12	19,86	1,53	18,54	12,66	1,93
Moduuli_223	19.4.17 11:11	-13,18	71,45	1,13	-12,82	74,53	1,22	8,08	19,94	1,53	18,67	12,67	1,95
Moduuli_223	19.4.17 12:11	-12,14	71,44	1,23	-12,30	74,59	1,27	8,06	19,93	1,53	18,78	12,64	1,95
Moduuli_223	19.4.17 13:11	-0,24	72,70	3,12	-2,38	76,29	2,80	8,28	21,09	1,65	19,02	12,78	2,01
Moduuli_223	19.4.17 14:11	-11,94	71,84	1,26	-10,86	72,77	1,39	9,49	20,99	1,78	19,34	13,48	2,16
Moduuli_223	19.4.17 15:11	-12,99	72,07	1,16	-12,09	73,82	1,28	9,31	19,97	1,67	19,30	13,10	2,09
Moduuli_223	19.4.17 16:11	-13,32	70,66	1,11	-12,40	73,69	1,25	8,94	20,05	1,64	19,33	13,01	2,08
Moduuli_223	19.4.17 17:11	-12,44	71,94	1,21	-12,08	74,96	1,30	8,82	20,24	1,64	19,50	13,00	2,10
Moduuli_223	19.4.17 18:11	-13,40	71,23	1,11	-12,80	74,94	1,23	8,78	20,29	1,64	19,58	12,96	2,10
Moduuli_223	19.4.17 19:11	-12,42	71,84	1,21	-12,38	75,52	1,28	8,75	20,15	1,62	19,60	12,90	2,10
Moduuli_223	19.4.17 20:11	-13,48	70,58	1,09	-13,00	74,82	1,20	8,70	20,01	1,61	19,56	12,75	2,07
Moduuli_223	19.4.17 21:11	0,18	72,65	3,21	-2,00	76,61	2,89	8,80	21,00	1,70	19,46	12,75	2,06
Moduuli_223	19.4.17 22:11	-11,84	71,92	1,27	-10,75	72,88	1,41	9,90	20,64	1,80	19,46	13,38	2,16
Moduuli_223	19.4.17 23:11	-12,90	72,00	1,17	-12,02	73,71	1,28	9,52	19,59	1,66	19,35	13,02	2,08
Moduuli_223	20.4.17 0:11	-13,44	70,54	1,10	-12,44	73,53	1,24	9,06	19,57	1,61	19,20	12,77	2,03
Moduuli_223	20.4.17 1:11	-12,46	71,63	1,20	-12,06	74,51	1,29	8,76	19,57	1,58	19,04	12,65	1,99
Moduuli_223	20.4.17 2:11	-13,54	70,62	1,09	-12,86	74,16	1,21	8,54	19,57	1,55	18,90	12,54	1,95
Moduuli_223	20.4.17 3:11	-12,60	71,32	1,19	-12,48	74,66	1,25	8,35	19,44	1,52	18,78	12,44	1,92
Moduuli_223	20.4.17 4:11	-13,58	69,49	1,07	-13,04	73,57	1,18	8,18	19,39	1,50	18,65	12,33	1,89
Moduuli_223	20.4.17 5:11	-0,18	72,23	3,11	-2,33	75,90	2,79	8,22	20,31	1,58	18,54	12,36	1,88
Moduuli_223	20.4.17 6:11	-11,96	71,22	1,25	-10,84	71,90	1,38	9,30	20,26	1,69	18,58	13,04	1,99
Moduuli_223	20.4.17 7:11	-13,10	71,22	1,14	-12,14	72,60	1,25	8,94	19,31	1,58	18,56	12,77	1,95
Moduuli_223	20.4.17 8:11	-13,18	69,69	1,11	-12,24	72,39	1,24	8,54	19,41	1,54	18,56	12,64	1,93
Moduuli_223	20.4.17 9:11	-12,74	70,97	1,17	-12,22	73,65	1,26	8,31	19,56	1,53	18,60	12,62	1,93

Moduuli_223	20.4.17 10:11	-13,50	69,46	1,07	-12,74	73,13	1,20	8,20	19,72	1,53	18,65	12,60	1,93
Moduuli_223	20.4.17 11:11	-13,02	70,78	1,14	-12,72	74,10	1,22	8,16	19,71	1,53	18,74	12,56	1,94
Moduuli_223	20.4.17 12:11	-12,66	69,86	1,16	-12,44	73,68	1,24	8,16	19,80	1,53	18,92	12,55	1,96
Moduuli_223	20.4.17 13:11	-0,50	72,10	3,03	-2,63	75,80	2,73	8,34	20,79	1,63	19,07	12,66	1,99
Moduuli_223	20.4.17 14:11	-11,96	71,24	1,25	-10,82	72,09	1,38	9,50	20,64	1,75	19,12	13,28	2,10
Moduuli_223	20.4.17 15:11	-13,04	71,47	1,15	-12,08	73,08	1,27	9,28	19,80	1,65	19,32	13,07	2,09
Moduuli_223	20.4.17 16:11	-13,24	70,04	1,11	-12,30	73,03	1,24	8,98	19,84	1,62	19,33	12,91	2,07
Moduuli_223	20.4.17 17:11	-12,69	71,48	1,18	-12,20	74,37	1,28	8,79	19,84	1,60	19,28	12,80	2,04
Moduuli_223	20.4.17 18:11	-13,50	70,19	1,08	-12,78	73,95	1,21	8,65	19,86	1,59	19,22	12,71	2,02
Moduuli_223	20.4.17 19:11	-12,82	71,33	1,17	-12,56	74,73	1,25	8,52	19,69	1,56	19,11	12,61	1,99
Moduuli_223	20.4.17 20:11	-13,28	69,48	1,09	-12,80	73,67	1,21	8,40	19,62	1,54	19,04	12,52	1,97
Moduuli_223	20.4.17 21:11	-0,46	72,40	3,05	-2,62	76,01	2,74	8,45	20,44	1,61	18,93	12,49	1,95
Moduuli_223	20.4.17 22:11	-11,90	71,44	1,26	-10,74	72,06	1,39	9,54	20,46	1,74	18,94	13,15	2,05
Moduuli_223	20.4.17 23:11	-13,02	71,60	1,15	-12,05	72,93	1,27	9,17	19,35	1,60	18,86	12,83	1,99
Moduuli_223	21.4.17 0:11	-13,30	70,07	1,10	-12,34	72,72	1,23	8,77	19,38	1,56	18,75	12,66	1,95
Moduuli_223	21.4.17 1:11	-12,55	71,39	1,19	-12,08	73,90	1,28	8,48	19,42	1,54	18,63	12,53	1,92
Moduuli_223	21.4.17 2:11	-13,52	70,21	1,08	-12,76	73,48	1,21	8,30	19,49	1,52	18,57	12,51	1,91
Moduuli_223	21.4.17 3:11	-12,66	71,20	1,18	-12,48	74,15	1,24	8,15	19,45	1,50	18,52	12,42	1,89
Moduuli_223	21.4.17 4:11	-13,41	69,41	1,08	-12,88	73,08	1,19	8,04	19,41	1,49	18,47	12,34	1,87
Moduuli_223	21.4.17 5:11	-0,60	72,25	3,02	-2,72	75,57	2,70	8,12	20,34	1,57	18,42	12,39	1,87
Moduuli_223	21.4.17 6:11	-12,04	71,37	1,24	-10,82	71,63	1,37	9,24	20,46	1,70	18,54	13,09	1,99
Moduuli_223	21.4.17 7:11	-13,19	71,45	1,13	-12,14	72,47	1,25	8,92	19,43	1,58	18,54	12,83	1,95
Moduuli_223	21.4.17 8:11	-12,98	70,22	1,13	-12,08	72,49	1,26	8,55	19,57	1,56	18,61	12,72	1,95
Moduuli_223	21.4.17 9:11	-12,89	71,36	1,16	-12,28	73,73	1,26	8,40	19,78	1,56	18,76	12,73	1,97
Moduuli_223	21.4.17 10:11	-13,36	69,97	1,09	-12,60	73,32	1,22	8,36	19,96	1,57	18,92	12,75	1,99
Moduuli_223	21.4.17 11:11	-12,92	71,51	1,16	-12,60	74,42	1,24	8,35	19,96	1,56	19,02	12,68	1,99
Moduuli_223	21.4.17 12:11	-13,10	70,03	1,12	-12,63	73,67	1,22	8,38	20,00	1,57	19,20	12,70	2,02
Moduuli_223	21.4.17 13:11	-0,81	72,76	2,99	-2,93	76,01	2,67	8,32	20,24	1,58	18,48	12,48	1,89
Moduuli_223	21.4.17 14:11	-12,07	71,88	1,25	-10,82	71,96	1,38	9,42	20,75	1,75	18,96	13,29	2,08
Moduuli_223	21.4.17 15:11	-13,14	72,16	1,15	-12,10	73,12	1,27	9,28	19,96	1,67	19,40	13,17	2,12
Moduuli_223	21.4.17 16:11	-13,10	71,12	1,14	-12,15	73,41	1,27	9,11	20,23	1,67	19,74	13,07	2,15
Moduuli_223	21.4.17 17:11	-12,60	72,61	1,21	-12,10	75,03	1,30	9,12	20,46	1,69	20,08	13,11	2,20
Moduuli_223	21.4.17 18:11	-13,46	71,93	1,12	-12,74	75,16	1,24	9,18	20,48	1,70	20,25	13,03	2,21
Moduuli_223	21.4.17 19:11	-12,42	73,02	1,23	-12,30	76,00	1,29	9,22	20,36	1,69	20,39	12,94	2,21
Moduuli_223	21.4.17 20:11	-13,42	72,22	1,12	-12,94	75,60	1,22	9,24	20,17	1,68	20,36	12,83	2,19
Moduuli_223	21.4.17 21:11	-0,50	74,03	3,11	-2,70	77,36	2,77	9,36	20,95	1,76	20,29	12,85	2,18
Moduuli_223	21.4.17 22:11	-11,96	73,32	1,28	-10,70	73,31	1,42	10,49	20,69	1,87	20,22	13,39	2,26
Moduuli_223	21.4.17 23:11	-13,01	73,65	1,18	-12,00	74,38	1,30	10,08	19,47	1,72	19,96	12,94	2,15
Moduuli_223	22.4.17 0:11	-13,36	72,24	1,13	-12,34	74,14	1,26	9,55	19,37	1,65	19,69	12,72	2,08
Moduuli_223	22.4.17 1:11	-12,36	73,58	1,25	-11,96	75,23	1,32	9,18	19,32	1,60	19,42	12,54	2,02
Moduuli_223	22.4.17 2:11	-13,44	72,80	1,13	-12,74	74,90	1,23	8,90	19,29	1,57	19,22	12,41	1,97
Moduuli_223	22.4.17 3:11	-12,41	73,38	1,24	-12,32	75,19	1,28	8,65	19,15	1,53	19,04	12,32	1,94
Moduuli_223	22.4.17 4:11	-13,62	72,08	1,10	-13,04	74,30	1,19	8,44	19,09	1,51	18,86	12,20	1,90
Moduuli_223	22.4.17 5:11	-0,76	74,07	3,06	-2,90	76,38	2,69	8,42	19,92	1,57	18,72	12,15	1,87
Moduuli_223	22.4.17 6:11	-12,00	72,98	1,27	-10,72	72,04	1,39	9,52	20,23	1,72	18,79	12,94	2,00
Moduuli_223	22.4.17 7:11	-13,20	73,08	1,16	-12,14	72,96	1,26	9,18	19,19	1,59	18,83	12,65	1,96
Moduuli_223	22.4.17 8:11	-13,00	71,97	1,16	-12,08	72,95	1,26	8,78	19,26	1,55	18,83	12,52	1,94
Moduuli_223	22.4.17 9:11	-12,74	72,95	1,20	-12,18	74,12	1,27	8,56	19,45	1,55	18,82	12,52	1,94
Moduuli_223	22.4.17 10:11	-13,52	71,65	1,11	-12,71	73,70	1,21	8,44	19,54	1,54	18,88	12,47	1,94
Moduuli_223	22.4.17 11:11	-12,85	72,89	1,19	-12,54	74,56	1,25	8,38	19,55	1,54	18,96	12,46	1,95
Moduuli_223	22.4.17 12:11	-13,21	71,23	1,13	-12,70	73,65	1,21	8,35	19,57	1,53	18,99	12,41	1,94
Moduuli_223	22.4.17 13:11	-1,11	74,07	2,98	-3,22	76,28	2,63	8,44	20,37	1,61	19,06	12,46	1,96
Moduuli_223	22.4.17 14:11	-12,14	72,83	1,26	-10,81	72,17	1,39	9,66	20,76	1,78	19,30	13,20	2,11
Moduuli_223	22.4.17 15:11	-13,30	73,00	1,15	-12,19	73,20	1,26	9,44	19,69	1,66	19,44	12,98	2,09
Moduuli_223	22.4.17 16:11	-12,40	73,03	1,23	-11,76	74,07	1,32	9,16	19,86	1,64	19,60	12,90	2,10
Moduuli_223	22.4.17 17:11	-12,88	73,34	1,19	-12,28	74,90	1,28	9,04	19,98	1,64	19,72	12,83	2,10
Moduuli_223	22.4.17 18:11	-13,38	72,11	1,13	-12,62	74,49	1,24	8,97	19,96	1,63	19,70	12,73	2,08
Moduuli_223	22.4.17 19:11	-12,79	73,60	1,21	-12,52	75,48	1,26	8,91	19,81	1,61	19,66	12,65	2,07
Moduuli_223	22.4.17 20:11	-13,36	71,96	1,13	-12,80	74,51	1,22	8,82	19,69	1,59	19,58	12,52	2,03
Moduuli_223	22.4.17 21:11	-1,06	74,73	3,02	-3,21	76,99	2,65	8,82	20,36	1,65	19,46	12,52	2,02
Moduuli_223	22.4.17 22:11	-12,04	73,50	1,28	-10,74	72,66	1,40	9,93	20,55	1,79	19,44	13,18	2,12
Moduuli_223	22.4.17 23:11	-13,22	73,79	1,17	-12,16	73,59	1,27	9,57	19,34	1,65	19,33	12,81	2,05
Moduuli_223	23.4.17 0:11	-12,65	73,28	1,21	-11,89	73,90	1,30	9,13	19,37	1,60	19,20	12,64	2,01

Moduuli_223	23.4.17 1:11	-12,96	73,82	1,19	-12,33	74,71	1,27	8,82	19,40	1,57	19,07	12,53	1,97
Moduuli_223	23.4.17 2:11	-13,08	72,56	1,16	-12,42	74,12	1,25	8,62	19,47	1,55	18,98	12,44	1,95
Moduuli_223	23.4.17 3:11	-13,24	73,68	1,16	-12,80	74,94	1,23	8,46	19,42	1,53	18,94	12,39	1,93
Moduuli_223	23.4.17 4:11	-12,20	73,81	1,27	-12,32	74,91	1,27	8,34	19,38	1,52	18,86	12,33	1,92
Moduuli_223	23.4.17 5:11	-1,76	75,10	2,88	-3,86	76,71	2,52	8,30	19,94	1,56	18,80	12,31	1,91
Moduuli_223	23.4.17 6:11	-12,04	73,40	1,28	-10,80	72,30	1,39	9,42	20,49	1,73	18,85	12,99	2,02
Moduuli_223	23.4.17 7:11	-13,23	73,79	1,17	-12,18	73,25	1,26	9,15	19,37	1,60	18,87	12,73	1,98
Moduuli_223	23.4.17 8:11	-12,62	74,39	1,23	-12,05	74,31	1,29	8,76	19,35	1,56	18,85	12,63	1,96
Moduuli_223	23.4.17 9:11	-14,24	73,04	1,06	-13,17	74,03	1,18	8,52	19,63	1,56	18,87	12,53	1,95
Moduuli_223	23.4.17 10:11	-12,99	74,01	1,19	-12,56	74,96	1,25	8,38	19,65	1,54	18,89	12,51	1,95
Moduuli_223	23.4.17 11:11	-12,36	73,86	1,25	-12,25	75,03	1,28	8,33	19,76	1,55	18,98	12,50	1,96
Moduuli_223	23.4.17 12:11	-13,38	73,74	1,15	-12,98	74,98	1,21	8,34	19,80	1,55	19,14	12,49	1,97
Moduuli_223	23.4.17 13:11	-2,68	75,86	2,72	-4,71	77,28	2,38	8,44	20,31	1,60	19,34	12,55	2,01
Moduuli_223	23.4.17 14:11	-12,32	73,56	1,25	-11,04	72,89	1,37	9,62	20,94	1,79	19,60	13,26	2,16
Moduuli_223	23.4.17 15:11	-13,36	74,00	1,16	-12,28	73,96	1,26	9,52	19,88	1,69	19,76	13,01	2,14
Moduuli_223	23.4.17 16:11	-12,14	75,09	1,30	-11,78	75,36	1,34	9,26	19,92	1,66	19,86	12,91	2,13
Moduuli_223	23.4.17 17:11	-13,20	74,76	1,18	-12,56	75,77	1,26	9,18	20,09	1,67	20,03	12,90	2,15
Moduuli_223	23.4.17 18:11	-12,10	75,11	1,30	-11,98	76,26	1,33	9,14	20,08	1,66	20,02	12,80	2,14
Moduuli_223	23.4.17 19:11	-13,30	74,98	1,18	-12,86	76,28	1,24	9,06	19,86	1,63	19,92	12,66	2,10
Moduuli_223	23.4.17 20:11	-12,12	75,23	1,30	-12,31	76,30	1,30	8,94	19,63	1,60	19,79	12,49	2,06
Moduuli_223	23.4.17 21:11	-1,76	76,43	2,93	-3,86	77,93	2,56	8,90	20,13	1,64	19,59	12,43	2,02
Moduuli_223	23.4.17 22:11	-12,14	74,28	1,28	-10,82	73,09	1,40	9,97	20,56	1,80	19,52	13,07	2,12
Moduuli_223	23.4.17 23:11	-13,26	74,74	1,18	-12,20	74,01	1,27	9,64	19,27	1,65	19,36	12,75	2,04
Moduuli_223	24.4.17 0:11	-12,26	75,01	1,28	-11,72	74,77	1,33	9,13	19,21	1,59	19,17	12,53	1,98
Moduuli_223	24.4.17 1:11	-12,94	74,89	1,21	-12,36	75,10	1,27	8,80	19,23	1,55	19,00	12,44	1,95
Moduuli_223	24.4.17 2:11	-13,08	73,68	1,18	-12,42	74,45	1,26	8,55	19,25	1,53	18,82	12,32	1,91
Moduuli_223	24.4.17 3:11	-13,18	74,67	1,18	-12,78	75,17	1,23	8,34	19,18	1,50	18,66	12,27	1,88
Moduuli_223	24.4.17 4:11	-12,12	74,75	1,29	-12,28	75,10	1,28	8,18	19,13	1,48	18,57	12,17	1,86
Moduuli_223	24.4.17 5:11	-1,94	76,15	2,88	-4,03	77,04	2,50	8,12	19,76	1,53	18,54	12,17	1,85
Moduuli_223	24.4.17 6:11	-12,12	73,88	1,28	-10,82	72,37	1,39	9,26	20,50	1,71	18,62	12,92	1,98
Moduuli_223	24.4.17 7:11	-13,30	74,25	1,17	-12,22	73,29	1,26	9,02	19,33	1,59	18,70	12,68	1,95
Moduuli_223	24.4.17 8:11	-12,08	74,89	1,30	-11,66	74,38	1,33	8,64	19,44	1,55	18,72	12,62	1,94
Moduuli_223	24.4.17 9:11	-13,17	74,36	1,18	-12,50	74,68	1,25	8,47	19,64	1,55	18,82	12,55	1,95
Moduuli_223	24.4.17 10:11	-12,29	74,31	1,27	-12,00	74,94	1,31	8,38	19,74	1,55	18,87	12,53	1,95
Moduuli_223	24.4.17 11:11	-13,20	74,23	1,18	-12,78	75,20	1,23	8,36	19,77	1,55	18,98	12,57	1,97
Moduuli_223	24.4.17 12:11	-12,11	74,44	1,29	-12,24	75,34	1,29	8,31	19,56	1,53	18,83	12,42	1,93
Moduuli_223	24.4.17 13:11	-2,22	75,96	2,82	-4,26	77,27	2,46	8,30	20,20	1,58	18,96	12,50	1,95
Moduuli_223	24.4.17 14:11	-12,26	73,51	1,26	-10,84	72,60	1,39	9,58	21,12	1,80	19,30	13,30	2,12
Moduuli_223	24.4.17 15:11	-13,33	73,86	1,16	-12,18	73,61	1,27	9,45	19,85	1,68	19,45	13,05	2,10
Moduuli_223	24.4.17 16:11	-12,12	74,92	1,29	-11,69	75,14	1,34	9,18	20,03	1,66	19,68	12,99	2,12
Moduuli_223	24.4.17 17:11	-13,16	74,49	1,18	-12,44	75,56	1,27	9,06	20,12	1,65	19,75	12,88	2,11
Moduuli_223	24.4.17 18:11	-12,76	73,93	1,21	-12,22	75,45	1,29	8,98	20,09	1,64	19,72	12,80	2,10
Moduuli_223	24.4.17 19:11	-13,06	74,68	1,20	-12,68	76,08	1,26	8,88	19,93	1,62	19,66	12,72	2,08
Moduuli_223	24.4.17 20:11	-12,38	74,36	1,26	-12,30	75,90	1,29	8,81	19,78	1,60	19,59	12,56	2,04
Moduuli_223	24.4.17 21:11	-2,10	76,17	2,85	-4,17	77,81	2,49	8,76	20,22	1,63	19,47	12,52	2,02
Moduuli_223	24.4.17 22:11	-12,16	73,77	1,27	-10,74	72,86	1,41	9,90	20,86	1,82	19,46	13,25	2,14
Moduuli_223	24.4.17 23:11	-13,30	74,27	1,17	-12,18	73,91	1,27	9,60	19,45	1,66	19,36	12,89	2,07
Moduuli_223	25.4.17 0:11	-12,06	75,02	1,30	-11,62	75,06	1,35	9,13	19,43	1,61	19,20	12,70	2,02
Moduuli_223	25.4.17 1:11	-13,12	74,53	1,19	-12,43	75,21	1,27	8,81	19,46	1,57	19,06	12,56	1,98
Moduuli_223	25.4.17 2:11	-12,58	74,09	1,23	-12,12	75,02	1,30	8,59	19,46	1,55	18,92	12,48	1,95
Moduuli_223	25.4.17 3:11	-13,26	74,34	1,17	-12,81	75,31	1,23	8,41	19,40	1,53	18,79	12,38	1,91
Moduuli_223	25.4.17 4:11	-12,22	74,46	1,28	-12,32	75,27	1,28	8,25	19,32	1,50	18,68	12,27	1,89
Moduuli_223	25.4.17 5:11	-2,63	75,95	2,73	-4,62	77,16	2,39	8,15	19,77	1,53	18,57	12,24	1,87
Moduuli_223	25.4.17 6:11	-12,18	73,23	1,26	-10,74	72,09	1,39	9,28	20,70	1,73	18,60	13,05	1,99
Moduuli_223	25.4.17 7:11	-13,32	73,61	1,15	-12,18	72,95	1,25	9,03	19,37	1,59	18,63	12,79	1,96
Moduuli_223	25.4.17 8:11	-12,25	74,55	1,28	-11,76	74,30	1,32	8,64	19,41	1,55	18,61	12,65	1,94
Moduuli_223	25.4.17 9:11	-13,30	73,92	1,16	-12,54	74,49	1,24	8,42	19,63	1,55	18,64	12,59	1,93
Moduuli_223	25.4.17 10:11	-12,06	74,36	1,29	-11,93	75,01	1,32	8,30	19,69	1,54	18,67	12,54	1,92
Moduuli_223	25.4.17 11:11	-13,44	73,70	1,14	-12,92	74,90	1,21	8,24	19,86	1,55	18,80	12,58	1,95
Moduuli_223	25.4.17 12:11	-12,52	74,09	1,24	-12,48	75,19	1,26	8,24	19,83	1,54	18,92	12,55	1,96
Moduuli_223	25.4.17 13:11	-2,85	75,91	2,69	-4,85	77,34	2,36	8,28	20,26	1,58	19,00	12,58	1,97
Moduuli_223	25.4.17 14:11	-12,22	73,09	1,25	-10,78	72,41	1,39	9,53	21,29	1,81	19,27	13,39	2,13
Moduuli_223	25.4.17 15:11	-14,12	73,43	1,08	-12,82	73,48	1,20	9,36	19,89	1,67	19,43	13,11	2,11

Moduuli_223	25.4.17 16:11	-13,56	75,10	1,16	-12,77	75,48	1,24	8,98	19,93	1,63	19,52	12,94	2,09
Moduuli_223	25.4.17 17:11	-12,50	75,44	1,26	-12,26	76,14	1,30	8,77	20,09	1,62	19,50	12,83	2,07
Moduuli_223	25.4.17 18:11	-14,25	73,62	1,07	-13,30	75,26	1,18	8,62	19,98	1,60	19,35	12,68	2,03
Moduuli_223	25.4.17 19:11	-14,60	74,88	1,06	-13,78	76,09	1,15	8,48	19,87	1,57	19,27	12,59	2,01
Moduuli_223	25.4.17 20:11	-14,14	75,37	1,11	-13,64	76,18	1,16	8,35	19,70	1,54	19,17	12,46	1,97
Moduuli_223	25.4.17 21:11	-4,50	77,60	2,43	-6,42	78,23	2,11	8,25	19,86	1,55	19,06	12,39	1,95
Moduuli_223	25.4.17 22:11	-11,54	74,37	1,35	-10,46	73,03	1,44	9,27	20,76	1,73	19,05	12,99	2,04
Moduuli_223	25.4.17 23:11	-14,08	75,74	1,12	-12,98	74,47	1,20	9,05	19,37	1,59	19,00	12,71	1,99
Moduuli_223	26.4.17 0:11	-13,15	76,24	1,21	-12,62	75,40	1,25	8,63	19,34	1,55	18,90	12,54	1,95
Moduuli_223	26.4.17 1:11	-12,28	76,36	1,30	-12,26	75,87	1,30	8,34	19,44	1,52	18,78	12,37	1,91
Moduuli_223	26.4.17 2:11	-14,28	74,27	1,08	-13,44	74,94	1,16	8,16	19,51	1,51	18,68	12,34	1,90
Moduuli_223	26.4.17 3:11	-14,70	75,32	1,06	-13,97	75,78	1,13	8,01	19,40	1,49	18,59	12,25	1,87
Moduuli_223	26.4.17 4:11	-14,46	75,68	1,08	-13,91	75,95	1,14	7,86	19,36	1,47	18,52	12,16	1,85
Moduuli_223	26.4.17 5:11	-3,16	77,60	2,68	-5,25	78,07	2,31	7,84	19,83	1,50	18,49	12,15	1,84
Moduuli_223	26.4.17 6:11	-11,54	74,73	1,35	-10,32	72,79	1,45	9,08	20,90	1,72	18,58	12,97	1,98
Moduuli_223	26.4.17 7:11	-13,95	76,26	1,14	-12,82	74,53	1,22	8,86	19,41	1,58	18,62	12,72	1,95
Moduuli_223	26.4.17 8:11	-12,98	76,44	1,23	-12,48	75,44	1,27	8,44	19,41	1,53	18,63	12,59	1,93
Moduuli_223	26.4.17 9:11	-12,66	75,89	1,26	-12,36	75,63	1,28	8,21	19,72	1,53	18,70	12,55	1,93
Moduuli_223	26.4.17 10:11	-14,54	74,69	1,06	-13,62	75,44	1,15	8,12	19,89	1,53	18,80	12,51	1,94
Moduuli_223	26.4.17 11:11	-14,38	75,70	1,09	-13,70	76,32	1,16	8,12	19,95	1,54	18,98	12,54	1,96
Moduuli_223	26.4.17 12:11	-13,94	76,04	1,13	-13,60	76,70	1,18	8,11	19,95	1,54	19,09	12,50	1,97
Moduuli_223	26.4.17 13:11	-4,93	78,38	2,37	-6,84	79,15	2,07	8,16	20,16	1,56	19,20	12,50	1,98
Moduuli_223	26.4.17 14:11	-11,26	75,37	1,40	-10,34	74,57	1,49	9,32	21,32	1,78	19,44	13,21	2,13
Moduuli_223	26.4.17 15:11	-14,10	76,29	1,12	-13,02	75,80	1,22	9,27	19,93	1,66	19,52	12,94	2,09
Moduuli_223	26.4.17 16:11	-13,16	76,89	1,22	-12,66	76,89	1,27	8,94	19,86	1,62	19,52	12,80	2,07
Moduuli_223	26.4.17 17:11	-12,28	76,99	1,31	-12,30	77,36	1,32	8,71	19,91	1,60	19,45	12,65	2,04
Moduuli_223	26.4.17 18:11	-14,32	74,94	1,08	-13,48	76,44	1,18	8,58	19,90	1,58	19,37	12,56	2,01
Moduuli_223	26.4.17 19:11	-14,61	75,98	1,07	-13,92	77,22	1,15	8,43	19,79	1,56	19,28	12,46	1,99
Moduuli_223	26.4.17 20:11	-14,28	76,43	1,11	-13,84	77,47	1,16	8,34	19,63	1,54	19,19	12,37	1,96
Moduuli_223	26.4.17 21:11	-4,80	78,62	2,40	-6,70	79,52	2,10	8,24	19,86	1,55	19,13	12,28	1,94
Moduuli_223	26.4.17 22:11	-11,18	75,60	1,41	-10,26	74,60	1,50	9,32	20,91	1,75	19,14	13,02	2,06
Moduuli_223	26.4.17 23:11	-14,14	76,43	1,12	-13,04	75,52	1,21	9,14	19,43	1,61	19,10	12,67	2,00
Moduuli_223	27.4.17 0:11	-13,31	76,91	1,21	-12,76	76,44	1,25	8,71	19,33	1,55	19,02	12,51	1,96
Moduuli_223	27.4.17 1:11	-12,46	76,96	1,29	-12,40	76,88	1,30	8,42	19,47	1,53	18,93	12,42	1,94
Moduuli_223	27.4.17 2:11	-13,92	75,14	1,12	-13,24	75,93	1,20	8,22	19,53	1,52	18,84	12,33	1,91
Moduuli_223	27.4.17 3:11	-14,72	75,54	1,06	-13,95	76,41	1,14	8,10	19,50	1,50	18,76	12,23	1,89
Moduuli_223	27.4.17 4:11	-14,46	76,03	1,09	-13,94	76,69	1,14	7,97	19,39	1,48	18,69	12,21	1,88
Moduuli_223	27.4.17 5:11	-3,52	78,22	2,63	-5,62	78,96	2,27	7,93	19,76	1,51	18,64	12,13	1,86
Moduuli_223	27.4.17 6:11	-11,06	75,64	1,42	-10,02	73,98	1,51	9,16	20,98	1,74	18,69	13,01	2,00
Moduuli_223	27.4.17 7:11	-14,06	76,48	1,13	-12,92	75,08	1,22	8,97	19,38	1,58	18,74	12,73	1,96
Moduuli_223	27.4.17 8:11	-13,16	76,69	1,22	-12,60	75,96	1,26	8,52	19,43	1,54	18,75	12,56	1,94
Moduuli_223	27.4.17 9:11	-12,28	76,56	1,31	-12,20	76,41	1,31	8,28	19,68	1,54	18,80	12,51	1,94
Moduuli_223	27.4.17 10:11	-14,50	74,63	1,06	-13,54	75,69	1,17	8,20	19,91	1,55	18,94	12,49	1,95
Moduuli_223	27.4.17 11:11	-14,46	75,78	1,08	-13,76	76,67	1,16	8,21	19,98	1,55	19,14	12,55	1,98
Moduuli_223	27.4.17 12:11	-13,98	76,23	1,13	-13,62	77,14	1,18	8,24	20,05	1,56	19,40	12,57	2,02
Moduuli_223	27.4.17 13:11	-5,52	78,64	2,28	-7,34	79,62	2,01	8,32	20,24	1,58	19,58	12,56	2,04
Moduuli_223	27.4.17 14:11	-11,10	75,60	1,42	-10,20	75,10	1,51	9,54	21,49	1,83	19,83	13,30	2,19
Moduuli_223	27.4.17 15:11	-14,12	76,46	1,12	-13,02	76,20	1,22	9,52	20,00	1,70	19,93	13,00	2,16
Moduuli_223	27.4.17 16:11	-13,17	77,11	1,22	-12,68	77,36	1,28	9,24	19,98	1,66	20,08	12,88	2,16
Moduuli_223	27.4.17 17:11	-12,28	77,16	1,32	-12,27	77,92	1,33	9,08	20,06	1,65	20,10	12,79	2,15
Moduuli_223	27.4.17 18:11	-14,44	75,56	1,08	-13,61	77,27	1,18	8,98	20,09	1,64	20,11	12,72	2,14
Moduuli_223	27.4.17 19:11	-14,28	76,71	1,11	-13,72	78,16	1,19	8,94	20,02	1,63	20,19	12,62	2,13
Moduuli_223	27.4.17 20:11	-13,79	77,16	1,16	-13,58	78,38	1,20	8,92	19,85	1,62	20,19	12,48	2,11
Moduuli_223	27.4.17 21:11	-5,42	79,28	2,31	-7,26	80,39	2,04	8,83	19,82	1,61	20,06	12,37	2,07
Moduuli_223	27.4.17 22:11	-11,08	75,93	1,43	-10,16	75,31	1,52	9,88	20,92	1,82	19,95	13,01	2,16
Moduuli_223	27.4.17 23:11	-14,16	76,85	1,13	-13,06	76,17	1,22	9,66	19,28	1,65	19,79	12,62	2,08
Moduuli_223	28.4.17 0:11	-13,19	77,38	1,23	-12,70	76,93	1,27	9,16	19,12	1,58	19,54	12,41	2,01
Moduuli_223	28.4.17 1:11	-12,26	77,37	1,32	-12,30	77,21	1,32	8,80	19,20	1,55	19,32	12,28	1,96
Moduuli_223	28.4.17 2:11	-14,46	75,37	1,08	-13,60	76,20	1,17	8,52	19,18	1,52	19,11	12,14	1,92
Moduuli_223	28.4.17 3:11	-14,62	76,30	1,08	-13,96	76,84	1,14	8,31	19,11	1,49	18,92	12,08	1,88
Moduuli_223	28.4.17 4:11	-14,22	76,60	1,12	-13,86	76,92	1,15	8,10	18,98	1,46	18,76	11,97	1,85
Moduuli_223	28.4.17 5:11	-6,14	79,00	2,18	-7,88	79,05	1,91	7,92	19,05	1,45	18,64	11,93	1,83
Moduuli_223	28.4.17 6:11	-11,11	75,44	1,41	-10,24	74,22	1,49	8,95	20,53	1,68	18,69	12,61	1,94

Moduuli_223	28.4.17 7:11	-14,29	75,95	1,10	-13,15	74,75	1,19	8,81	19,11	1,55	18,75	12,43	1,92
Moduuli_223	28.4.17 8:11	-13,54	76,67	1,18	-12,93	75,86	1,23	8,43	18,95	1,49	18,58	12,18	1,86
Moduuli_223	28.4.17 9:11	-12,78	76,71	1,26	-12,63	76,10	1,26	8,06	19,00	1,46	18,38	12,15	1,83
Moduuli_223	28.4.17 10:11	-12,41	76,42	1,29	-12,46	76,25	1,28	7,93	19,31	1,47	18,58	12,18	1,86
Moduuli_223	28.4.17 11:11	-14,40	74,53	1,07	-13,66	75,45	1,15	7,94	19,57	1,49	18,82	12,25	1,90
Moduuli_223	28.4.17 12:11	-14,56	75,34	1,07	-13,98	76,15	1,13	7,98	19,62	1,50	18,98	12,24	1,92
Moduuli_223	28.4.17 13:11	-3,94	78,18	2,55	-6,01	78,94	2,20	8,09	20,07	1,55	19,23	12,31	1,96
Moduuli_223	28.4.17 14:11	-11,06	75,61	1,42	-9,96	74,28	1,52	9,55	21,62	1,84	19,65	13,24	2,16
Moduuli_223	28.4.17 15:11	-13,58	77,06	1,18	-12,68	75,88	1,25	9,54	19,91	1,69	19,98	13,08	2,18
Moduuli_223	28.4.17 16:11	-12,32	76,90	1,31	-12,09	76,77	1,33	9,25	20,05	1,67	20,13	12,93	2,17
Moduuli_223	28.4.17 17:11	-14,36	75,25	1,08	-13,40	76,56	1,19	9,14	20,21	1,67	20,27	12,84	2,18
Moduuli_223	28.4.17 18:11	-13,88	76,46	1,15	-13,28	77,65	1,22	9,09	20,13	1,66	20,27	12,77	2,17
Moduuli_223	28.4.17 19:11	-13,12	76,80	1,22	-13,02	78,01	1,25	9,05	19,99	1,64	20,28	12,64	2,15
Moduuli_223	28.4.17 20:11	-12,45	76,86	1,29	-12,78	78,11	1,28	8,99	19,84	1,62	20,24	12,56	2,13
Moduuli_223	28.4.17 21:11	-4,74	78,79	2,42	-6,70	80,17	2,12	8,90	19,87	1,62	20,11	12,39	2,08
Moduuli_223	28.4.17 22:11	-10,92	75,68	1,44	-9,92	75,03	1,55	10,07	21,17	1,86	20,06	13,17	2,20
Moduuli_223	28.4.17 23:11	-13,96	76,64	1,14	-12,86	76,03	1,24	9,85	19,40	1,68	19,94	12,80	2,13
Moduuli_223	29.4.17 0:11	-12,84	76,99	1,26	-12,41	76,87	1,30	9,32	19,27	1,61	19,72	12,53	2,05
Moduuli_223	29.4.17 1:11	-13,18	75,78	1,20	-12,62	76,48	1,27	8,96	19,31	1,58	19,52	12,41	2,01
Moduuli_223	29.4.17 2:11	-14,52	75,56	1,07	-13,69	76,72	1,17	8,68	19,32	1,55	19,32	12,28	1,96
Moduuli_223	29.4.17 3:11	-14,12	76,23	1,12	-13,62	77,14	1,18	8,47	19,22	1,52	19,14	12,19	1,93
Moduuli_223	29.4.17 4:11	-13,58	76,35	1,17	-13,44	77,10	1,20	8,27	19,10	1,49	18,99	12,11	1,90
Moduuli_223	29.4.17 5:11	-5,97	78,55	2,20	-7,72	79,25	1,94	8,08	19,17	1,48	18,83	11,99	1,86
Moduuli_223	29.4.17 6:11	-11,10	74,92	1,40	-10,09	74,22	1,51	9,12	20,72	1,71	18,80	12,71	1,97
Moduuli_223	29.4.17 7:11	-14,28	75,53	1,10	-13,10	74,74	1,19	8,96	19,12	1,56	18,79	12,51	1,93
Moduuli_223	29.4.17 8:11	-13,54	76,12	1,17	-12,88	75,80	1,23	8,53	19,11	1,52	18,79	12,38	1,91
Moduuli_223	29.4.17 9:11	-12,64	76,17	1,26	-12,50	76,24	1,28	8,29	19,30	1,51	18,84	12,33	1,91
Moduuli_223	29.4.17 10:11	-13,30	74,91	1,18	-12,86	75,83	1,23	8,16	19,45	1,51	18,88	12,30	1,91
Moduuli_223	29.4.17 11:11	-14,59	74,60	1,05	-13,84	75,97	1,14	8,10	19,56	1,51	18,94	12,29	1,92
Moduuli_223	29.4.17 12:11	-14,40	75,32	1,08	-13,88	76,49	1,15	8,08	19,55	1,51	19,02	12,25	1,92
Moduuli_223	29.4.17 13:11	-7,00	78,10	2,02	-8,56	78,84	1,81	8,05	19,54	1,50	19,02	12,18	1,91
Moduuli_223	29.4.17 14:11	-11,20	74,48	1,39	-10,20	74,13	1,49	9,12	21,04	1,74	19,10	12,87	2,03
Moduuli_223	29.4.17 15:11	-14,28	75,00	1,09	-13,10	74,74	1,19	9,08	19,48	1,60	19,18	12,70	2,01
Moduuli_223	29.4.17 16:11	-13,63	75,99	1,16	-12,97	76,04	1,23	8,73	19,40	1,56	19,18	12,53	1,99
Moduuli_223	29.4.17 17:11	-12,83	76,11	1,24	-12,61	76,56	1,27	8,50	19,49	1,54	19,12	12,41	1,96
Moduuli_223	29.4.17 18:11	-12,40	75,92	1,28	-12,44	76,76	1,29	8,35	19,57	1,53	19,09	12,37	1,95
Moduuli_223	29.4.17 19:11	-14,44	73,99	1,06	-13,68	75,82	1,15	8,23	19,50	1,52	19,02	12,32	1,93
Moduuli_223	29.4.17 20:11	-14,67	74,75	1,05	-14,04	76,31	1,13	8,11	19,43	1,50	18,95	12,23	1,91
Moduuli_223	29.4.17 21:11	-4,68	77,77	2,40	-6,68	78,98	2,09	8,05	19,61	1,51	18,90	12,14	1,89
Moduuli_223	29.4.17 22:11	-10,88	74,78	1,43	-9,74	73,79	1,54	9,31	21,22	1,78	18,93	13,02	2,03
Moduuli_223	29.4.17 23:11	-14,12	75,53	1,11	-12,89	74,66	1,21	9,18	19,32	1,60	18,92	12,68	1,98
Moduuli_223	30.4.17 0:11	-13,20	75,87	1,20	-12,56	75,64	1,26	8,70	19,23	1,54	18,84	12,53	1,94
Moduuli_223	30.4.17 1:11	-12,28	75,66	1,29	-12,16	76,02	1,31	8,38	19,39	1,52	18,75	12,36	1,91
Moduuli_223	30.4.17 2:11	-14,52	73,66	1,05	-13,56	75,18	1,16	8,18	19,46	1,51	18,68	12,34	1,90
Moduuli_223	30.4.17 3:11	-14,46	74,82	1,07	-13,76	76,05	1,15	8,05	19,41	1,49	18,64	12,26	1,88
Moduuli_223	30.4.17 4:11	-14,10	75,13	1,11	-13,68	76,30	1,16	7,94	19,35	1,48	18,62	12,22	1,87
Moduuli_223	30.4.17 5:11	-7,00	77,75	2,01	-8,58	78,61	1,80	7,84	19,38	1,47	18,58	12,18	1,86
Moduuli_223	30.4.17 6:11	-11,28	74,17	1,37	-10,18	73,86	1,49	8,89	21,03	1,71	18,66	12,87	1,97
Moduuli_223	30.4.17 7:11	-14,34	74,60	1,08	-13,08	74,39	1,19	8,84	19,41	1,57	18,69	12,68	1,95
Moduuli_223	30.4.17 8:11	-13,74	75,65	1,15	-12,98	75,74	1,22	8,46	19,35	1,53	18,67	12,47	1,91
Moduuli_223	30.4.17 9:11	-12,92	75,81	1,23	-12,64	76,25	1,26	8,22	19,47	1,51	18,67	12,40	1,90
Moduuli_223	30.4.17 10:11	-12,32	75,75	1,29	-12,38	76,56	1,30	8,07	19,58	1,51	18,72	12,42	1,91
Moduuli_223	30.4.17 11:11	-14,32	73,72	1,07	-13,59	75,60	1,16	8,01	19,66	1,51	18,80	12,38	1,92
Moduuli_223	30.4.17 12:11	-14,64	74,61	1,05	-13,98	76,28	1,13	8,00	19,66	1,50	18,88	12,34	1,92
Moduuli_223	30.4.17 13:11	-5,88	77,72	2,19	-7,63	78,83	1,94	8,02	19,86	1,52	18,96	12,30	1,92
Moduuli_223	30.4.17 14:11	-11,20	74,55	1,39	-10,02	73,96	1,51	9,26	21,53	1,79	19,17	13,16	2,08
Moduuli_223	30.4.17 15:11	-14,16	75,27	1,10	-12,92	74,85	1,21	9,25	19,73	1,64	19,30	12,93	2,07
Moduuli_223	30.4.17 16:11	-13,26	76,10	1,20	-12,62	76,18	1,26	8,92	19,72	1,61	19,40	12,77	2,05
Moduuli_223	30.4.17 17:11	-12,28	76,16	1,30	-12,18	76,75	1,32	8,70	19,88	1,60	19,43	12,71	2,05
Moduuli_223	30.4.17 18:11	-14,44	74,52	1,07	-13,56	76,16	1,17	8,60	19,88	1,58	19,43	12,58	2,02
Moduuli_223	30.4.17 19:11	-14,30	75,73	1,10	-13,66	76,98	1,17	8,49	19,75	1,56	19,36	12,49	2,00
Moduuli_223	30.4.17 20:11	-13,67	76,07	1,16	-13,45	77,17	1,20	8,38	19,55	1,54	19,24	12,38	1,97
Moduuli_223	30.4.17 21:11	-6,90	78,54	2,05	-8,50	79,33	1,83	8,24	19,47	1,52	19,14	12,29	1,94

Moduuli_223	30.4.17 22:11	-11,13	74,70	1,40	-10,01	74,16	1,52	9,29	21,19	1,77	19,10	12,94	2,04
Moduuli_223	30.4.17 23:11	-14,24	75,54	1,10	-13,02	74,92	1,20	9,18	19,32	1,60	19,03	12,65	1,99
Moduuli 599	14.4.17 0:50	19,26	56,79	9,04	9,18	21,35	1,77	10,15	18,41	1,63	19,06	49,28	7,75
Moduuli 599	14.4.17 1:50	19,08	56,81	8,95	9,01	21,28	1,74	9,98	18,35	1,61	18,88	49,25	7,66
Moduuli 599	14.4.17 2:50	18,92	56,81	8,86	8,86	21,41	1,74	9,84	18,54	1,61	18,74	49,22	7,59
Moduuli 599	14.4.17 3:50	18,77	56,87	8,79	8,71	21,41	1,72	9,71	18,48	1,59	18,58	49,19	7,51
Moduuli 599	14.4.17 4:49	18,64	56,99	8,73	8,66	21,64	1,73	9,65	19,17	1,64	18,47	49,22	7,46
Moduuli 599	14.4.17 5:49	18,60	57,01	8,72	9,94	28,35	2,47	10,75	24,58	2,26	18,45	49,19	7,45
Moduuli 599	14.4.17 6:49	18,57	57,10	8,71	9,26	23,42	1,95	10,16	19,92	1,76	18,41	49,22	7,44
Moduuli 599	14.4.17 7:49	18,54	57,19	8,71	8,80	22,03	1,78	9,74	18,81	1,62	18,36	49,22	7,41
Moduuli 599	14.4.17 8:50	18,53	57,24	8,71	8,59	21,74	1,73	9,54	18,74	1,59	18,34	49,22	7,40
Moduuli 599	14.4.17 9:50	18,53	57,30	8,72	8,48	21,61	1,71	9,43	18,61	1,57	18,32	49,25	7,40
Moduuli 599	14.4.17 10:50	18,57	57,36	8,75	8,43	21,54	1,70	9,40	18,68	1,57	18,38	49,22	7,42
Moduuli 599	14.4.17 11:50	18,70	57,39	8,83	8,42	21,48	1,69	9,38	18,61	1,56	18,49	49,22	7,47
Moduuli 599	14.4.17 12:50	18,88	57,45	8,94	8,52	21,35	1,69	9,48	18,94	1,60	18,66	49,28	7,56
Moduuli 599	14.4.17 13:49	19,10	57,42	9,05	9,89	27,65	2,40	10,70	24,06	2,21	18,90	49,28	7,68
Moduuli 599	14.4.17 14:49	19,40	57,39	9,22	9,48	22,84	1,93	10,34	19,53	1,75	19,20	49,28	7,82
Moduuli 599	14.4.17 15:49	19,58	57,30	9,31	9,24	21,35	1,78	10,16	18,41	1,63	19,36	49,28	7,90
Moduuli 599	14.4.17 16:49	19,67	57,25	9,35	9,20	20,89	1,73	10,14	18,22	1,61	19,46	49,25	7,94
Moduuli 599	14.4.17 17:50	19,63	57,19	9,32	9,17	20,57	1,70	10,14	18,02	1,59	19,42	49,20	7,91
Moduuli 599	14.4.17 18:50	19,56	57,10	9,27	9,15	20,50	1,70	10,14	18,05	1,60	19,36	49,17	7,88
Moduuli 599	14.4.17 19:50	19,45	57,04	9,19	9,10	20,34	1,68	10,09	17,92	1,58	19,27	49,11	7,83
Moduuli 599	14.4.17 20:50	19,32	57,07	9,12	9,09	20,44	1,68	10,09	18,38	1,62	19,15	49,11	7,77
Moduuli 599	14.4.17 21:50	19,24	57,07	9,08	10,33	27,08	2,43	11,20	23,71	2,25	19,06	49,05	7,72
Moduuli 599	14.4.17 22:49	19,14	57,10	9,03	9,70	22,26	1,91	10,60	19,13	1,74	18,97	49,08	7,68
Moduuli 599	14.4.17 23:50	19,00	57,16	8,96	9,20	20,83	1,73	10,16	18,09	1,60	18,83	49,08	7,61
Moduuli 599	15.4.17 0:50	18,84	57,22	8,88	8,92	20,57	1,68	9,91	18,02	1,57	18,67	49,05	7,53
Moduuli 599	15.4.17 1:50	18,73	57,24	8,82	8,73	20,50	1,65	9,72	17,95	1,54	18,55	49,05	7,47
Moduuli 599	15.4.17 2:50	18,62	57,33	8,77	8,60	20,57	1,64	9,60	18,12	1,55	18,47	48,99	7,43
Moduuli 599	15.4.17 3:50	18,55	57,36	8,74	8,50	20,57	1,63	9,48	18,02	1,52	18,39	48,99	7,39
Moduuli 599	15.4.17 4:50	18,47	57,47	8,71	8,46	20,66	1,63	9,46	18,48	1,56	18,30	48,99	7,35
Moduuli 599	15.4.17 5:50	18,48	57,47	8,72	9,77	27,65	2,39	10,58	24,19	2,20	18,32	48,99	7,36
Moduuli 599	15.4.17 6:50	18,44	57,53	8,71	9,14	22,71	1,88	10,05	19,46	1,71	18,30	48,99	7,35
Moduuli 599	15.4.17 7:49	18,42	57,65	8,71	8,68	21,28	1,71	9,64	18,38	1,57	18,27	49,05	7,34
Moduuli 599	15.4.17 8:50	18,40	57,70	8,71	8,47	20,96	1,66	9,45	18,22	1,54	18,26	49,05	7,34
Moduuli 599	15.4.17 9:49	18,43	57,76	8,74	8,38	20,89	1,64	9,35	18,15	1,52	18,26	49,05	7,34
Moduuli 599	15.4.17 10:49	18,54	57,82	8,80	8,35	20,89	1,64	9,32	18,22	1,52	18,35	49,05	7,38
Moduuli 599	15.4.17 11:50	18,69	57,82	8,89	8,38	20,96	1,65	9,36	18,22	1,53	18,51	49,05	7,46
Moduuli 599	15.4.17 12:50	18,85	57,85	8,98	8,49	20,83	1,65	9,46	18,41	1,56	18,67	49,08	7,53
Moduuli 599	15.4.17 13:50	19,11	57,85	9,13	9,85	27,27	2,37	10,68	23,77	2,18	18,93	49,08	7,66
Moduuli 599	15.4.17 14:50	19,30	57,79	9,23	9,46	22,58	1,91	10,33	19,26	1,73	19,12	49,08	7,75
Moduuli 599	15.4.17 15:50	19,54	57,73	9,36	9,21	21,12	1,75	10,13	18,15	1,60	19,34	49,11	7,86
Moduuli 599	15.4.17 16:50	19,61	57,65	9,38	9,17	20,76	1,72	10,11	17,99	1,59	19,41	49,08	7,89
Moduuli 599	15.4.17 17:49	19,75	57,59	9,46	9,19	20,57	1,71	10,13	17,82	1,58	19,54	49,05	7,95
Moduuli 599	15.4.17 18:50	19,82	57,50	9,48	9,24	20,57	1,71	10,19	17,89	1,59	19,60	49,05	7,98
Moduuli 599	15.4.17 19:50	19,74	57,39	9,42	9,26	20,54	1,71	10,22	17,76	1,58	19,56	48,96	7,95
Moduuli 599	15.4.17 20:50	19,62	57,39	9,35	9,26	20,50	1,71	10,25	18,09	1,61	19,44	48,96	7,89
Moduuli 599	15.4.17 21:50	19,52	57,39	9,29	10,52	27,27	2,47	11,39	23,68	2,28	19,35	48,93	7,84
Moduuli 599	15.4.17 22:50	19,39	57,39	9,22	9,89	22,39	1,95	10,82	19,00	1,76	19,22	48,90	7,77
Moduuli 599	15.4.17 23:50	19,24	57,42	9,13	9,38	21,02	1,77	10,36	18,02	1,62	19,08	48,93	7,71
Moduuli 599	16.4.17 0:50	19,08	57,47	9,05	9,11	20,83	1,72	10,09	17,96	1,58	18,90	48,90	7,62
Moduuli 599	16.4.17 1:50	18,92	57,47	8,96	8,91	20,76	1,69	9,90	17,89	1,56	18,75	48,84	7,54
Moduuli 599	16.4.17 2:50	18,77	57,56	8,89	8,76	20,89	1,68	9,75	18,09	1,56	18,60	48,84	7,47
Moduuli 599	16.4.17 3:50	18,65	57,62	8,83	8,64	20,89	1,67	9,62	18,02	1,54	18,50	48,81	7,41
Moduuli 599	16.4.17 4:50	18,58	57,73	8,81	8,54	20,96	1,66	9,56	18,41	1,57	18,40	48,87	7,38
Moduuli 599	16.4.17 5:50	18,55	57,76	8,80	9,85	28,13	2,44	10,68	24,45	2,24	18,40	48,81	7,37
Moduuli 599	16.4.17 6:50	18,54	57,82	8,80	9,26	23,06	1,92	10,12	19,59	1,73	18,38	48,84	7,36
Moduuli 599	16.4.17 7:50	18,50	57,96	8,80	8,77	21,61	1,74	9,70	18,41	1,58	18,34	48,90	7,35
Moduuli 599	16.4.17 8:50	18,47	58,02	8,80	8,54	21,28	1,69	9,50	18,28	1,55	18,30	48,93	7,34
Moduuli 599	16.4.17 9:50	18,46	58,08	8,80	8,44	21,28	1,68	9,40	18,28	1,54	18,31	48,90	7,34
Moduuli 599	16.4.17 10:50	18,53	58,13	8,85	8,40	21,35	1,68	9,36	18,35	1,54	18,36	48,90	7,36
Moduuli 599	16.4.17 11:50	18,64	58,13	8,91	8,40	21,41	1,68	9,37	18,38	1,54	18,47	48,90	7,41
Moduuli 599	16.4.17 12:50	18,75	58,25	8,99	8,46	21,22	1,68	9,44	18,54	1,56	18,58	48,93	7,47

Moduuli 599	16.4.17 13:50	18,88	58,25	9,06	9,80	28,03	2,42	10,64	24,26	2,22	18,70	48,96	7,53
Moduuli 599	16.4.17 14:50	19,09	58,28	9,18	9,37	23,10	1,94	10,26	19,53	1,74	18,90	48,99	7,63
Moduuli 599	16.4.17 15:50	19,28	58,22	9,29	9,08	21,61	1,78	10,00	18,41	1,61	19,08	49,05	7,73
Moduuli 599	16.4.17 16:50	19,38	58,16	9,33	9,04	21,22	1,74	9,96	18,22	1,59	19,19	48,99	7,77
Moduuli 599	16.4.17 17:50	19,42	58,08	9,34	9,03	21,09	1,73	9,96	18,09	1,58	19,22	48,99	7,78
Moduuli 599	16.4.17 18:50	19,40	58,08	9,33	9,01	21,09	1,73	9,99	18,15	1,59	19,20	48,93	7,76
Moduuli 599	16.4.17 19:50	19,31	57,99	9,27	8,99	21,06	1,72	9,97	18,09	1,58	19,14	48,93	7,74
Moduuli 599	16.4.17 20:50	19,24	58,02	9,23	8,98	20,96	1,71	9,96	18,32	1,60	19,04	48,93	7,69
Moduuli 599	16.4.17 21:50	19,15	58,08	9,19	10,24	28,00	2,49	11,10	24,26	2,29	18,98	48,93	7,66
Moduuli 599	16.4.17 22:50	19,06	58,08	9,14	9,63	22,97	1,96	10,57	19,40	1,77	18,89	48,93	7,62
Moduuli 599	16.4.17 23:50	18,90	58,13	9,05	9,16	21,54	1,78	10,11	18,35	1,62	18,75	48,96	7,55
Moduuli 599	17.4.17 0:50	18,76	58,19	8,98	8,88	21,35	1,73	9,85	18,25	1,58	18,59	48,96	7,48
Moduuli 599	17.4.17 1:50	18,64	58,25	8,93	8,68	21,32	1,71	9,66	18,22	1,56	18,48	48,93	7,42
Moduuli 599	17.4.17 2:50	18,54	58,28	8,87	8,56	21,48	1,71	9,54	18,41	1,56	18,38	48,93	7,38
Moduuli 599	17.4.17 3:50	18,46	58,33	8,84	8,46	21,54	1,70	9,44	18,38	1,55	18,30	48,93	7,34
Moduuli 599	17.4.17 4:50	18,38	58,42	8,81	8,38	21,41	1,68	9,38	18,68	1,57	18,22	48,96	7,31
Moduuli 599	17.4.17 5:50	18,37	58,50	8,82	9,68	28,86	2,47	10,52	24,96	2,26	18,21	48,93	7,30
Moduuli 599	17.4.17 6:50	18,35	58,56	8,81	9,10	23,64	1,95	10,00	19,92	1,75	18,22	48,99	7,31
Moduuli 599	17.4.17 7:50	18,36	58,65	8,83	8,64	22,13	1,77	9,60	18,74	1,60	18,20	49,02	7,31
Moduuli 599	17.4.17 8:50	18,38	58,70	8,85	8,44	21,74	1,71	9,40	18,54	1,56	18,20	49,02	7,31
Moduuli 599	17.4.17 9:50	18,40	58,76	8,87	8,36	21,61	1,70	9,30	18,48	1,54	18,24	49,05	7,33
Moduuli 599	17.4.17 10:50	18,47	58,76	8,91	8,34	21,48	1,68	9,29	18,48	1,54	18,30	49,05	7,36
Moduuli 599	17.4.17 11:50	18,59	58,76	8,98	8,37	21,48	1,69	9,32	18,48	1,55	18,40	49,08	7,41
Moduuli 599	17.4.17 12:50	18,71	58,82	9,05	8,42	21,15	1,67	9,38	18,51	1,56	18,54	49,11	7,48
Moduuli 599	17.4.17 13:50	18,92	58,82	9,17	9,78	28,16	2,43	10,61	24,48	2,23	18,74	49,14	7,58
Moduuli 599	17.4.17 14:50	19,13	58,76	9,28	9,38	23,06	1,94	10,27	19,56	1,74	18,97	49,14	7,69
Moduuli 599	17.4.17 15:50	19,24	58,76	9,35	9,09	21,41	1,76	10,01	18,35	1,61	19,06	49,17	7,73
Moduuli 599	17.4.17 16:50	19,36	58,68	9,40	9,04	20,96	1,72	9,96	18,18	1,59	19,18	49,17	7,79
Moduuli 599	17.4.17 17:50	19,38	58,56	9,40	9,02	20,63	1,69	9,95	17,89	1,56	19,19	49,11	7,79
Moduuli 599	17.4.17 18:50	19,36	58,53	9,38	9,01	20,54	1,68	9,96	17,96	1,57	19,16	49,11	7,77
Moduuli 599	17.4.17 19:50	19,28	58,45	9,32	8,96	20,34	1,66	9,93	17,82	1,55	19,10	49,11	7,74
Moduuli 599	17.4.17 20:50	19,16	58,48	9,26	8,93	20,24	1,65	9,92	18,02	1,57	19,00	49,08	7,69
Moduuli 599	17.4.17 21:50	19,09	58,48	9,22	10,22	27,65	2,46	11,10	24,23	2,28	18,93	49,05	7,65
Moduuli 599	17.4.17 22:50	19,00	58,51	9,17	9,62	22,51	1,92	10,57	19,20	1,75	18,86	49,05	7,62
Moduuli 599	17.4.17 23:50	18,87	58,56	9,10	9,12	20,89	1,73	10,08	18,02	1,59	18,71	49,08	7,55
Moduuli 599	18.4.17 0:50	18,72	58,62	9,03	8,86	20,57	1,67	9,82	17,89	1,55	18,56	49,05	7,48
Moduuli 599	18.4.17 1:50	18,59	58,65	8,96	8,66	20,44	1,64	9,64	17,82	1,52	18,42	49,05	7,41
Moduuli 599	18.4.17 2:50	18,50	58,70	8,92	8,54	20,50	1,63	9,51	17,95	1,52	18,34	49,05	7,38
Moduuli 599	18.4.17 3:50	18,40	58,73	8,87	8,42	20,57	1,62	9,41	17,95	1,51	18,26	49,02	7,33
Moduuli 599	18.4.17 4:50	18,34	58,82	8,85	8,34	20,37	1,60	9,32	18,02	1,51	18,17	49,05	7,30
Moduuli 599	18.4.17 5:50	18,30	58,90	8,84	9,62	27,97	2,39	10,47	24,51	2,22	18,16	49,05	7,29
Moduuli 599	18.4.17 6:50	18,29	58,99	8,84	9,06	22,97	1,89	9,98	19,53	1,71	18,16	49,05	7,29
Moduuli 599	18.4.17 7:50	18,29	59,05	8,85	8,61	21,35	1,70	9,57	18,35	1,56	18,14	49,11	7,29
Moduuli 599	18.4.17 8:50	18,29	59,13	8,87	8,34	20,70	1,62	9,30	17,82	1,49	18,12	49,13	7,29
Moduuli 599	18.4.17 9:50	18,30	59,13	8,87	8,28	20,70	1,61	9,24	18,05	1,50	18,13	49,13	7,29
Moduuli 599	18.4.17 10:50	18,54	59,16	9,01	8,30	20,63	1,61	9,23	17,95	1,49	18,36	49,16	7,40
Moduuli 599	18.4.17 11:50	18,88	59,16	9,20	8,42	20,60	1,62	9,33	18,05	1,51	18,66	49,19	7,55
Moduuli 599	18.4.17 12:50	19,24	59,11	9,40	8,62	20,27	1,62	9,52	17,95	1,52	19,00	49,22	7,71
Moduuli 599	18.4.17 13:50	19,70	58,99	9,66	10,05	26,69	2,35	10,83	23,48	2,17	19,45	49,23	7,93
Moduuli 599	18.4.17 14:50	19,80	58,68	9,67	9,83	21,96	1,90	10,66	18,81	1,72	19,58	49,05	7,97
Moduuli 599	18.4.17 15:50	20,07	58,76	9,84	9,58	20,41	1,74	10,47	17,66	1,60	19,82	49,26	8,12
Moduuli 599	18.4.17 16:50	20,35	58,51	9,97	9,62	19,85	1,70	10,48	17,36	1,57	20,11	49,17	8,26
Moduuli 599	18.4.17 17:50	20,39	58,31	9,96	9,68	19,59	1,68	10,56	17,17	1,56	20,15	49,11	8,27
Moduuli 599	18.4.17 18:50	20,33	58,16	9,90	9,70	19,43	1,67	10,60	17,17	1,57	20,11	49,05	8,24
Moduuli 599	18.4.17 19:50	20,26	58,05	9,84	9,68	19,33	1,66	10,63	17,10	1,56	20,07	48,99	8,21
Moduuli 599	18.4.17 20:50	20,09	57,99	9,73	9,64	19,20	1,64	10,60	17,17	1,57	19,89	48,96	8,11
Moduuli 599	18.4.17 21:50	19,95	58,02	9,65	10,90	26,44	2,46	11,76	23,36	2,30	19,77	48,93	8,04
Moduuli 599	18.4.17 22:50	19,79	58,02	9,55	10,26	21,51	1,92	11,21	18,45	1,75	19,60	48,90	7,96
Moduuli 599	18.4.17 23:50	19,58	58,05	9,43	9,71	19,98	1,72	10,69	17,30	1,59	19,39	48,90	7,85
Moduuli 599	19.4.17 0:50	19,34	58,11	9,30	9,38	19,59	1,65	10,38	17,20	1,55	19,17	48,87	7,74
Moduuli 599	19.4.17 1:50	19,14	58,13	9,19	9,14	19,49	1,61	10,12	17,13	1,51	18,98	48,81	7,64
Moduuli 599	19.4.17 2:50	18,95	58,19	9,09	8,96	19,59	1,60	9,95	17,30	1,51	18,78	48,81	7,55
Moduuli 599	19.4.17 3:50	18,78	58,28	9,01	8,78	19,59	1,58	9,78	17,30	1,49	18,60	48,78	7,46

Moduuli 599	19.4.17 4:50	18,65	58,39	8,95	8,66	19,59	1,57	9,64	17,43	1,49	18,48	48,78	7,40
Moduuli 599	19.4.17 5:50	18,60	58,48	8,94	9,91	27,33	2,38	10,78	24,13	2,23	18,44	48,75	7,38
Moduuli 599	19.4.17 6:50	18,55	58,59	8,93	9,32	22,32	1,87	10,24	19,07	1,70	18,42	48,81	7,38
Moduuli 599	19.4.17 7:50	18,53	58,70	8,93	8,84	20,63	1,67	9,78	17,82	1,54	18,36	48,81	7,35
Moduuli 599	19.4.17 8:50	18,55	58,76	8,95	8,62	20,18	1,61	9,56	17,56	1,49	18,39	48,84	7,37
Moduuli 599	19.4.17 9:50	18,61	58,82	9,00	8,52	20,05	1,59	9,48	17,56	1,49	18,44	48,84	7,39
Moduuli 599	19.4.17 10:50	18,76	58,82	9,08	8,50	19,98	1,58	9,46	17,50	1,48	18,57	48,84	7,45
Moduuli 599	19.4.17 11:50	18,92	58,82	9,17	8,58	19,98	1,59	9,52	17,50	1,48	18,73	48,84	7,53
Moduuli 599	19.4.17 12:50	19,15	58,88	9,31	8,66	19,72	1,58	9,58	17,43	1,48	18,94	48,93	7,64
Moduuli 599	19.4.17 13:50	19,50	58,82	9,51	10,14	27,01	2,39	10,94	23,81	2,22	19,30	48,87	7,80
Moduuli 599	19.4.17 14:50	19,76	58,76	9,66	9,84	21,96	1,90	10,68	18,77	1,72	19,56	48,93	7,94
Moduuli 599	19.4.17 15:50	19,61	58,76	9,57	9,47	20,18	1,71	10,38	17,43	1,57	19,40	48,93	7,86
Moduuli 599	19.4.17 16:50	19,86	58,71	9,71	9,38	19,66	1,65	10,29	17,20	1,54	19,64	48,99	7,99
Moduuli 599	19.4.17 17:50	19,97	58,51	9,74	9,40	19,39	1,63	10,32	17,04	1,52	19,75	48,90	8,03
Moduuli 599	19.4.17 18:50	20,02	58,39	9,75	9,44	19,33	1,63	10,36	17,04	1,53	19,80	48,87	8,05
Moduuli 599	19.4.17 19:50	20,01	58,28	9,72	9,43	19,13	1,61	10,38	16,84	1,51	19,81	48,81	8,04
Moduuli 599	19.4.17 20:50	19,89	58,22	9,64	9,44	19,04	1,61	10,43	17,04	1,54	19,70	48,75	7,98
Moduuli 599	19.4.17 21:50	19,80	58,25	9,59	10,78	26,69	2,46	11,64	23,61	2,31	19,63	48,75	7,95
Moduuli 599	19.4.17 22:50	19,69	58,28	9,53	10,20	21,48	1,91	11,14	18,41	1,74	19,53	48,75	7,90
Moduuli 599	19.4.17 23:50	19,51	58,33	9,44	9,65	19,79	1,69	10,63	17,17	1,57	19,34	48,78	7,81
Moduuli 599	20.4.17 0:50	19,32	58,36	9,33	9,34	19,39	1,63	10,34	16,97	1,52	19,16	48,75	7,72
Moduuli 599	20.4.17 1:50	19,14	58,39	9,23	9,10	19,26	1,59	10,10	16,90	1,49	18,97	48,72	7,62
Moduuli 599	20.4.17 2:50	18,99	58,42	9,15	8,94	19,33	1,58	9,95	17,04	1,49	18,83	48,69	7,55
Moduuli 599	20.4.17 3:50	18,84	58,48	9,07	8,80	19,33	1,56	9,79	16,97	1,47	18,68	48,69	7,48
Moduuli 599	20.4.17 4:50	18,68	58,56	9,00	8,67	19,26	1,54	9,67	17,10	1,47	18,54	48,69	7,41
Moduuli 599	20.4.17 5:50	18,62	58,68	8,98	9,95	27,24	2,38	10,82	24,06	2,23	18,48	48,69	7,39
Moduuli 599	20.4.17 6:50	18,61	58,82	9,00	9,38	22,09	1,86	10,31	18,87	1,69	18,46	48,72	7,38
Moduuli 599	20.4.17 7:50	18,60	58,90	9,00	8,88	20,37	1,66	9,86	17,59	1,53	18,44	48,75	7,38
Moduuli 599	20.4.17 8:50	18,63	58,96	9,03	8,66	19,92	1,59	9,62	17,33	1,48	18,48	48,78	7,40
Moduuli 599	20.4.17 9:50	18,70	58,99	9,07	8,58	19,79	1,58	9,54	17,27	1,47	18,56	48,81	7,44
Moduuli 599	20.4.17 10:50	18,84	59,02	9,16	8,56	19,79	1,57	9,53	17,30	1,47	18,64	48,81	7,48
Moduuli 599	20.4.17 11:50	19,06	58,96	9,28	8,62	19,79	1,58	9,58	17,27	1,47	18,85	48,81	7,58
Moduuli 599	20.4.17 12:50	19,28	58,93	9,40	8,74	19,59	1,58	9,66	17,23	1,48	19,05	48,81	7,67
Moduuli 599	20.4.17 13:50	19,26	58,96	9,39	10,14	27,17	2,40	10,98	23,87	2,23	19,06	48,81	7,68
Moduuli 599	20.4.17 14:50	19,49	58,99	9,53	9,75	22,03	1,90	10,64	18,74	1,71	19,30	48,87	7,80
Moduuli 599	20.4.17 15:50	19,58	58,91	9,57	9,41	20,31	1,71	10,33	17,43	1,56	19,37	48,84	7,83
Moduuli 599	20.4.17 16:50	19,53	58,85	9,53	9,25	19,79	1,65	10,20	17,13	1,52	19,33	48,81	7,81
Moduuli 599	20.4.17 17:50	19,46	58,82	9,49	9,17	19,59	1,62	10,13	17,04	1,51	19,26	48,81	7,77
Moduuli 599	20.4.17 18:50	19,40	58,76	9,44	9,10	19,62	1,62	10,08	17,10	1,51	19,20	48,81	7,75
Moduuli 599	20.4.17 19:50	19,30	58,76	9,38	9,03	19,59	1,61	10,01	17,04	1,49	19,14	48,81	7,72
Moduuli 599	20.4.17 20:50	19,23	58,76	9,34	8,96	19,46	1,59	9,96	17,10	1,49	19,03	48,78	7,66
Moduuli 599	20.4.17 21:50	19,14	58,79	9,29	10,26	27,39	2,44	11,14	24,13	2,28	18,97	48,78	7,63
Moduuli 599	20.4.17 22:50	19,07	58,88	9,27	9,73	22,13	1,90	10,66	18,74	1,72	18,90	48,78	7,60
Moduuli 599	20.4.17 23:50	18,94	58,93	9,20	9,20	20,44	1,70	10,15	17,50	1,55	18,78	48,81	7,55
Moduuli 599	21.4.17 0:50	18,82	58,99	9,14	8,90	20,05	1,63	9,88	17,33	1,51	18,65	48,81	7,48
Moduuli 599	21.4.17 1:50	18,72	59,05	9,09	8,74	19,92	1,60	9,71	17,27	1,48	18,54	48,81	7,43
Moduuli 599	21.4.17 2:50	18,65	59,10	9,06	8,62	20,05	1,60	9,60	17,40	1,48	18,47	48,81	7,40
Moduuli 599	21.4.17 3:50	18,59	59,13	9,03	8,53	20,05	1,59	9,50	17,36	1,47	18,43	48,81	7,38
Moduuli 599	21.4.17 4:50	18,56	59,19	9,03	8,46	19,98	1,58	9,45	17,50	1,48	18,40	48,84	7,37
Moduuli 599	21.4.17 5:50	18,57	59,25	9,04	9,80	28,22	2,44	10,68	24,77	2,27	18,42	48,87	7,39
Moduuli 599	21.4.17 6:50	18,60	59,30	9,07	9,32	22,68	1,90	10,24	19,20	1,71	18,46	48,87	7,40
Moduuli 599	21.4.17 7:50	18,64	59,39	9,10	8,85	20,93	1,70	9,79	17,89	1,55	18,48	48,93	7,42
Moduuli 599	21.4.17 8:50	18,82	59,39	9,20	8,68	20,50	1,64	9,62	17,63	1,51	18,64	48,99	7,51
Moduuli 599	21.4.17 9:50	19,01	59,33	9,30	8,68	20,44	1,64	9,60	17,56	1,50	18,82	48,96	7,59
Moduuli 599	21.4.17 10:50	19,15	59,28	9,38	8,75	20,54	1,65	9,68	17,63	1,51	18,96	48,93	7,65
Moduuli 599	21.4.17 11:50	19,35	59,22	9,49	8,84	20,57	1,67	9,76	17,56	1,51	19,13	48,99	7,74
Moduuli 599	21.4.17 12:50	18,97	58,85	9,21	8,84	20,31	1,65	9,82	17,50	1,51	18,79	48,66	7,53
Moduuli 599	21.4.17 13:50	19,08	59,36	9,35	10,08	28,35	2,50	10,94	24,64	2,30	18,88	49,08	7,63
Moduuli 599	21.4.17 14:50	19,57	59,28	9,63	9,74	22,84	1,97	10,62	19,13	1,75	19,36	49,08	7,87
Moduuli 599	21.4.17 15:50	19,97	59,14	9,84	9,51	21,15	1,79	10,39	17,82	1,60	19,75	49,08	8,06
Moduuli 599	21.4.17 16:50	20,43	58,94	10,09	9,58	20,63	1,76	10,44	17,53	1,58	20,18	49,02	8,27
Moduuli 599	21.4.17 17:50	20,70	58,57	10,20	9,74	20,37	1,75	10,62	17,36	1,59	20,44	48,93	8,38
Moduuli 599	21.4.17 18:50	20,90	58,42	10,30	9,91	20,31	1,77	10,79	17,36	1,60	20,66	48,90	8,49



Moduuli 599	21.4.17 19:50	20,96	58,22	10,30	10,02	20,11	1,76	10,92	17,17	1,60	20,70	48,81	8,50
Moduuli 599	21.4.17 20:50	20,90	58,08	10,24	10,10	19,98	1,76	11,02	17,36	1,63	20,68	48,78	8,48
Moduuli 599	21.4.17 21:50	20,79	58,02	10,16	11,44	27,87	2,69	12,31	24,39	2,49	20,59	48,75	8,43
Moduuli 599	21.4.17 22:50	20,53	58,08	10,01	10,89	22,06	2,05	11,83	18,55	1,84	20,35	48,69	8,30
Moduuli 599	21.4.17 23:50	20,20	58,14	9,82	10,26	20,44	1,82	11,26	17,33	1,65	20,04	48,72	8,15
Moduuli 599	22.4.17 0:50	19,89	58,19	9,64	9,84	20,11	1,74	10,87	17,23	1,60	19,74	48,69	7,99
Moduuli 599	22.4.17 1:50	19,60	58,22	9,47	9,56	20,18	1,72	10,58	17,30	1,58	19,46	48,66	7,85
Moduuli 599	22.4.17 2:50	19,36	58,31	9,35	9,31	20,37	1,70	10,36	17,50	1,57	19,20	48,63	7,72
Moduuli 599	22.4.17 3:50	19,14	58,39	9,23	9,10	20,37	1,68	10,14	17,50	1,55	18,99	48,60	7,61
Moduuli 599	22.4.17 4:50	18,96	58,48	9,14	8,92	20,37	1,66	9,96	17,73	1,55	18,80	48,60	7,52
Moduuli 599	22.4.17 5:50	18,88	58,62	9,12	10,16	29,11	2,58	11,08	25,54	2,41	18,73	48,63	7,49
Moduuli 599	22.4.17 6:50	18,92	58,76	9,16	9,64	23,10	1,98	10,58	19,46	1,77	18,76	48,69	7,52
Moduuli 599	22.4.17 7:50	18,94	58,85	9,19	9,12	21,32	1,76	10,10	18,15	1,60	18,79	48,69	7,53
Moduuli 599	22.4.17 8:50	18,94	58,91	9,20	8,88	20,89	1,70	9,86	17,89	1,55	18,78	48,69	7,53
Moduuli 599	22.4.17 9:50	19,00	58,93	9,24	8,80	20,83	1,68	9,78	17,82	1,54	18,82	48,72	7,55
Moduuli 599	22.4.17 10:50	19,11	58,93	9,30	8,77	20,86	1,68	9,76	17,89	1,54	18,94	48,69	7,60
Moduuli 599	22.4.17 11:50	19,16	58,91	9,32	8,80	20,83	1,68	9,77	17,82	1,54	19,02	48,69	7,64
Moduuli 599	22.4.17 12:50	19,20	58,93	9,35	8,82	20,63	1,67	9,80	17,82	1,54	19,04	48,72	7,65
Moduuli 599	22.4.17 13:50	19,51	58,96	9,54	10,24	28,95	2,58	11,08	25,35	2,39	19,31	48,81	7,80
Moduuli 599	22.4.17 14:50	19,61	59,02	9,61	9,90	23,03	2,00	10,80	19,40	1,79	19,40	48,81	7,84
Moduuli 599	22.4.17 15:50	19,85	58,96	9,74	9,56	21,22	1,81	10,48	18,02	1,63	19,62	48,84	7,96
Moduuli 599	22.4.17 16:50	20,03	58,82	9,83	9,49	20,76	1,76	10,40	17,69	1,59	19,80	48,81	8,04
Moduuli 599	22.4.17 17:50	20,13	58,71	9,87	9,52	20,70	1,76	10,44	17,63	1,59	19,90	48,78	8,08
Moduuli 599	22.4.17 18:50	20,09	58,65	9,84	9,52	20,70	1,76	10,46	17,69	1,60	19,89	48,75	8,07
Moduuli 599	22.4.17 19:50	20,01	58,59	9,78	9,50	20,70	1,75	10,46	17,63	1,59	19,80	48,72	8,03
Moduuli 599	22.4.17 20:50	19,86	58,62	9,69	9,45	20,50	1,73	10,42	17,69	1,59	19,68	48,75	7,97
Moduuli 599	22.4.17 21:50	19,77	58,71	9,65	10,70	28,79	2,64	11,58	25,16	2,45	19,56	48,75	7,91
Moduuli 599	22.4.17 22:50	19,63	58,74	9,57	10,20	22,97	2,04	11,14	19,27	1,82	19,46	48,75	7,86
Moduuli 599	22.4.17 23:50	19,48	58,79	9,49	9,63	21,28	1,82	10,61	18,02	1,64	19,32	48,75	7,79
Moduuli 599	23.4.17 0:50	19,34	58,85	9,42	9,32	20,96	1,75	10,30	17,82	1,59	19,15	48,78	7,72
Moduuli 599	23.4.17 1:50	19,23	58,91	9,37	9,13	20,99	1,73	10,11	17,89	1,58	19,05	48,78	7,67
Moduuli 599	23.4.17 2:50	19,15	58,91	9,32	8,99	21,09	1,73	9,97	17,96	1,57	18,97	48,78	7,63
Moduuli 599	23.4.17 3:50	19,08	58,96	9,29	8,90	21,22	1,73	9,89	18,05	1,57	18,90	48,75	7,59
Moduuli 599	23.4.17 4:50	19,01	59,02	9,26	8,79	20,99	1,70	9,80	18,02	1,56	18,82	48,78	7,56
Moduuli 599	23.4.17 5:50	18,96	59,13	9,24	10,02	29,24	2,57	10,92	25,61	2,39	18,81	48,81	7,56
Moduuli 599	23.4.17 6:50	18,96	59,22	9,26	9,60	23,61	2,01	10,54	19,82	1,80	18,81	48,81	7,56
Moduuli 599	23.4.17 7:50	18,98	59,28	9,28	9,14	21,87	1,81	10,10	18,48	1,63	18,80	48,87	7,56
Moduuli 599	23.4.17 8:50	19,02	59,33	9,31	8,87	21,35	1,73	9,84	18,02	1,56	18,82	48,90	7,58
Moduuli 599	23.4.17 9:50	19,04	59,30	9,32	8,78	21,22	1,71	9,72	17,95	1,54	18,86	48,90	7,60
Moduuli 599	23.4.17 10:50	19,13	59,33	9,37	8,80	21,44	1,73	9,76	18,22	1,57	18,95	48,93	7,64
Moduuli 599	23.4.17 11:50	19,36	59,31	9,51	8,84	21,48	1,74	9,79	18,25	1,58	19,15	48,93	7,74
Moduuli 599	23.4.17 12:50	19,59	59,25	9,63	8,98	21,28	1,74	9,92	18,32	1,60	19,36	48,93	7,84
Moduuli 599	23.4.17 13:50	19,76	59,28	9,74	10,24	28,35	2,52	11,08	24,90	2,34	19,56	48,96	7,95
Moduuli 599	23.4.17 14:50	20,06	59,16	9,90	10,06	23,19	2,04	10,93	19,53	1,82	19,84	48,96	8,08
Moduuli 599	23.4.17 15:50	20,18	59,05	9,96	9,80	21,48	1,86	10,69	18,25	1,67	19,98	48,96	8,15
Moduuli 599	23.4.17 16:50	20,49	58,97	10,14	9,74	21,02	1,81	10,64	17,89	1,64	20,23	48,99	8,29
Moduuli 599	23.4.17 17:50	20,48	58,74	10,09	9,80	20,99	1,81	10,72	17,96	1,65	20,25	48,90	8,28
Moduuli 599	23.4.17 18:50	20,45	58,65	10,06	9,82	20,89	1,81	10,73	17,89	1,65	20,21	48,87	8,26
Moduuli 599	23.4.17 19:50	20,30	58,59	9,95	9,78	20,89	1,80	10,72	17,89	1,64	20,10	48,81	8,19
Moduuli 599	23.4.17 20:50	20,09	58,56	9,82	9,66	20,63	1,77	10,66	17,82	1,63	19,91	48,81	8,09
Moduuli 599	23.4.17 21:50	19,90	58,65	9,72	10,82	28,92	2,68	11,74	25,54	2,51	19,73	48,81	8,00
Moduuli 599	23.4.17 22:50	19,72	58,74	9,63	10,33	23,23	2,08	11,28	19,53	1,86	19,56	48,81	7,92
Moduuli 599	23.4.17 23:50	19,48	58,82	9,50	9,72	21,48	1,85	10,72	18,22	1,67	19,32	48,84	7,81
Moduuli 599	24.4.17 0:50	19,26	58,88	9,38	9,34	21,09	1,77	10,36	18,02	1,62	19,11	48,84	7,71
Moduuli 599	24.4.17 1:50	19,06	58,99	9,28	9,11	21,22	1,75	10,12	18,09	1,60	18,90	48,81	7,60
Moduuli 599	24.4.17 2:50	18,86	59,05	9,17	8,89	21,28	1,73	9,91	18,22	1,59	18,71	48,81	7,51
Moduuli 599	24.4.17 3:50	18,72	59,16	9,11	8,74	21,48	1,73	9,75	18,35	1,58	18,57	48,81	7,45
Moduuli 599	24.4.17 4:50	18,67	59,28	9,10	8,60	21,25	1,69	9,60	18,32	1,56	18,50	48,87	7,42
Moduuli 599	24.4.17 5:50	18,68	59,36	9,12	9,82	29,87	2,59	10,71	26,37	2,42	18,52	48,87	7,43
Moduuli 599	24.4.17 6:50	18,74	59,45	9,17	9,43	24,10	2,03	10,36	20,24	1,82	18,56	48,93	7,46
Moduuli 599	24.4.17 7:50	18,78	59,53	9,20	8,96	22,19	1,81	9,93	18,81	1,64	18,60	48,96	7,48
Moduuli 599	24.4.17 8:50	18,90	59,50	9,27	8,78	21,64	1,75	9,72	18,41	1,58	18,72	48,99	7,54
Moduuli 599	24.4.17 9:50	18,96	59,53	9,31	8,74	21,57	1,74	9,68	18,41	1,58	18,78	48,99	7,57

Moduuli 599	24.4.17 10:50	19,12	59,53	9,40	8,76	21,48	1,73	9,69	18,35	1,57	18,91	49,02	7,64
Moduuli 599	24.4.17 11:50	19,18	59,31	9,40	8,84	21,48	1,74	9,76	18,41	1,59	18,99	48,87	7,65
Moduuli 599	24.4.17 12:50	19,14	59,50	9,41	8,80	21,15	1,71	9,75	18,18	1,57	18,96	49,05	7,67
Moduuli 599	24.4.17 13:50	19,46	59,53	9,60	10,15	29,65	2,62	10,97	26,18	2,45	19,26	49,14	7,83
Moduuli 599	24.4.17 14:50	19,64	59,48	9,70	9,92	23,74	2,07	10,79	19,98	1,85	19,45	49,11	7,91
Moduuli 599	24.4.17 15:50	19,94	59,48	9,88	9,58	21,70	1,85	10,50	18,41	1,67	19,72	49,17	8,06
Moduuli 599	24.4.17 16:50	20,09	59,34	9,95	9,52	21,09	1,79	10,43	17,96	1,62	19,88	49,11	8,13
Moduuli 599	24.4.17 17:50	20,07	59,22	9,92	9,54	21,02	1,79	10,45	17,96	1,62	19,88	49,08	8,12
Moduuli 599	24.4.17 18:50	20,02	59,14	9,87	9,52	20,89	1,77	10,46	17,89	1,62	19,81	49,05	8,08
Moduuli 599	24.4.17 19:50	19,97	59,11	9,84	9,51	20,89	1,77	10,45	17,96	1,62	19,76	49,05	8,06
Moduuli 599	24.4.17 20:50	19,87	59,14	9,78	9,44	20,70	1,75	10,41	17,89	1,61	19,68	49,05	8,02
Moduuli 599	24.4.17 21:50	19,77	59,16	9,73	10,66	29,24	2,68	11,54	25,93	2,52	19,59	49,05	7,97
Moduuli 599	24.4.17 22:50	19,68	59,25	9,69	10,26	23,39	2,09	11,18	19,69	1,87	19,50	49,08	7,93
Moduuli 599	24.4.17 23:50	19,50	59,31	9,59	9,67	21,48	1,84	10,64	18,22	1,67	19,34	49,08	7,86
Moduuli 599	25.4.17 0:50	19,33	59,33	9,49	9,34	21,06	1,76	10,32	17,96	1,61	19,16	49,08	7,77
Moduuli 599	25.4.17 1:50	19,16	59,39	9,40	9,14	21,09	1,74	10,11	18,02	1,59	19,00	49,11	7,70
Moduuli 599	25.4.17 2:50	19,02	59,45	9,33	8,96	21,12	1,73	9,94	18,09	1,58	18,86	49,11	7,63
Moduuli 599	25.4.17 3:50	18,87	59,48	9,25	8,82	21,25	1,72	9,82	18,22	1,58	18,70	49,11	7,55
Moduuli 599	25.4.17 4:50	18,75	59,59	9,19	8,68	21,06	1,69	9,67	18,15	1,56	18,58	49,11	7,50
Moduuli 599	25.4.17 5:50	18,68	59,76	9,18	9,84	29,81	2,58	10,73	26,37	2,43	18,52	49,16	7,48
Moduuli 599	25.4.17 6:50	18,69	59,87	9,20	9,49	24,00	2,03	10,40	20,21	1,82	18,54	49,16	7,49
Moduuli 599	25.4.17 7:50	18,70	59,96	9,22	8,96	22,06	1,80	9,92	18,68	1,63	18,52	49,25	7,49
Moduuli 599	25.4.17 8:50	18,73	60,02	9,25	8,74	21,48	1,73	9,68	18,28	1,57	18,55	49,25	7,51
Moduuli 599	25.4.17 9:50	18,76	60,07	9,27	8,65	21,48	1,72	9,60	18,38	1,57	18,58	49,28	7,52
Moduuli 599	25.4.17 10:50	18,85	60,10	9,33	8,63	21,41	1,71	9,56	18,28	1,56	18,70	49,34	7,59
Moduuli 599	25.4.17 11:50	19,00	60,16	9,43	8,66	21,48	1,72	9,61	18,35	1,57	18,83	49,37	7,66
Moduuli 599	25.4.17 12:50	19,12	60,13	9,49	8,72	21,22	1,71	9,66	18,22	1,56	18,94	49,37	7,71
Moduuli 599	25.4.17 13:50	19,32	60,19	9,62	10,04	29,68	2,61	10,86	26,25	2,44	19,13	49,43	7,81
Moduuli 599	25.4.17 14:50	19,54	60,16	9,75	9,84	23,74	2,06	10,71	19,85	1,82	19,35	49,43	7,92
Moduuli 599	25.4.17 15:50	19,80	60,02	9,89	9,39	21,35	1,80	10,28	17,92	1,60	19,60	49,46	8,05
Moduuli 599	25.4.17 16:50	19,76	59,96	9,85	9,24	20,89	1,74	10,15	17,63	1,56	19,60	49,46	8,05
Moduuli 599	25.4.17 17:50	19,68	59,88	9,79	9,16	20,83	1,72	10,09	17,59	1,55	19,50	49,40	7,99
Moduuli 599	25.4.17 18:50	19,58	59,85	9,72	9,08	20,96	1,73	10,02	17,69	1,55	19,40	49,43	7,94
Moduuli 599	25.4.17 19:50	19,50	59,82	9,67	9,00	21,09	1,73	9,97	17,89	1,56	19,32	49,43	7,90
Moduuli 599	25.4.17 20:50	19,36	59,85	9,59	8,95	21,09	1,72	9,93	18,09	1,58	19,20	49,46	7,85
Moduuli 599	25.4.17 21:50	19,28	59,87	9,55	9,98	28,32	2,48	10,86	25,22	2,34	19,13	49,46	7,81
Moduuli 599	25.4.17 22:50	19,22	59,96	9,53	9,66	23,42	2,01	10,58	19,66	1,79	19,06	49,46	7,78
Moduuli 599	25.4.17 23:50	19,09	59,99	9,45	9,14	21,77	1,80	10,11	18,41	1,63	18,96	49,52	7,74
Moduuli 599	26.4.17 0:50	18,98	60,02	9,39	8,86	21,41	1,74	9,84	18,15	1,57	18,82	49,52	7,67
Moduuli 599	26.4.17 1:50	18,86	60,07	9,33	8,66	21,41	1,71	9,65	18,09	1,55	18,71	49,52	7,62
Moduuli 599	26.4.17 2:50	18,75	60,10	9,27	8,54	21,54	1,71	9,52	18,22	1,55	18,60	49,52	7,57
Moduuli 599	26.4.17 3:50	18,66	60,13	9,23	8,44	21,67	1,71	9,42	18,38	1,55	18,50	49,52	7,52
Moduuli 599	26.4.17 4:50	18,60	60,21	9,20	8,38	21,67	1,70	9,35	18,51	1,55	18,46	49,52	7,50
Moduuli 599	26.4.17 5:50	18,60	60,36	9,23	9,63	30,91	2,64	10,52	27,52	2,50	18,48	49,58	7,52
Moduuli 599	26.4.17 6:50	18,67	60,44	9,28	9,32	24,58	2,06	10,24	20,57	1,83	18,54	49,61	7,55
Moduuli 599	26.4.17 7:50	18,67	60,53	9,29	8,80	22,38	1,81	9,75	18,87	1,63	18,54	49,67	7,56
Moduuli 599	26.4.17 8:50	18,79	60,56	9,37	8,58	21,80	1,74	9,52	18,41	1,56	18,61	49,70	7,60
Moduuli 599	26.4.17 9:50	18,90	60,56	9,43	8,52	21,67	1,72	9,45	18,28	1,54	18,74	49,73	7,67
Moduuli 599	26.4.17 10:50	19,10	60,50	9,54	8,58	21,67	1,73	9,48	18,41	1,56	18,92	49,73	7,75
Moduuli 599	26.4.17 11:50	19,26	60,47	9,63	8,66	21,74	1,74	9,56	18,48	1,57	19,08	49,73	7,83
Moduuli 599	26.4.17 12:50	19,42	60,39	9,71	8,76	21,51	1,73	9,67	18,48	1,58	19,22	49,76	7,91
Moduuli 599	26.4.17 13:50	19,65	60,36	9,85	9,93	28,67	2,50	10,76	25,54	2,35	19,46	49,79	8,03
Moduuli 599	26.4.17 14:50	19,78	60,30	9,92	9,84	23,48	2,04	10,70	19,79	1,82	19,62	49,76	8,10
Moduuli 599	26.4.17 15:50	19,83	60,19	9,93	9,48	21,67	1,83	10,40	18,41	1,66	19,66	49,76	8,12
Moduuli 599	26.4.17 16:50	19,78	60,10	9,89	9,32	21,15	1,77	10,26	18,02	1,61	19,59	49,76	8,09
Moduuli 599	26.4.17 17:50	19,68	60,13	9,83	9,20	21,02	1,75	10,15	17,89	1,58	19,51	49,79	8,05
Moduuli 599	26.4.17 18:50	19,60	60,07	9,77	9,12	21,06	1,74	10,06	17,96	1,58	19,44	49,79	8,02
Moduuli 599	26.4.17 19:50	19,52	60,02	9,72	9,06	21,15	1,74	10,02	18,09	1,59	19,35	49,76	7,97
Moduuli 599	26.4.17 20:50	19,44	60,05	9,67	9,00	21,09	1,73	9,96	18,22	1,59	19,28	49,76	7,94
Moduuli 599	26.4.17 21:50	19,38	60,13	9,65	10,04	28,73	2,52	10,93	25,73	2,40	19,22	49,79	7,91
Moduuli 599	26.4.17 22:50	19,34	60,19	9,63	9,76	23,55	2,03	10,69	19,88	1,82	19,20	49,76	7,90
Moduuli 599	26.4.17 23:50	19,22	60,22	9,57	9,24	21,77	1,81	10,22	18,55	1,65	19,07	49,79	7,84
Moduuli 599	27.4.17 0:50	19,13	60,22	9,51	8,98	21,35	1,75	9,94	18,22	1,59	18,98	49,79	7,79

Moduuli 599	27.4.17 1:50	19,03	60,27	9,46	8,80	21,28	1,72	9,78	18,09	1,56	18,86	49,79	7,73
Moduuli 599	27.4.17 2:50	18,96	60,30	9,43	8,68	21,35	1,71	9,64	18,15	1,55	18,79	49,79	7,70
Moduuli 599	27.4.17 3:50	18,86	60,36	9,38	8,60	21,48	1,71	9,54	18,28	1,55	18,72	49,76	7,66
Moduuli 599	27.4.17 4:50	18,80	60,41	9,35	8,52	21,48	1,70	9,48	18,45	1,56	18,64	49,82	7,63
Moduuli 599	27.4.17 5:50	18,75	60,53	9,34	9,76	30,91	2,67	10,65	27,71	2,54	18,62	49,87	7,63
Moduuli 599	27.4.17 6:50	18,81	60,64	9,39	9,48	24,58	2,08	10,39	20,63	1,86	18,67	49,87	7,66
Moduuli 599	27.4.17 7:50	18,84	60,67	9,41	8,95	22,29	1,82	9,89	18,87	1,64	18,70	49,90	7,68
Moduuli 599	27.4.17 8:50	18,89	60,70	9,45	8,70	21,67	1,74	9,66	18,41	1,58	18,73	49,93	7,69
Moduuli 599	27.4.17 9:50	19,06	60,67	9,54	8,66	21,48	1,72	9,57	18,22	1,55	18,90	49,96	7,78
Moduuli 599	27.4.17 10:50	19,30	60,61	9,68	8,70	21,48	1,72	9,60	18,28	1,56	19,10	49,99	7,88
Moduuli 599	27.4.17 11:50	19,58	60,53	9,83	8,84	21,48	1,74	9,71	18,35	1,58	19,36	49,96	8,01
Moduuli 599	27.4.17 12:50	19,89	60,39	10,00	9,02	21,28	1,75	9,89	18,35	1,60	19,66	49,99	8,16
Moduuli 599	27.4.17 13:50	20,08	60,42	10,13	10,18	28,19	2,50	10,99	25,35	2,37	19,84	50,02	8,26
Moduuli 599	27.4.17 14:50	20,26	60,22	10,20	10,18	23,29	2,07	11,01	19,66	1,84	20,05	49,97	8,36
Moduuli 599	27.4.17 15:50	20,44	60,13	10,30	9,86	21,35	1,85	10,73	18,22	1,68	20,21	49,99	8,45
Moduuli 599	27.4.17 16:50	20,55	59,96	10,35	9,79	20,76	1,79	10,67	17,82	1,63	20,31	49,94	8,49
Moduuli 599	27.4.17 17:50	20,56	59,88	10,34	9,76	20,57	1,77	10,64	17,63	1,61	20,34	50,00	8,51
Moduuli 599	27.4.17 18:50	20,67	59,79	10,39	9,78	20,57	1,78	10,68	17,69	1,62	20,45	49,97	8,57
Moduuli 599	27.4.17 19:50	20,76	59,65	10,42	9,84	20,63	1,79	10,74	17,82	1,64	20,55	49,85	8,60
Moduuli 599	27.4.17 20:50	20,64	59,62	10,34	9,86	20,47	1,78	10,77	17,79	1,64	20,45	49,82	8,54
Moduuli 599	27.4.17 21:50	20,45	59,71	10,24	10,80	27,46	2,54	11,67	24,90	2,44	20,25	49,82	8,44
Moduuli 599	27.4.17 22:50	20,24	59,85	10,13	10,54	22,81	2,07	11,46	19,33	1,87	20,08	49,82	8,35
Moduuli 599	27.4.17 23:50	19,97	59,99	9,99	9,96	21,02	1,84	10,92	18,02	1,68	19,82	49,88	8,23
Moduuli 599	28.4.17 0:50	19,69	60,05	9,82	9,56	20,70	1,76	10,56	17,76	1,62	19,54	49,88	8,08
Moduuli 599	28.4.17 1:50	19,45	60,10	9,69	9,27	20,63	1,72	10,27	17,76	1,58	19,28	49,88	7,95
Moduuli 599	28.4.17 2:50	19,20	60,19	9,55	9,05	20,76	1,71	10,04	17,89	1,57	19,06	49,88	7,85
Moduuli 599	28.4.17 3:50	19,00	60,22	9,44	8,86	20,96	1,70	9,86	18,09	1,57	18,86	49,87	7,75
Moduuli 599	28.4.17 4:50	18,81	60,36	9,35	8,70	21,02	1,69	9,70	18,28	1,57	18,68	49,90	7,67
Moduuli 599	28.4.17 5:50	18,78	60,50	9,35	9,56	28,06	2,39	10,48	25,41	2,30	18,62	49,93	7,64
Moduuli 599	28.4.17 6:50	18,84	60,64	9,41	9,38	23,71	1,99	10,30	20,05	1,79	18,68	49,96	7,68
Moduuli 599	28.4.17 7:50	18,88	60,70	9,44	8,93	21,80	1,78	9,86	18,68	1,62	18,72	49,99	7,70
Moduuli 599	28.4.17 8:50	18,55	60,81	9,27	8,64	21,35	1,71	9,60	18,35	1,57	18,40	50,02	7,55
Moduuli 599	28.4.17 9:50	18,69	60,90	9,36	8,50	21,22	1,68	9,43	18,22	1,54	18,54	50,14	7,64
Moduuli 599	28.4.17 10:50	18,95	60,87	9,51	8,50	21,22	1,68	9,41	18,15	1,53	18,77	50,14	7,75
Moduuli 599	28.4.17 11:50	19,16	60,78	9,62	8,59	21,22	1,69	9,47	18,18	1,54	18,97	50,08	7,83
Moduuli 599	28.4.17 12:50	19,42	60,78	9,78	8,71	21,09	1,69	9,60	18,22	1,55	19,21	50,17	7,97
Moduuli 599	28.4.17 13:50	19,83	60,78	10,03	10,18	30,12	2,67	10,96	27,33	2,55	19,61	50,20	8,17
Moduuli 599	28.4.17 14:50	20,26	60,67	10,28	10,22	24,00	2,13	11,02	20,24	1,90	20,03	50,20	8,39
Moduuli 599	28.4.17 15:50	20,53	60,50	10,43	9,89	21,25	1,85	10,70	18,09	1,66	20,30	50,23	8,53
Moduuli 599	28.4.17 16:50	20,75	60,33	10,54	9,84	20,50	1,78	10,68	17,56	1,61	20,51	50,26	8,65
Moduuli 599	28.4.17 17:50	20,82	60,10	10,54	9,92	20,24	1,76	10,74	17,56	1,62	20,58	50,17	8,67
Moduuli 599	28.4.17 18:50	20,86	60,02	10,55	9,98	20,24	1,77	10,81	17,63	1,63	20,62	50,17	8,69
Moduuli 599	28.4.17 19:50	20,85	59,93	10,53	9,99	20,11	1,76	10,86	17,43	1,62	20,63	50,11	8,69
Moduuli 599	28.4.17 20:50	20,75	59,93	10,47	9,96	19,85	1,73	10,85	17,27	1,60	20,52	50,08	8,62
Moduuli 599	28.4.17 21:50	20,54	60,10	10,36	10,99	27,90	2,61	11,86	25,54	2,53	20,40	50,08	8,56
Moduuli 599	28.4.17 22:50	20,38	60,27	10,29	10,77	22,84	2,11	11,67	19,40	1,90	20,21	50,11	8,47
Moduuli 599	28.4.17 23:50	20,16	60,39	10,17	10,14	20,73	1,83	11,08	17,82	1,68	20,00	50,14	8,36
Moduuli 599	29.4.17 0:50	19,91	60,47	10,03	9,74	20,18	1,74	10,70	17,43	1,60	19,76	50,17	8,24
Moduuli 599	29.4.17 1:50	19,67	60,53	9,89	9,45	20,11	1,70	10,42	17,43	1,57	19,52	50,20	8,13
Moduuli 599	29.4.17 2:50	19,45	60,58	9,76	9,25	20,24	1,69	10,22	17,63	1,57	19,30	50,20	8,02
Moduuli 599	29.4.17 3:50	19,24	60,64	9,65	9,08	20,44	1,68	10,05	17,86	1,57	19,10	50,20	7,92
Moduuli 599	29.4.17 4:50	19,07	60,70	9,55	8,90	20,44	1,66	9,89	17,82	1,55	18,91	50,20	7,82
Moduuli 599	29.4.17 5:50	18,93	60,84	9,49	9,76	27,78	2,39	10,66	25,35	2,32	18,78	50,26	7,77
Moduuli 599	29.4.17 6:50	18,90	61,01	9,50	9,56	23,48	2,00	10,50	19,95	1,81	18,76	50,29	7,76
Moduuli 599	29.4.17 7:50	18,89	61,07	9,50	9,02	21,38	1,75	9,96	18,41	1,61	18,76	50,32	7,77
Moduuli 599	29.4.17 8:50	18,93	61,09	9,53	8,80	20,89	1,69	9,73	18,02	1,55	18,78	50,32	7,78
Moduuli 599	29.4.17 9:50	19,00	61,09	9,57	8,69	20,70	1,66	9,62	17,89	1,53	18,83	50,35	7,81
Moduuli 599	29.4.17 10:50	19,10	61,09	9,63	8,67	20,70	1,66	9,58	17,89	1,52	18,93	50,35	7,86
Moduuli 599	29.4.17 11:50	19,18	61,09	9,68	8,70	20,76	1,67	9,60	17,95	1,53	19,02	50,38	7,91
Moduuli 599	29.4.17 12:50	19,22	61,07	9,70	8,75	20,70	1,67	9,66	18,02	1,54	19,06	50,38	7,92
Moduuli 599	29.4.17 13:50	19,26	61,12	9,74	9,72	27,27	2,34	10,55	24,84	2,26	19,10	50,41	7,95
Moduuli 599	29.4.17 14:50	19,34	61,18	9,79	9,68	23,29	2,00	10,57	19,79	1,80	19,18	50,44	7,99
Moduuli 599	29.4.17 15:50	19,36	61,18	9,81	9,26	21,28	1,77	10,16	18,22	1,61	19,21	50,47	8,01

Moduuli 599	29.4.17 16:50	19,35	61,15	9,79	9,08	20,83	1,72	10,00	17,96	1,57	19,18	50,47	8,00
Moduuli 599	29.4.17 17:50	19,30	61,09	9,76	8,98	20,63	1,69	9,88	17,76	1,54	19,14	50,47	7,98
Moduuli 599	29.4.17 18:50	19,24	61,07	9,71	8,87	20,57	1,67	9,82	17,69	1,53	19,08	50,47	7,95
Moduuli 599	29.4.17 19:50	19,18	61,07	9,68	8,81	20,63	1,67	9,74	17,69	1,52	19,01	50,47	7,91
Moduuli 599	29.4.17 20:50	19,11	61,07	9,64	8,74	20,63	1,66	9,68	17,76	1,52	18,93	50,47	7,87
Moduuli 599	29.4.17 21:50	19,06	61,18	9,62	9,90	29,81	2,59	10,78	27,08	2,50	18,90	50,52	7,87
Moduuli 599	29.4.17 22:50	19,05	61,29	9,64	9,77	24,26	2,09	10,68	20,37	1,87	18,89	50,52	7,86
Moduuli 599	29.4.17 23:50	18,98	61,32	9,60	9,17	21,67	1,80	10,10	18,41	1,62	18,83	50,55	7,84
Moduuli 599	30.4.17 0:50	18,90	61,38	9,56	8,86	20,96	1,70	9,80	17,92	1,55	18,75	50,58	7,80
Moduuli 599	30.4.17 1:50	18,82	61,40	9,52	8,68	20,83	1,67	9,61	17,76	1,52	18,66	50,58	7,76
Moduuli 599	30.4.17 2:50	18,76	61,40	9,48	8,56	20,86	1,66	9,50	17,89	1,52	18,62	50,58	7,74
Moduuli 599	30.4.17 3:50	18,74	61,40	9,47	8,50	20,96	1,66	9,44	18,02	1,52	18,58	50,58	7,72
Moduuli 599	30.4.17 4:50	18,71	61,43	9,46	8,46	21,02	1,66	9,40	18,12	1,52	18,56	50,58	7,71
Moduuli 599	30.4.17 5:50	18,70	61,52	9,46	9,37	27,97	2,35	10,24	25,29	2,25	18,58	50,58	7,72
Moduuli 599	30.4.17 6:50	18,76	61,60	9,51	9,36	23,90	2,01	10,24	20,15	1,79	18,63	50,64	7,76
Moduuli 599	30.4.17 7:50	18,77	61,63	9,52	8,88	21,74	1,77	9,79	18,48	1,60	18,62	50,67	7,76
Moduuli 599	30.4.17 8:50	18,76	61,66	9,52	8,67	21,28	1,71	9,60	18,18	1,55	18,60	50,64	7,74
Moduuli 599	30.4.17 9:50	18,80	61,66	9,54	8,56	21,12	1,68	9,48	18,02	1,52	18,65	50,73	7,78
Moduuli 599	30.4.17 10:50	18,92	61,60	9,61	8,54	21,09	1,67	9,45	17,99	1,52	18,74	50,70	7,82
Moduuli 599	30.4.17 11:50	19,02	61,55	9,66	8,57	21,15	1,68	9,47	18,02	1,52	18,87	50,70	7,88
Moduuli 599	30.4.17 12:50	19,13	61,49	9,72	8,63	21,06	1,68	9,53	18,02	1,53	18,96	50,70	7,93
Moduuli 599	30.4.17 13:50	19,30	61,57	9,83	9,80	29,11	2,52	10,63	26,37	2,41	19,13	50,76	8,02
Moduuli 599	30.4.17 14:50	19,47	61,63	9,95	9,86	24,22	2,10	10,70	20,37	1,87	19,31	50,76	8,11
Moduuli 599	30.4.17 15:50	19,67	61,49	10,05	9,46	21,74	1,84	10,32	18,45	1,65	19,47	50,76	8,19
Moduuli 599	30.4.17 16:50	19,76	61,46	10,10	9,30	21,09	1,76	10,18	17,96	1,59	19,56	50,82	8,25
Moduuli 599	30.4.17 17:50	19,78	61,26	10,08	9,26	20,89	1,74	10,14	17,76	1,57	19,57	50,76	8,24
Moduuli 599	30.4.17 18:50	19,74	61,12	10,03	9,24	20,89	1,74	10,12	17,89	1,58	19,54	50,67	8,21
Moduuli 599	30.4.17 19:50	19,61	61,12	9,95	9,18	21,02	1,74	10,09	18,02	1,59	19,44	50,70	8,17
Moduuli 599	30.4.17 20:50	19,49	61,09	9,87	9,13	21,02	1,74	10,04	18,02	1,58	19,30	50,70	8,10
Moduuli 599	30.4.17 21:50	19,37	61,15	9,81	9,94	27,97	2,44	10,83	25,35	2,35	19,20	50,70	8,05
Moduuli 599	30.4.17 22:50	19,26	61,29	9,76	9,88	24,00	2,09	10,78	20,15	1,86	19,10	50,67	7,99
Moduuli 599	30.4.17 23:50	19,12	61,32	9,68	9,30	21,80	1,82	10,24	18,48	1,65	18,95	50,70	7,92

## Sensor Data Report - 08.05.2017 to 15.05.2017

Modul	Date	T1	RH1	AH 1	T2	RH2	AH 2	T3	RH3	AH 3	T4	RH4	AH 4
Moduuli_222	8.5.17 0:17	19,14	17,27	2,73	10,24	26,67	2,37		80,17		-13,40	87,12	1,36
Moduuli_222	8.5.17 1:17	18,98	17,19	2,69	9,90	26,94	2,34				-13,86	86,52	1,30
Moduuli_222	8.5.17 2:17	18,82	17,14	2,66	9,67	26,96	2,31		80,15		-14,46	86,66	1,24
Moduuli_222	8.5.17 3:17	18,66	17,09	2,62	9,49	26,91	2,28	-14,46	88,13	1,26	-13,81	86,96	1,31
Moduuli_222	8.5.17 4:17	18,50	17,04	2,59	9,34	26,89	2,25		79,94		-13,06	87,01	1,39
Moduuli_222	8.5.17 5:17	18,34	16,92	2,54	9,16	26,83	2,22	-10,46	88,73	1,75	-8,54	88,34	2,03
Moduuli_222	8.5.17 6:17	18,42	17,99	2,72	10,16	28,72	2,54	-10,80	89,24	1,71	-10,98	85,04	1,61
Moduuli_222	8.5.17 7:17	18,55	17,64	2,69	10,08	26,90	2,37		80,08				
Moduuli_222	8.5.17 8:17	18,62	17,53	2,68	9,69	27,16	2,33	-14,07					
Moduuli_222	8.5.17 9:17	18,68	17,42	2,68	9,54	27,42	2,33	-13,40			-12,00	86,58	1,51
Moduuli_222	8.5.17 10:17	18,77	17,55	2,71	9,73	27,89	2,40	-10,90	89,02	1,70	-7,67	86,37	2,12
Moduuli_222	8.5.17 11:17	18,45	17,61	2,67	10,40	28,04	2,52	-6,58	89,72	2,40	-1,68	86,47	3,34
Moduuli_222	8.5.17 12:17	16,68	17,58	2,38	10,29	26,31	2,35	-6,26	89,25	2,44	-1,31	86,25	3,42
Moduuli_222	8.5.17 13:17	17,58	18,45	2,64	10,43	27,77	2,50	-5,84	88,77	2,51	-0,93	86,22	3,52
Moduuli_222	8.5.17 14:17	17,62	18,72	2,69	10,68	27,91	2,56	-5,36	87,96	2,58	-0,55	86,17	3,61
Moduuli_222	8.5.17 15:17	18,41	19,16	2,89	11,18	28,76	2,73	-6,57	84,40	2,26	-4,30	82,71	2,63
Moduuli_222	8.5.17 16:17	19,00	18,63	2,92	10,75	27,33	2,52	-13,06	87,15	1,40	-12,90	87,16	1,41
Moduuli_222	8.5.17 17:17	19,28	18,13	2,89	10,16	27,68	2,45	-13,57	88,22	1,36	-13,28	88,03	1,39
Moduuli_222	8.5.17 18:17	19,34	17,76	2,84	9,88	27,72	2,41				-13,52	88,38	1,36
Moduuli_222	8.5.17 19:17	19,41	17,39	2,80	9,73	27,33	2,35				-12,86	88,73	1,44
Moduuli_222	8.5.17 20:17	19,46	18,06	2,91	10,53	29,87	2,71	-8,69	83,39	1,89	-9,05	84,59	1,87
Moduuli_222	8.5.17 21:17	19,46	17,37	2,80	10,60	26,47	2,41	-12,60	86,68	1,44	-12,44	88,08	1,48
Moduuli_222	8.5.17 22:17	19,30	16,89	2,70	10,14	26,13	2,31	-13,08	87,34	1,40	-12,76	88,50	1,45
Moduuli_222	8.5.17 23:17	19,11	16,57	2,62	9,78	25,96	2,24	-13,60	87,41	1,34	-13,20	88,64	1,40
Moduuli_222	9.5.17 0:17	18,92	16,28	2,54	9,55	25,66	2,18				-13,68	88,56	1,35
Moduuli_222	9.5.17 1:17	18,71	16,02	2,47	9,35	25,31	2,12	-13,84			-13,36	88,76	1,39
Moduuli_222	9.5.17 2:17	18,55	15,81	2,41	9,18	25,01	2,07				-13,08	89,13	1,43
Moduuli_222	9.5.17 3:17	18,47	15,62	2,37	9,02	24,74	2,03				-13,00	89,29	1,44
Moduuli_222	9.5.17 4:17	18,44	16,49	2,50	9,77	27,65	2,39	-8,62	81,23	1,85	-8,84	85,38	1,91
Moduuli_222	9.5.17 5:17	18,44	16,16	2,45	9,86	24,84	2,16	-12,94	84,47	1,37	-12,68	88,71	1,47
Moduuli_222	9.5.17 6:17	18,36	16,01	2,41	9,40	24,95	2,10				-13,30	89,27	1,40
Moduuli_222	9.5.17 7:17	18,32	16,00	2,40	9,12	25,34	2,09	-14,04	84,94	1,26	-13,74	89,53	1,36
Moduuli_222	9.5.17 8:17	18,32	16,06	2,41	8,98	25,58	2,09	-13,54	85,91	1,32	-12,69	90,00	1,49
Moduuli_222	9.5.17 9:17	18,42	16,19	2,45	8,93	25,91	2,11	-14,24	85,78	1,25	-13,60	89,80	1,38
Moduuli_222	9.5.17 10:17	18,50	16,32	2,48	8,92	26,25	2,14	-13,82	85,72	1,29	-12,92	89,74	1,45
Moduuli_222	9.5.17 11:17	18,62	16,42	2,51	8,91	26,22	2,13				-12,68	89,49	1,48
Moduuli_222	9.5.17 12:17	18,86	17,54	2,73	9,86	29,63	2,57	-8,42	80,57	1,87	-8,64	88,38	2,01
Moduuli_222	9.5.17 13:17	19,10	17,42	2,75	10,15	26,77	2,37						
Moduuli_222	9.5.17 14:17	19,13	17,30	2,73	9,79	27,03	2,34	-13,62	85,50	1,31	-13,20	89,14	1,41
Moduuli_222	9.5.17 15:17	19,19	17,38	2,76	9,62	27,48	2,35	-13,99	85,72	1,27	-13,62	88,96	1,36
Moduuli_222	9.5.17 16:17	19,24	17,40	2,77	9,56	27,81	2,37	-13,36	86,73	1,36	-12,50	89,22	1,50
Moduuli_222	9.5.17 17:17	19,24	17,47	2,78	9,50	27,76	2,35	-14,09	86,87	1,28	-13,28	89,02	1,40
Moduuli_222	9.5.17 18:17	19,26	17,47	2,78	9,48	27,94	2,36	-14,30	86,48	1,25	-13,62	88,84	1,36
Moduuli_222	9.5.17 19:17	19,28	17,48	2,79	9,44	27,77	2,34				-12,32	88,99	1,51
Moduuli_222	9.5.17 20:17	19,31	18,53	2,96	10,30	30,89	2,76	-8,32	80,98	1,89	-8,42	89,94	2,08
Moduuli_222	9.5.17 21:17	19,30	18,14	2,90	10,44	27,64	2,49				-12,64	89,03	1,48
Moduuli_222	9.5.17 22:17	19,18	17,97	2,85	9,96	27,84	2,43				-13,18	88,81	1,41
Moduuli_222	9.5.17 23:17	19,04	17,96	2,82	9,64	28,15	2,41	-13,97	86,34	1,28	-13,56	88,55	1,36
Moduuli_222	10.5.17 0:17	18,92	17,92	2,79	9,45	28,40	2,40	-13,38	87,19	1,36	-12,49	88,70	1,49
Moduuli_222	10.5.17 1:17	18,81	17,92	2,78	9,29	28,32	2,37	-14,12	87,34	1,28	-13,29	88,40	1,39
Moduuli_222	10.5.17 2:17	18,70	17,95	2,76	9,17	28,47	2,36	-14,32	86,80	1,25	-13,64	88,29	1,35
Moduuli_222	10.5.17 3:17	18,60	17,92	2,74	9,04	28,30	2,33	-13,56	87,59	1,35	-12,42	88,25	1,49
Moduuli_222	10.5.17 4:17	18,57	19,02	2,90	9,83	31,70	2,75	-8,01	80,88	1,93	-8,12	90,55	2,15
Moduuli_222	10.5.17 5:17	18,56	18,69	2,85	9,98	28,35	2,48				-12,70	88,73	1,46
Moduuli_222	10.5.17 6:17	18,48	18,60	2,82	9,48	28,63	2,42						
Moduuli_222	10.5.17 7:17	18,46	18,59	2,82	9,20	29,17	2,42				-13,62	88,25	1,35
Moduuli_222	10.5.17 8:17	18,44	18,59	2,81	9,03	29,43	2,42				-12,57	88,30	1,47
Moduuli_222	10.5.17 9:17	18,36	18,56	2,80	8,96	29,47	2,41	-14,20	87,60	1,28	-13,50	88,10	1,36

Moduuli_222	10.5.17 10:17	18,45	18,72	2,83	8,90	29,79	2,42	-13,93			-13,08	88,23	1,41
Moduuli_222	10.5.17 11:17	18,57	18,73	2,86	8,88	29,76	2,42	-13,90			-12,87	88,06	1,43
Moduuli_222	10.5.17 12:17	18,74	19,85	3,06	9,76	33,20	2,86	-7,96	81,56	1,96	-8,04	90,67	2,16
Moduuli_222	10.5.17 13:17	18,98	19,54	3,06	10,08	29,94	2,64				-12,62	88,64	1,47
Moduuli_222	10.5.17 14:17	19,13	19,52	3,08	9,74	30,34	2,61						
Moduuli_222	10.5.17 15:17	19,33	19,52	3,12	9,63	30,86	2,64				-13,56	88,18	1,36
Moduuli_222	10.5.17 16:17	19,42	19,48	3,13	9,60	31,13	2,66	-13,58	88,36	1,36	-12,87	88,35	1,44
Moduuli_222	10.5.17 17:17	19,52	19,45	3,15	9,62	31,08	2,65	-13,92	88,95	1,33	-13,03	88,11	1,41
Moduuli_222	10.5.17 18:17	19,49	19,41	3,14	9,61	31,04	2,65	-14,36			-13,62	88,02	1,35
Moduuli_222	10.5.17 19:17	19,56	19,33	3,14	9,58	30,85	2,63	-13,35	89,37	1,40	-12,03	88,19	1,54
Moduuli_222	10.5.17 20:17	19,64	20,46	3,34	10,50	34,20	3,10	-7,37	82,46	2,07	-7,36	91,73	2,31
Moduuli_222	10.5.17 21:17	19,68	19,95	3,26	10,72	30,39	2,79	-12,88	87,07	1,42	-12,55	88,82	1,48
Moduuli_222	10.5.17 22:17	19,56	19,72	3,20	10,22	30,46	2,71	-13,54	88,13	1,36	-13,12	88,41	1,41
Moduuli_222	10.5.17 23:17	19,44	19,62	3,16	9,92	30,77	2,68	-13,90			-13,46	88,25	1,37
Moduuli_222	11.5.17 0:17	19,25	19,49	3,10	9,71	30,83	2,65				-13,12	88,32	1,41
Moduuli_222	11.5.17 1:17	19,11	19,42	3,06	9,52	30,67	2,60				-12,80	88,09	1,44
Moduuli_222	11.5.17 2:17	18,98	19,41	3,04	9,38	30,69	2,58				-13,60	87,93	1,35
Moduuli_222	11.5.17 3:17	18,82	19,29	2,99	9,23	30,49	2,54	-13,38	89,45	1,40	-12,08	88,05	1,53
Moduuli_222	11.5.17 4:17	18,77	20,42	3,15	10,01	34,04	2,98	-7,07	82,63	2,12	-6,98	91,80	2,38
Moduuli_222	11.5.17 5:17	18,75	20,05	3,09	10,18	30,23	2,68	-12,88	86,97	1,41	-12,60	88,69	1,47
Moduuli_222	11.5.17 6:17	18,62	19,82	3,03	9,63	30,43	2,60				-13,24	88,18	1,39
Moduuli_222	11.5.17 7:17	18,59	19,81	3,03	9,32	30,95	2,59	-13,96					
Moduuli_222	11.5.17 8:17	18,57	19,80	3,02	9,15	31,33	2,59	-13,40	88,98	1,39	-12,58	88,11	1,47
Moduuli_222	11.5.17 9:17	18,64	19,82	3,04	9,08	31,37	2,58				-13,20	87,82	1,39
Moduuli_222	11.5.17 10:17	18,64	19,76	3,03	9,04	31,49	2,59				-13,74	87,79	1,33
Moduuli_222	11.5.17 11:17	18,79	19,74	3,05	9,02	31,48	2,58	-13,72	89,44	1,36	-12,60	87,82	1,46
Moduuli_222	11.5.17 12:17	19,02	20,92	3,28	9,92	35,15	3,06	-7,15	83,04	2,12	-7,10	91,57	2,35
Moduuli_222	11.5.17 13:17	19,30	20,55	3,28	10,30	31,51	2,82	-12,98	87,41	1,41	-12,72	88,58	1,46
Moduuli_222	11.5.17 14:17	19,46	20,40	3,29	9,96	31,77	2,78	-13,65	88,48	1,35	-13,24	88,14	1,39
Moduuli_222	11.5.17 15:17	19,57	20,31	3,30	9,81	32,16	2,78	-13,94	88,88	1,33	-13,55	87,99	1,35
Moduuli_222	11.5.17 16:17	19,64	20,27	3,31	9,78	32,40	2,80				-12,68	88,15	1,46
Moduuli_222	11.5.17 17:17	19,62	20,13	3,28	9,74	32,11	2,76				-13,02	87,88	1,41
Moduuli_222	11.5.17 18:17	19,54	20,04	3,25	9,68	32,00	2,74				-13,60	87,81	1,35
Moduuli_222	11.5.17 19:17	19,54	19,91	3,23	9,60	31,78	2,71				-12,22	87,94	1,51
Moduuli_222	11.5.17 20:17	19,57	21,02	3,41	10,44	35,26	3,18	-6,55	83,72	2,24	-6,32	92,19	2,51
Moduuli_222	11.5.17 21:17	19,58	20,57	3,34	10,68	31,13	2,85	-12,93	87,81	1,42	-12,61	88,69	1,47
Moduuli_222	11.5.17 22:17	19,42	20,26	3,26	10,14	31,24	2,76	-13,60	88,82	1,36	-13,17	88,16	1,40
Moduuli_222	11.5.17 23:17	19,25	20,14	3,21	9,80	31,51	2,72	-13,94	89,04	1,33	-13,54	87,99	1,36
Moduuli_222	12.5.17 0:17	19,10	20,03	3,16	9,58	31,65	2,70	-13,60	89,48	1,37	-12,94	88,14	1,43
Moduuli_222	12.5.17 1:17	18,97	19,93	3,12	9,40	31,54	2,65				-12,91	87,81	1,42
Moduuli_222	12.5.17 2:17	18,84	19,89	3,09	9,25	31,55	2,63				-13,64	87,68	1,34
Moduuli_222	12.5.17 3:17	18,70	19,78	3,04	9,10	31,32	2,58	-13,62			-12,40	87,79	1,48
Moduuli_222	12.5.17 4:17	18,64	20,93	3,21	9,86	35,04	3,04	-6,20	84,90	2,33	-5,86	92,32	2,60
Moduuli_222	12.5.17 5:17	18,62	20,53	3,14	10,08	30,97	2,73	-12,97	87,47	1,41	-12,72	88,56	1,46
Moduuli_222	12.5.17 6:17	18,50	20,30	3,08	9,53	31,20	2,65	-13,68	88,33	1,35	-13,34	87,96	1,38
Moduuli_222	12.5.17 7:17	18,50	20,27	3,08	9,21	31,76	2,64	-14,02	88,41	1,31	-13,64	87,87	1,34
Moduuli_222	12.5.17 8:17	18,48	20,23	3,07	9,05	31,98	2,63	-13,42	89,39	1,39	-12,56	87,78	1,46
Moduuli_222	12.5.17 9:17	18,48	20,19	3,06	8,96	32,05	2,62	-14,20	89,43	1,31	-13,48	87,54	1,36
Moduuli_222	12.5.17 10:17	18,58	20,23	3,09	8,94	32,32	2,64	-14,00			-13,19	87,82	1,39
Moduuli_222	12.5.17 11:17	18,69	20,20	3,10	8,92	32,19	2,62				-13,20	87,49	1,39
Moduuli_222	12.5.17 12:17	18,85	21,25	3,30	9,74	35,95	3,10	-6,36	84,02	2,28	-6,10	91,94	2,55
Moduuli_222	12.5.17 13:17	19,16	20,96	3,32	10,18	32,15	2,85				-12,72	88,46	1,46
Moduuli_222	12.5.17 14:17	19,33	20,82	3,33	9,85	32,42	2,81				-13,27	87,94	1,38
Moduuli_222	12.5.17 15:17	19,47	20,73	3,35	9,71	32,87	2,82				-13,52	87,86	1,36
Moduuli_222	12.5.17 16:17	19,59	20,70	3,37	9,68	33,17	2,84	-13,41	89,72	1,40	-12,56	87,93	1,47
Moduuli_222	12.5.17 17:17	19,66	20,60	3,36	9,68	32,92	2,82	-13,88	89,67	1,34	-12,98	87,70	1,41
Moduuli_222	12.5.17 18:17	19,62	20,45	3,33	9,66	32,76	2,81	-14,20	89,33	1,30	-13,46	87,66	1,36
Moduuli_222	12.5.17 19:17	19,62	20,32	3,31	9,62	32,50	2,78				-12,46	87,86	1,48
Moduuli_222	12.5.17 20:17	19,64	21,24	3,46	10,34	35,78	3,21	-6,50	87,39	2,35	-6,18	92,01	2,53
Moduuli_222	12.5.17 21:17	19,66	20,86	3,41	10,66	31,87	2,92				-12,76	88,52	1,45
Moduuli_222	12.5.17 22:17	19,54	20,62	3,34	10,16	31,90	2,82				-13,30	88,02	1,38
Moduuli_222	12.5.17 23:17	19,37	20,47	3,28	9,82	32,16	2,78				-13,51	87,93	1,36
Moduuli_222	13.5.17 0:17	19,17	20,31	3,22	9,59	32,28	2,75				-12,40	87,88	1,48

Moduuli_222	13.5.17 1:17	18,97	20,25	3,17	9,38	31,99	2,69					-13,18	87,59	1,39
Moduuli_222	13.5.17 2:17	18,76	20,12	3,11	9,22	31,98	2,66					-13,65	87,58	1,34
Moduuli_222	13.5.17 3:17	18,62	20,01	3,06	9,04	31,73	2,61					-12,56	87,60	1,46
Moduuli_222	13.5.17 4:17	18,59	21,14	3,23	9,74	35,62	3,07	-5,32	88,29	2,60		-4,72	92,70	2,85
Moduuli_222	13.5.17 5:17	18,62	20,85	3,19	10,07	31,50	2,77	-12,94	88,04	1,42		-12,66	88,51	1,46
Moduuli_222	13.5.17 6:17	18,56	20,58	3,14	9,52	31,70	2,69					-13,28	87,91	1,38
Moduuli_222	13.5.17 7:17	18,49	20,55	3,12	9,20	32,15	2,67					-13,60	87,79	1,35
Moduuli_222	13.5.17 8:17	18,44	20,47	3,10	9,03	32,47	2,67	-13,36	88,99	1,39		-12,48	87,74	1,47
Moduuli_222	13.5.17 9:17	18,42	20,43	3,09	8,91	32,43	2,64	-14,08	88,83	1,31		-13,32	87,43	1,37
Moduuli_222	13.5.17 10:17	18,48	20,49	3,11	8,87	32,67	2,65	-14,27	88,61	1,29		-13,62	87,59	1,34
Moduuli_222	13.5.17 11:17	18,58	20,45	3,12	8,86	32,61	2,65					-12,89	87,40	1,42
Moduuli_222	13.5.17 12:17	18,82	21,53	3,34	9,66	36,60	3,13	-5,23	87,81	2,60		-4,64	92,35	2,86
Moduuli_222	13.5.17 13:17	19,11	21,27	3,36	10,17	32,58	2,89					-12,80	88,44	1,45
Moduuli_222	13.5.17 14:17	19,27	21,09	3,36	9,83	32,82	2,84					-13,34	87,92	1,38
Moduuli_222	13.5.17 15:17	19,36	20,96	3,36	9,65	33,25	2,85							
Moduuli_222	13.5.17 16:17	19,50	21,00	3,40	9,60	33,64	2,87					-12,53	87,89	1,47
Moduuli_222	13.5.17 17:17	19,70	20,90	3,42	9,64	33,59	2,87	-13,88	89,25	1,34		-12,98	87,58	1,41
Moduuli_222	13.5.17 18:17	19,82	20,84	3,44	9,68	33,54	2,88	-14,24	89,04	1,30		-13,48	87,54	1,36
Moduuli_222	13.5.17 19:17	19,78	20,70	3,41	9,72	33,31	2,86	-13,92	89,05	1,33		-13,02	87,88	1,41
Moduuli_222	13.5.17 20:17	19,77	21,47	3,53	10,29	36,46	3,26	-5,58	89,32	2,57		-5,02	92,18	2,77
Moduuli_222	13.5.17 21:17	19,76	21,18	3,48	10,68	32,50	2,98	-13,14	88,73	1,41		-12,84	88,45	1,44
Moduuli_222	13.5.17 22:17	19,60	20,90	3,40	10,20	32,47	2,88	-13,78				-13,34	87,92	1,38
Moduuli_222	13.5.17 23:17	19,38	20,77	3,33	9,85	32,67	2,83	-13,90				-13,42	87,94	1,37
Moduuli_222	14.5.17 0:17	19,20	20,65	3,28	9,60	32,71	2,79					-12,44	87,77	1,48
Moduuli_222	14.5.17 1:17	19,02	20,53	3,22	9,40	32,56	2,74					-13,24	87,47	1,38
Moduuli_222	14.5.17 2:17	18,83	20,47	3,17	9,24	32,54	2,71	-14,28	88,75	1,29		-13,54	87,62	1,35
Moduuli_222	14.5.17 3:17	18,68	20,35	3,13	9,08	32,40	2,67	-13,90	88,68	1,33		-12,74	87,49	1,44
Moduuli_222	14.5.17 4:17	18,64	21,44	3,29	9,72	36,22	3,11	-4,90	89,87	2,73		-4,14	92,74	2,98
Moduuli_222	14.5.17 5:17	18,68	21,13	3,25	10,06	32,08	2,82	-13,04	88,58	1,42		-12,78	88,42	1,45
Moduuli_222	14.5.17 6:17	18,62	20,92	3,20	9,54	32,26	2,74	-13,78	88,58	1,34		-13,41	87,82	1,37
Moduuli_222	14.5.17 7:17	18,62	20,85	3,19	9,25	32,82	2,73					-13,52	87,81	1,36
Moduuli_222	14.5.17 8:17	18,66	20,87	3,20	9,11	33,12	2,73					-12,48	87,67	1,47
Moduuli_222	14.5.17 9:17	18,63	20,79	3,18	9,04	33,09	2,72					-13,30	87,41	1,37
Moduuli_222	14.5.17 10:17	18,71	20,79	3,20	9,00	33,27	2,73					-13,54	87,57	1,35
Moduuli_222	14.5.17 11:17	18,84	20,79	3,23	9,02	33,33	2,73					-12,86	87,36	1,42
Moduuli_222	14.5.17 12:17	19,06	21,77	3,42	9,79	37,16	3,21	-4,44	90,16	2,83		-3,58	92,73	3,11
Moduuli_222	14.5.17 13:17	19,37	21,54	3,45	10,36	33,01	2,96	-13,06	88,71	1,42		-12,84	88,45	1,44
Moduuli_222	14.5.17 14:17	19,57	21,28	3,46	10,01	33,15	2,91	-13,64	88,81	1,36		-13,32	87,85	1,38
Moduuli_222	14.5.17 15:17	19,74	21,08	3,46	9,86	33,44	2,90	-13,87	88,83	1,33		-13,48	87,73	1,36
Moduuli_222	14.5.17 16:17	19,95	20,95	3,48	9,87	33,54	2,91					-13,04	87,92	1,41
Moduuli_222	14.5.17 17:17	20,16	20,69	3,48	9,96	33,26	2,91					-12,60	87,63	1,46
Moduuli_222	14.5.17 18:17	20,25	20,39	3,45	10,00	32,78	2,87	-14,06				-13,22	87,43	1,38
Moduuli_222	14.5.17 19:17	20,28	20,11	3,41	10,02	32,38	2,84							
Moduuli_222	14.5.17 20:17	20,26	20,66	3,50	10,60	35,24	3,21	-4,36	90,84	2,87		-3,50	92,57	3,12
Moduuli_222	14.5.17 21:17	20,23	20,19	3,42	11,03	30,93	2,90	-13,06	88,90	1,42		-12,80	88,46	1,45
Moduuli_222	14.5.17 22:17	20,07	19,72	3,30	10,54	30,56	2,78	-13,68	88,75	1,35		-13,26	87,89	1,39
Moduuli_222	14.5.17 23:17	19,87	19,36	3,20	10,16	30,47	2,70					-13,44	87,77	1,36
Moduuli_222	15.5.17 0:17	19,68	19,07	3,12	9,94	30,27	2,64	-13,48	88,74	1,37		-12,70	87,88	1,45
Moduuli_222	15.5.17 1:17	19,53	18,80	3,04	9,74	29,84	2,57					-12,90	87,51	1,42
Moduuli_222	15.5.17 2:17	19,38	18,56	2,98	9,58	29,44	2,51							
Moduuli_222	15.5.17 3:17	19,24	18,32	2,91	9,47	29,19	2,47					-12,78	87,64	1,44
Moduuli_222	15.5.17 4:17	19,16	18,85	2,98	9,88	32,12	2,79	-4,54	90,36	2,82		-3,76	92,35	3,05
Moduuli_222	15.5.17 5:17	19,13	18,58	2,93	10,28	28,51	2,54							
Moduuli_222	15.5.17 6:17	19,02	18,21	2,86	9,80	28,29	2,45					-13,48	87,78	1,36
Moduuli_222	15.5.17 7:17	18,90	18,01	2,81	9,48	28,38	2,40	-13,76				-13,29	87,84	1,38
Moduuli_222	15.5.17 8:17	18,89	17,88	2,78	9,29	28,38	2,37	-13,56	88,11	1,36		-12,68	87,51	1,45
Moduuli_222	15.5.17 9:17	18,98	17,78	2,78	9,24	28,37	2,36	-14,21	87,90	1,28		-13,48	87,26	1,35
Moduuli_222	15.5.17 10:17	18,97	17,58	2,75	9,24	28,27	2,35							
Moduuli_222	15.5.17 11:17	18,33	17,18	2,58	9,00	27,35	2,24					-34,99	80,30	0,18
Moduuli_222	15.5.17 12:17	17,97	17,92	2,63	9,34	30,49	2,56	-3,84	89,25	2,93		-2,87	92,68	3,27
Moduuli_222	15.5.17 12:18	17,96	17,91	2,63	9,35	30,49	2,56	-4,17	89,15	2,86		-3,31	92,58	3,17
Moduuli_222	15.5.17 13:17	18,30	17,96	2,69	9,74	27,39	2,36					-12,94	88,32	1,43
Moduuli_222	15.5.17 14:17	18,68	17,62	2,71	9,44	27,55	2,33							

Moduuli_222	15.5.17 15:17	18,70	17,43	2,68	9,22	27,61	2,30	-13,66	87,30	1,33	-13,18	87,78	1,39
Moduuli_222	15.5.17 16:17	18,88	17,32	2,69	9,10	27,63	2,28				-12,74	87,40	1,44
Moduuli_222	15.5.17 17:17	19,31	17,22	2,75	9,20	27,76	2,30				-13,52	87,20	1,35
Moduuli_222	15.5.17 18:17	19,52	17,03	2,76	9,32	27,55	2,31	-13,96	87,34	1,30	-13,12	87,56	1,40
Moduuli_222	15.5.17 19:17	19,71	16,83	2,76	9,42	27,17	2,29	-14,06	87,31	1,29	-13,04	87,21	1,40
Moduuli_222	15.5.17 20:17	19,78	17,40	2,86	10,11	30,36	2,68	-3,33	86,03	2,94	-2,26	93,01	3,44
Moduuli_222	15.5.17 21:17	19,82	17,12	2,82	10,69	26,43	2,42				-12,89	88,43	1,44
Moduuli_222	15.5.17 22:17	19,66	16,68	2,72	10,16	25,98	2,30				-13,54	87,80	1,35
Moduuli_222	15.5.17 23:17	19,46	16,35	2,64	9,77	25,89	2,23				-13,13	87,84	1,40
Moduuli_223	8.5.17 0:11	-13,48	84,68	1,31	-13,02	78,13	1,26	9,24	18,63	1,55	19,38	12,03	1,93
Moduuli_223	8.5.17 1:11	-12,28	85,11	1,45	-12,44	78,44	1,32	8,80	18,68	1,51	19,19	11,87	1,88
Moduuli_223	8.5.17 2:11	-14,30	84,28	1,22	-13,72	77,81	1,18	8,52	18,72	1,48	19,03	11,79	1,85
Moduuli_223	8.5.17 3:11	-13,82	85,01	1,28	-13,60	78,44	1,20	8,30	18,59	1,45	18,85	11,66	1,81
Moduuli_223	8.5.17 4:11	-13,03	85,30	1,37	-13,36	78,50	1,23	8,12	18,53	1,43	18,69	11,55	1,77
Moduuli_223	8.5.17 5:11	-10,40	85,80	1,70	-11,48	79,48	1,45	7,93	18,47	1,41	18,58	11,45	1,75
Moduuli_223	8.5.17 6:11	-10,77	79,71	1,53	-9,06	73,36	1,62	8,86	21,63	1,76	18,57	12,24	1,87
Moduuli_223	8.5.17 7:11	-13,66	83,62	1,28	-12,61	75,45	1,25	9,06	18,96	1,56	18,68	12,21	1,88
Moduuli_223	8.5.17 8:11	-13,82	84,05	1,27	-13,22	77,19	1,22	8,63	18,76	1,50	18,76	12,00	1,85
Moduuli_223	8.5.17 9:11	-12,02	84,71	1,48	-12,62	77,76	1,29	8,35	18,90	1,48	18,84	11,89	1,85
Moduuli_223	8.5.17 10:11	-7,30	84,31	2,13	-10,12	77,50	1,57	8,42	19,47	1,53	18,88	11,97	1,86
Moduuli_223	8.5.17 11:11	-0,66	83,32	3,46	-6,00	77,46	2,16	9,06	20,44	1,68	18,74	12,16	1,88
Moduuli_223	8.5.17 12:11	-0,40	83,05	3,52	-5,56	76,53	2,21	9,28	19,45	1,62	17,00	12,08	1,67
Moduuli_223	8.5.17 13:11	-0,10	83,10	3,60	-5,12	75,91	2,27	9,40	20,39	1,72	17,69	12,93	1,87
Moduuli_223	8.5.17 14:11	0,28	83,07	3,70	-4,62	75,89	2,35	9,75	20,69	1,78	17,74	13,24	1,92
Moduuli_223	8.5.17 15:11	-0,24	82,06	3,52	-4,14	75,84	2,44	10,25	21,52	1,92	18,47	13,80	2,09
Moduuli_223	8.5.17 16:11	-12,88	84,34	1,37	-11,86	75,74	1,34	10,06	20,43	1,80	19,10	13,87	2,19
Moduuli_223	8.5.17 17:11	-13,26	84,78	1,34	-12,52	77,09	1,29	9,42	20,55	1,73	19,44	13,51	2,18
Moduuli_223	8.5.17 18:11	-13,42	84,85	1,32	-12,72	77,25	1,27	9,04	20,69	1,70	19,50	13,33	2,15
Moduuli_223	8.5.17 19:11	-13,42	84,89	1,32	-12,72	76,68	1,26	8,87	20,77	1,69	19,59	13,16	2,14
Moduuli_223	8.5.17 20:11	-6,26	77,76	2,13	-5,17	71,23	2,12	9,48	23,51	1,99	19,63	13,64	2,22
Moduuli_223	8.5.17 21:11	-12,55	84,21	1,41	-11,58	75,68	1,37	9,96	20,66	1,81	19,66	13,58	2,22
Moduuli_223	8.5.17 22:11	-12,78	84,81	1,39	-12,09	76,60	1,33	9,48	20,09	1,70	19,52	13,20	2,14
Moduuli_223	8.5.17 23:11	-13,18	84,97	1,35	-12,54	76,88	1,28	9,08	19,96	1,64	19,34	12,95	2,07
Moduuli_223	9.5.17 0:11	-13,38	85,05	1,33	-12,80	76,55	1,25	8,80	19,84	1,60	19,16	12,76	2,02
Moduuli_223	9.5.17 1:11	-12,16	85,79	1,48	-12,25	77,07	1,32	8,55	19,51	1,55	18,86	12,53	1,95
Moduuli_223	9.5.17 2:11	-13,04	85,78	1,38	-12,84	76,31	1,24	8,31	19,37	1,51	18,68	12,37	1,90
Moduuli_223	9.5.17 3:11	-13,42	85,85	1,34	-13,01	74,82	1,20	8,16	19,32	1,50	18,61	12,32	1,88
Moduuli_223	9.5.17 4:11	-6,04	78,68	2,19	-5,15	69,61	2,07	8,71	22,00	1,77	18,57	12,71	1,94
Moduuli_223	9.5.17 5:11	-12,76	84,98	1,39	-11,86	73,45	1,30	9,21	19,59	1,63	18,60	12,91	1,97
Moduuli_223	9.5.17 6:11	-13,26	85,81	1,35	-12,52	74,09	1,24	8,74	19,24	1,55	18,53	12,63	1,92
Moduuli_223	9.5.17 7:11	-12,88	86,74	1,41	-12,32	74,30	1,26	8,39	19,33	1,52	18,48	12,61	1,91
Moduuli_223	9.5.17 8:11	-12,68	87,32	1,44	-12,54	75,42	1,26	8,18	19,49	1,51	18,48	12,61	1,91
Moduuli_223	9.5.17 9:11	-13,47	87,50	1,36	-13,10	75,35	1,20	8,06	19,68	1,51	18,56	12,64	1,93
Moduuli_223	9.5.17 10:11	-12,23	88,22	1,51	-12,54	75,88	1,27	8,01	19,72	1,51	18,61	12,65	1,94
Moduuli_223	9.5.17 11:11	-13,36	87,72	1,37	-13,18	75,35	1,20	8,02	19,92	1,53	18,73	12,69	1,96
Moduuli_223	9.5.17 12:11	-5,66	81,00	2,32	-4,90	69,85	2,12	8,74	22,90	1,84	18,94	13,35	2,08
Moduuli_223	9.5.17 13:11	-12,78	86,43	1,42	-11,85	74,09	1,31	9,40	20,55	1,73	19,16	13,59	2,15
Moduuli_223	9.5.17 14:11	-13,17	87,28	1,39	-12,46	75,04	1,26	9,08	20,32	1,67	19,23	13,44	2,14
Moduuli_223	9.5.17 15:11	-13,06	88,05	1,41	-12,46	75,37	1,27	8,83	20,53	1,66	19,28	13,46	2,15
Moduuli_223	9.5.17 16:11	-12,32	88,61	1,51	-12,28	76,86	1,31	8,69	20,71	1,66	19,32	13,47	2,15
Moduuli_223	9.5.17 17:11	-13,26	88,88	1,40	-13,02	77,16	1,24	8,62	20,82	1,66	19,32	13,47	2,15
Moduuli_223	9.5.17 18:11	-12,28	89,38	1,52	-12,44	77,46	1,30	8,56	20,86	1,66	19,34	13,54	2,17
Moduuli_223	9.5.17 19:11	-12,92	89,46	1,45	-12,98	77,39	1,25	8,51	20,97	1,66	19,42	13,57	2,18
Moduuli_223	9.5.17 20:11	-5,14	82,59	2,46	-4,51	71,23	2,23	9,21	23,94	1,99	19,43	14,10	2,27
Moduuli_223	9.5.17 21:11	-12,74	87,30	1,44	-11,80	75,43	1,34	9,78	21,24	1,83	19,46	14,31	2,31
Moduuli_223	9.5.17 22:11	-13,18	88,06	1,40	-12,44	76,36	1,29	9,32	20,94	1,75	19,36	14,08	2,26
Moduuli_223	9.5.17 23:11	-13,00	88,73	1,43	-12,42	76,57	1,29	8,96	21,11	1,73	19,24	14,04	2,23
Moduuli_223	10.5.17 0:11	-12,30	89,18	1,52	-12,27	77,87	1,33	8,73	21,23	1,71	19,12	14,00	2,21
Moduuli_223	10.5.17 1:11	-13,30	89,34	1,40	-13,02	77,98	1,25	8,54	21,30	1,69	19,00	13,97	2,19
Moduuli_223	10.5.17 2:11	-12,31	89,79	1,53	-12,46	78,18	1,31	8,38	21,38	1,68	18,90	13,94	2,17
Moduuli_223	10.5.17 3:11	-12,93	88,84	1,44	-12,96	77,95	1,26	8,24	21,37	1,66	18,79	13,97	2,16
Moduuli_223	10.5.17 4:11	-4,58	83,44	2,59	-4,09	71,78	2,32	8,84	24,46	1,98	18,74	14,55	2,24
Moduuli_223	10.5.17 5:11	-12,81	87,42	1,43	-11,83	75,65	1,34	9,38	21,76	1,83	18,74	14,74	2,27



Moduuli_223	10.5.17 6:11	-13,29	88,03	1,38	-12,48	76,48	1,28	8,90	21,51	1,75	18,68	14,53	2,23
Moduuli_223	10.5.17 7:11	-12,76	88,71	1,46	-12,24	77,03	1,32	8,54	21,75	1,73	18,62	14,51	2,22
Moduuli_223	10.5.17 8:11	-12,60	89,00	1,48	-12,42	78,12	1,32	8,32	21,97	1,72	18,60	14,50	2,22
Moduuli_223	10.5.17 9:11	-13,42	89,21	1,39	-13,04	78,17	1,25	8,20	22,16	1,72	18,56	14,49	2,21
Moduuli_223	10.5.17 10:11	-12,14	89,70	1,55	-12,48	78,75	1,32	8,08	22,21	1,71	18,60	14,57	2,23
Moduuli_223	10.5.17 11:11	-13,24	89,71	1,42	-13,14	78,44	1,25	8,05	22,46	1,73	18,71	14,60	2,25
Moduuli_223	10.5.17 12:11	-4,40	83,91	2,64	-4,02	72,58	2,35	8,72	25,56	2,05	18,84	15,21	2,36
Moduuli_223	10.5.17 13:11	-12,72	87,78	1,45	-11,81	76,66	1,36	9,40	22,92	1,93	19,09	15,51	2,44
Moduuli_223	10.5.17 14:11	-13,18	88,53	1,40	-12,46	77,76	1,31	9,08	22,75	1,87	19,24	15,36	2,44
Moduuli_223	10.5.17 15:11	-13,20	89,18	1,41	-12,52	78,24	1,31	8,88	23,17	1,88	19,44	15,36	2,47
Moduuli_223	10.5.17 16:11	-12,10	89,79	1,55	-12,11	79,80	1,38	8,80	23,33	1,89	19,52	15,32	2,48
Moduuli_223	10.5.17 17:11	-13,04	90,07	1,45	-12,88	80,28	1,30	8,77	23,48	1,89	19,60	15,34	2,50
Moduuli_223	10.5.17 18:11	-13,32	90,45	1,42	-13,02	79,96	1,29	8,73	23,47	1,89	19,61	15,28	2,49
Moduuli_223	10.5.17 19:11	-12,39	89,48	1,51	-12,65	80,67	1,34	8,72	23,47	1,89	19,68	15,30	2,50
Moduuli_223	10.5.17 20:11	-3,48	85,42	2,88	-3,26	74,22	2,55	9,44	26,67	2,25	19,76	15,92	2,62
Moduuli_223	10.5.17 21:11	-12,70	88,54	1,46	-11,74	78,18	1,39	10,10	23,58	2,08	19,83	16,07	2,65
Moduuli_223	10.5.17 22:11	-13,15	89,20	1,42	-12,41	79,29	1,34	9,63	23,24	1,99	19,75	15,79	2,59
Moduuli_223	10.5.17 23:11	-13,20	89,74	1,42	-12,52	79,55	1,33	9,26	23,45	1,95	19,65	15,66	2,55
Moduuli_223	11.5.17 0:11	-12,00	90,21	1,57	-12,04	80,81	1,41	9,02	23,47	1,92	19,46	15,56	2,51
Moduuli_223	11.5.17 1:11	-12,82	88,79	1,45	-12,74	81,08	1,33	8,82	23,43	1,90	19,32	15,45	2,47
Moduuli_223	11.5.17 2:11	-13,44	88,45	1,37	-13,08	80,63	1,29	8,62	23,44	1,87	19,18	15,41	2,44
Moduuli_223	11.5.17 3:11	-12,34	88,42	1,50	-12,62	81,00	1,34	8,46	23,32	1,84	19,04	15,30	2,40
Moduuli_223	11.5.17 4:11	-2,97	88,19	3,09	-2,93	74,68	2,63	9,04	26,48	2,18	18,96	15,90	2,49
Moduuli_223	11.5.17 5:11	-12,72	87,78	1,45	-11,72	78,02	1,39	9,62	23,49	2,01	18,93	16,06	2,51
Moduuli_223	11.5.17 6:11	-13,22	87,48	1,38	-12,40	78,90	1,33	9,08	23,20	1,91	18,83	15,79	2,45
Moduuli_223	11.5.17 7:11	-13,18	87,64	1,39	-12,45	79,10	1,33	8,68	23,45	1,88	18,76	15,67	2,42
Moduuli_223	11.5.17 8:11	-12,30	87,75	1,49	-12,20	80,42	1,38	8,46	23,64	1,87	18,74	15,67	2,42
Moduuli_223	11.5.17 9:11	-13,20	87,39	1,38	-12,92	80,63	1,31	8,32	23,82	1,86	18,78	15,68	2,42
Moduuli_223	11.5.17 10:11	-12,96	87,68	1,42	-12,73	80,45	1,32	8,24	23,83	1,85	18,80	15,62	2,42
Moduuli_223	11.5.17 11:11	-12,80	87,14	1,43	-12,84	80,85	1,32	8,20	24,00	1,86	18,92	15,66	2,44
Moduuli_223	11.5.17 12:11	-3,05	89,74	3,13	-3,06	75,05	2,61	8,88	27,19	2,21	19,12	16,25	2,57
Moduuli_223	11.5.17 13:11	-12,84	87,46	1,43	-11,82	78,43	1,39	9,64	24,39	2,09	19,38	16,53	2,65
Moduuli_223	11.5.17 14:11	-13,24	87,12	1,38	-12,42	79,61	1,34	9,34	24,23	2,03	19,62	16,30	2,66
Moduuli_223	11.5.17 15:11	-13,06	87,34	1,40	-12,38	80,29	1,36	9,14	24,46	2,02	19,71	16,23	2,66
Moduuli_223	11.5.17 16:11	-12,21	87,28	1,50	-12,16	81,71	1,41	9,02	24,58	2,02	19,77	16,19	2,66
Moduuli_223	11.5.17 17:11	-13,04	86,87	1,39	-12,86	82,07	1,34	8,94	24,58	2,01	19,75	16,08	2,64
Moduuli_223	11.5.17 18:11	-13,28	86,89	1,37	-12,96	81,70	1,32	8,85	24,52	1,99	19,66	16,02	2,62
Moduuli_223	11.5.17 19:11	-12,32	86,96	1,48	-12,62	82,25	1,37	8,80	24,45	1,98	19,69	15,96	2,61
Moduuli_223	11.5.17 20:11	-2,25	91,37	3,38	-2,45	76,16	2,78	9,42	27,55	2,32	19,70	16,49	2,70
Moduuli_223	11.5.17 21:11	-12,78	87,29	1,43	-11,72	79,21	1,41	10,10	24,44	2,16	19,74	16,64	2,73
Moduuli_223	11.5.17 22:11	-13,20	86,87	1,38	-12,39	80,26	1,36	9,60	24,00	2,05	19,64	16,34	2,67
Moduuli_223	11.5.17 23:11	-13,15	86,98	1,38	-12,46	80,53	1,35	9,21	24,16	2,01	19,47	16,16	2,61
Moduuli_223	12.5.17 0:11	-12,10	87,08	1,51	-12,08	81,78	1,42	8,94	24,20	1,97	19,34	16,05	2,57
Moduuli_223	12.5.17 1:11	-12,92	86,67	1,40	-12,77	81,95	1,34	8,73	24,20	1,95	19,20	15,94	2,53
Moduuli_223	12.5.17 2:11	-13,34	86,71	1,36	-12,99	81,40	1,31	8,55	24,18	1,92	19,08	15,84	2,49
Moduuli_223	12.5.17 3:11	-12,49	86,76	1,46	-12,67	81,84	1,35	8,39	24,06	1,89	18,92	15,79	2,46
Moduuli_223	12.5.17 4:11	-1,74	91,62	3,52	-2,10	76,07	2,85	8,93	27,14	2,21	18,84	16,29	2,53
Moduuli_223	12.5.17 5:11	-12,82	87,18	1,42	-11,74	78,48	1,40	9,54	24,17	2,05	18,82	16,48	2,55
Moduuli_223	12.5.17 6:11	-13,30	86,65	1,36	-12,43	79,36	1,34	9,02	23,82	1,95	18,73	16,19	2,49
Moduuli_223	12.5.17 7:11	-12,72	87,02	1,43	-12,15	80,04	1,38	8,63	24,04	1,92	18,70	16,12	2,48
Moduuli_223	12.5.17 8:11	-12,62	86,65	1,44	-12,38	80,98	1,37	8,41	24,26	1,91	18,67	16,04	2,46
Moduuli_223	12.5.17 9:11	-13,44	86,27	1,34	-13,06	81,01	1,30	8,25	24,37	1,90	18,66	16,04	2,46
Moduuli_223	12.5.17 10:11	-12,10	86,79	1,50	-12,42	81,58	1,38	8,16	24,50	1,90	18,74	16,00	2,47
Moduuli_223	12.5.17 11:11	-13,26	86,16	1,36	-13,09	81,32	1,30	8,13	24,55	1,90	18,83	15,96	2,47
Moduuli_223	12.5.17 12:11	-1,98	92,37	3,49	-2,36	76,24	2,80	8,72	27,58	2,22	18,98	16,50	2,58
Moduuli_223	12.5.17 13:11	-12,80	86,95	1,42	-11,80	78,79	1,40	9,54	24,93	2,12	19,26	16,82	2,68
Moduuli_223	12.5.17 14:11	-13,22	86,53	1,37	-12,42	79,95	1,35	9,24	24,65	2,05	19,44	16,61	2,68
Moduuli_223	12.5.17 15:11	-12,92	86,86	1,41	-12,31	80,73	1,37	9,04	24,96	2,05	19,58	16,52	2,68
Moduuli_223	12.5.17 16:11	-12,28	86,76	1,48	-12,19	82,04	1,41	8,94	25,06	2,04	19,69	16,49	2,70
Moduuli_223	12.5.17 17:11	-13,02	86,41	1,39	-12,81	82,45	1,35	8,91	25,18	2,05	19,79	16,46	2,71
Moduuli_223	12.5.17 18:11	-13,12	86,61	1,38	-12,80	82,24	1,35	8,86	25,10	2,04	19,76	16,38	2,69
Moduuli_223	12.5.17 19:11	-12,28	86,69	1,48	-12,54	82,73	1,38	8,84	25,00	2,03	19,78	16,26	2,67
Moduuli_223	12.5.17 20:11	-2,14	93,14	3,47	-2,48	77,33	2,81	9,37	27,72	2,33	19,79	16,72	2,75

Moduuli_223	12.5.17 21:11	-12,86	86,93	1,42	-11,84	79,67	1,41	10,05	24,96	2,19	19,83	16,90	2,79
Moduuli_223	12.5.17 22:11	-13,24	86,53	1,37	-12,42	80,67	1,36	9,62	24,51	2,09	19,74	16,57	2,72
Moduuli_223	12.5.17 23:11	-12,52	86,90	1,45	-12,11	81,62	1,41	9,24	24,58	2,05	19,59	16,39	2,67
Moduuli_223	13.5.17 0:11	-12,38	86,54	1,46	-12,32	82,29	1,40	8,97	24,56	2,01	19,42	16,28	2,62
Moduuli_223	13.5.17 1:11	-13,18	86,07	1,37	-12,96	82,38	1,33	8,73	24,55	1,97	19,22	16,15	2,57
Moduuli_223	13.5.17 2:11	-13,04	86,49	1,39	-12,79	81,95	1,34	8,52	24,42	1,94	19,03	16,02	2,52
Moduuli_223	13.5.17 3:11	-12,60	86,20	1,43	-12,76	82,10	1,35	8,36	24,31	1,91	18,86	15,97	2,48
Moduuli_223	13.5.17 4:11	-0,58	93,12	3,90	-1,36	77,15	3,05	8,82	27,26	2,21	18,81	16,41	2,54
Moduuli_223	13.5.17 5:11	-12,78	88,02	1,44	-11,72	78,59	1,40	9,52	24,51	2,08	18,82	16,68	2,58
Moduuli_223	13.5.17 6:11	-13,25	87,42	1,38	-12,40	79,52	1,34	9,03	24,07	1,98	18,78	16,40	2,54
Moduuli_223	13.5.17 7:11	-12,84	87,70	1,43	-12,22	80,12	1,37	8,63	24,30	1,94	18,70	16,25	2,50
Moduuli_223	13.5.17 8:11	-12,46	87,39	1,47	-12,28	81,11	1,38	8,39	24,44	1,92	18,65	16,17	2,48
Moduuli_223	13.5.17 9:11	-13,30	86,98	1,37	-12,96	81,26	1,31	8,24	24,59	1,91	18,64	16,16	2,48
Moduuli_223	13.5.17 10:11	-12,39	87,51	1,48	-12,44	81,52	1,37	8,14	24,62	1,90	18,67	16,11	2,47
Moduuli_223	13.5.17 11:11	-12,91	86,96	1,41	-12,90	81,47	1,32	8,10	24,73	1,91	18,77	16,14	2,49
Moduuli_223	13.5.17 12:11	-0,52	92,57	3,89	-1,41	77,26	3,04	8,67	27,72	2,22	18,98	16,60	2,60
Moduuli_223	13.5.17 13:11	-12,84	87,67	1,43	-11,72	78,56	1,40	9,57	25,13	2,14	19,24	16,94	2,70
Moduuli_223	13.5.17 14:11	-13,22	87,29	1,38	-12,36	79,82	1,35	9,25	24,84	2,07	19,42	16,74	2,69
Moduuli_223	13.5.17 15:11	-12,70	87,55	1,44	-12,16	80,95	1,39	9,01	25,08	2,06	19,54	16,64	2,70
Moduuli_223	13.5.17 16:11	-12,30	87,25	1,49	-12,18	82,04	1,41	8,91	25,24	2,06	19,65	16,54	2,70
Moduuli_223	13.5.17 17:11	-13,02	86,93	1,40	-12,79	82,53	1,35	8,91	25,43	2,07	19,86	16,54	2,74
Moduuli_223	13.5.17 18:11	-13,28	87,04	1,37	-12,92	82,39	1,33	8,93	25,53	2,08	19,98	16,52	2,75
Moduuli_223	13.5.17 19:11	-12,06	87,33	1,52	-12,40	83,04	1,40	8,94	25,34	2,07	19,99	16,42	2,74
Moduuli_223	13.5.17 20:11	-0,86	93,08	3,81	-1,78	78,97	3,02	9,37	27,69	2,33	19,97	16,78	2,79
Moduuli_223	13.5.17 21:11	-12,86	87,59	1,43	-11,78	79,91	1,42	10,12	25,24	2,23	19,97	16,97	2,83
Moduuli_223	13.5.17 22:11	-13,20	87,30	1,38	-12,38	81,00	1,37	9,68	24,69	2,12	19,82	16,70	2,75
Moduuli_223	13.5.17 23:11	-12,26	87,62	1,50	-11,98	82,30	1,44	9,29	24,76	2,07	19,64	16,54	2,70
Moduuli_223	14.5.17 0:11	-12,48	87,27	1,47	-12,38	82,81	1,40	8,99	24,76	2,03	19,45	16,35	2,64
Moduuli_223	14.5.17 1:11	-13,27	86,94	1,37	-12,98	82,76	1,33	8,77	24,72	1,99	19,26	16,29	2,59
Moduuli_223	14.5.17 2:11	-12,38	87,46	1,48	-12,45	82,96	1,40	8,56	24,62	1,96	19,08	16,17	2,55
Moduuli_223	14.5.17 3:11	-12,78	86,91	1,42	-12,87	82,65	1,34	8,38	24,50	1,93	18,92	16,09	2,51
Moduuli_223	14.5.17 4:11	0,02	92,79	4,05	-1,02	78,45	3,18	8,80	27,38	2,21	18,85	16,49	2,56
Moduuli_223	14.5.17 5:11	-12,84	87,36	1,42	-11,74	79,10	1,41	9,55	24,78	2,11	18,90	16,83	2,62
Moduuli_223	14.5.17 6:11	-13,26	86,95	1,37	-12,40	79,96	1,35	9,06	24,34	2,00	18,86	16,56	2,57
Moduuli_223	14.5.17 7:11	-12,36	87,28	1,48	-11,98	81,18	1,42	8,68	24,60	1,97	18,85	16,43	2,55
Moduuli_223	14.5.17 8:11	-12,51	86,85	1,45	-12,34	81,85	1,39	8,48	24,79	1,96	18,85	16,36	2,54
Moduuli_223	14.5.17 9:11	-13,28	86,42	1,36	-12,94	81,92	1,33	8,36	24,88	1,95	18,85	16,29	2,53
Moduuli_223	14.5.17 10:11	-12,20	87,00	1,49	-12,38	82,42	1,39	8,28	24,92	1,94	18,86	16,23	2,52
Moduuli_223	14.5.17 11:11	-12,88	86,35	1,40	-12,88	82,29	1,34	8,22	24,96	1,94	18,92	16,22	2,53
Moduuli_223	14.5.17 12:11	0,42	93,11	4,19	-0,78	78,70	3,24	8,76	27,87	2,25	19,09	16,70	2,63
Moduuli_223	14.5.17 13:11	-12,82	87,37	1,43	-11,66	79,13	1,42	9,67	25,35	2,17	19,35	17,07	2,73
Moduuli_223	14.5.17 14:11	-13,20	86,87	1,38	-12,33	80,48	1,37	9,35	25,06	2,10	19,58	16,85	2,74
Moduuli_223	14.5.17 15:11	-12,94	87,00	1,41	-12,26	81,38	1,39	9,14	25,31	2,09	19,77	16,71	2,75
Moduuli_223	14.5.17 16:11	-12,01	86,91	1,52	-12,00	82,68	1,44	9,08	25,52	2,10	19,96	16,67	2,77
Moduuli_223	14.5.17 17:11	-12,62	86,48	1,44	-12,54	83,24	1,39	9,11	25,56	2,11	20,19	16,58	2,80
Moduuli_223	14.5.17 18:11	-13,20	86,11	1,36	-12,94	83,36	1,35	9,14	25,47	2,11	20,28	16,48	2,80
Moduuli_223	14.5.17 19:11	-12,80	86,57	1,42	-12,65	83,26	1,38	9,14	25,25	2,09	20,34	16,30	2,78
Moduuli_223	14.5.17 20:11	0,42	93,76	4,22	-0,92	80,45	3,28	9,58	27,47	2,34	20,31	16,55	2,81
Moduuli_223	14.5.17 21:11	-12,82	87,13	1,42	-11,70	80,18	1,43	10,40	24,88	2,24	20,31	16,69	2,84
Moduuli_223	14.5.17 22:11	-13,16	86,65	1,38	-12,34	81,31	1,38	9,96	24,11	2,11	20,18	16,25	2,74
Moduuli_223	14.5.17 23:11	-12,80	86,86	1,42	-12,23	81,95	1,40	9,55	24,05	2,04	20,01	15,97	2,66
Moduuli_223	15.5.17 0:11	-12,16	86,65	1,49	-12,14	82,74	1,43	9,26	23,86	1,99	19,85	15,72	2,60
Moduuli_223	15.5.17 1:11	-12,91	86,15	1,40	-12,74	82,74	1,36	9,06	23,70	1,95	19,69	15,50	2,54
Moduuli_223	15.5.17 2:11	-13,38	85,98	1,34	-13,02	82,14	1,32	8,86	23,48	1,91	19,56	15,27	2,48
Moduuli_223	15.5.17 3:11	-12,16	86,39	1,49	-12,50	82,33	1,38	8,70	23,21	1,86	19,42	15,09	2,43
Moduuli_223	15.5.17 4:11	0,25	93,94	4,17	-1,16	79,74	3,20	8,97	25,26	2,07	19,32	15,19	2,43
Moduuli_223	15.5.17 5:11	-12,89	86,68	1,41	-11,78	78,47	1,39	9,72	23,14	1,99	19,30	15,45	2,47
Moduuli_223	15.5.17 6:11	-13,14	86,37	1,37	-12,31	79,30	1,35	9,26	22,42	1,87	19,20	15,02	2,38
Moduuli_223	15.5.17 7:11	-12,04	86,57	1,51	-11,92	80,51	1,41	8,87	22,43	1,82	19,08	14,79	2,33
Moduuli_223	15.5.17 8:11	-12,72	86,10	1,42	-12,50	80,67	1,35	8,62	22,42	1,79	19,03	14,60	2,29
Moduuli_223	15.5.17 9:11	-13,36	85,82	1,34	-13,02	80,41	1,29	8,50	22,47	1,78	19,10	14,53	2,29
Moduuli_223	15.5.17 10:11	-12,06	86,42	1,50	-12,38	80,88	1,37	8,41	22,35	1,76	19,09	14,39	2,27
Moduuli_223	15.5.17 11:11	-13,06	85,80	1,37	-12,98	80,17	1,29	8,21	21,58	1,68	18,43	13,95	2,11

Moduuli_223	15.5.17 12:11	1,02	93,97	4,41	-0,54	77,89	3,27	8,33	23,60	1,85	17,98	14,11	2,07
Moduuli_223	15.5.17 13:11	-12,78	86,72	1,42	-11,60	76,07	1,37	9,03	21,94	1,80	18,28	14,60	2,19
Moduuli_223	15.5.17 14:11	-13,02	86,36	1,39	-12,18	77,07	1,33	8,79	21,70	1,75	18,80	14,37	2,22
Moduuli_223	15.5.17 15:11	-12,06	86,47	1,50	-11,86	78,45	1,38	8,52	21,68	1,72	18,81	14,17	2,19
Moduuli_223	15.5.17 16:11	-12,75	86,01	1,41	-12,42	78,67	1,33	8,38	21,77	1,71	18,96	14,09	2,20
Moduuli_223	15.5.17 17:11	-13,39	85,76	1,34	-12,92	78,61	1,27	8,48	22,05	1,74	19,43	14,04	2,26
Moduuli_223	15.5.17 18:11	-12,10	86,36	1,49	-12,36	79,38	1,35	8,59	21,89	1,74	19,68	13,92	2,28
Moduuli_223	15.5.17 19:11	-13,02	85,83	1,38	-12,92	79,10	1,28	8,70	21,74	1,75	19,86	13,77	2,28
Moduuli_223	15.5.17 20:11	1,52	93,92	4,57	-0,22	77,78	3,34	9,24	23,82	1,98	19,94	14,00	2,33
Moduuli_223	15.5.17 21:11	-12,74	86,87	1,43	-11,49	76,03	1,38	10,19	21,66	1,92	20,01	14,22	2,37
Moduuli_223	15.5.17 22:11	-13,06	86,49	1,39	-12,13	76,96	1,33	9,76	20,79	1,79	19,88	13,78	2,28
Moduuli_223	15.5.17 23:11	-12,08	86,61	1,50	-11,84	78,20	1,38	9,34	20,66	1,73	19,69	13,52	2,21
Moduuli_599	8.5.17 0:50	19,80	58,88	9,70	9,79	24,13	2,08	10,95	21,80	2,04	19,72	48,07	7,88
Moduuli_599	8.5.17 1:50	19,55	58,91	9,55	9,48	24,06	2,04	10,64	21,87	2,00	19,46	48,04	7,75
Moduuli_599	8.5.17 2:50	19,34	58,93	9,43	9,26	24,32	2,03	10,45	22,32	2,02	19,26	47,98	7,64
Moduuli_599	8.5.17 3:50	19,16	58,91	9,32	9,10	24,51	2,02	10,27	22,52	2,01	19,06	47,89	7,53
Moduuli_599	8.5.17 4:50	18,97	58,91	9,21	8,91	24,51	2,00	10,08	22,39	1,97	18,88	47,83	7,44
Moduuli_599	8.5.17 5:50	18,83	58,99	9,15	9,38	29,87	2,51	10,54	29,17	2,65	18,74	47,80	7,37
Moduuli_599	8.5.17 6:50	18,90	59,11	9,21	9,82	28,60	2,48	10,92	25,48	2,37	18,82	47,77	7,40
Moduuli_599	8.5.17 7:50	18,94	59,02	9,22	9,20	25,03	2,08	10,32	22,58	2,02	18,86	47,74	7,42
Moduuli_599	8.5.17 8:50	19,03	58,79	9,23	8,95	24,42	1,99	10,06	22,26	1,96	18,94	47,68	7,44
Moduuli_599	8.5.17 9:50	19,12	58,53	9,24	9,01	25,41	2,08	10,14	23,81	2,11	19,02	47,62	7,47
Moduuli_599	8.5.17 10:50	19,23	58,36	9,28	9,78	30,25	2,61	10,96	29,93	2,80	19,14	47,56	7,52
Moduuli_599	8.5.17 11:50	18,46	58,19	8,82	10,74	36,01	3,31	12,09	35,14	3,54	18,41	47,17	7,13
Moduuli_599	8.5.17 12:50	18,14	58,85	8,74	11,00	37,37	3,50	12,42	35,85	3,69	18,09	47,74	7,07
Moduuli_599	8.5.17 13:50	18,55	58,45	8,91	11,31	37,92	3,63	12,70	36,19	3,79	18,50	47,47	7,21
Moduuli_599	8.5.17 14:50	18,98	58,39	9,14	11,62	38,66	3,77	13,03	36,57	3,91	19,07	47,62	7,50
Moduuli_599	8.5.17 15:50	19,46	58,02	9,36	11,48	34,02	3,29	12,83	29,02	3,07	19,44	47,80	7,70
Moduuli_599	8.5.17 16:50	19,85	57,45	9,49	10,41	29,17	2,63	11,67	23,29	2,28	19,79	47,86	7,88
Moduuli_599	8.5.17 17:50	19,94	56,87	9,45	9,92	28,67	2,50	11,11	22,58	2,13	19,86	47,80	7,90
Moduuli_599	8.5.17 18:50	20,06	56,50	9,46	9,72	28,92	2,49	10,88	22,77	2,12	19,96	47,80	7,95
Moduuli_599	8.5.17 19:50	20,08	56,09	9,40	9,88	29,11	2,53	11,08	25,89	2,44	20,00	47,71	7,96
Moduuli_599	8.5.17 20:50	20,09	55,92	9,38	10,71	31,95	2,94	11,84	26,25	2,60	19,98	47,65	7,94
Moduuli_599	8.5.17 21:50	19,96	55,69	9,26	10,12	29,05	2,57	11,27	23,03	2,20	19,85	47,62	7,87
Moduuli_599	8.5.17 22:50	19,74	55,49	9,11	9,72	28,79	2,48	10,90	22,64	2,11	19,65	47,56	7,76
Moduuli_599	8.5.17 23:50	19,54	55,31	8,97	9,46	29,02	2,45	10,64	22,77	2,08	19,43	47,56	7,66
Moduuli_599	9.5.17 0:50	19,33	55,11	8,82	9,27	29,24	2,44	10,46	23,10	2,09	19,24	47,50	7,56
Moduuli_599	9.5.17 1:50	19,20	54,99	8,73	9,12	30,12	2,49	10,30	23,55	2,11	19,08	47,50	7,48
Moduuli_599	9.5.17 2:50	19,08	54,97	8,66	9,02	31,51	2,58	10,18	24,29	2,15	18,95	47,56	7,43
Moduuli_599	9.5.17 3:50	18,99	55,14	8,64	9,12	30,94	2,56	10,32	27,52	2,46	18,86	47,65	7,40
Moduuli_599	9.5.17 4:50	18,95	55,54	8,68	9,97	35,01	3,06	11,05	28,22	2,65	18,81	47,80	7,40
Moduuli_599	9.5.17 5:50	18,88	55,92	8,70	9,38	32,95	2,77	10,49	25,25	2,29	18,73	48,04	7,40
Moduuli_599	9.5.17 6:50	18,78	56,35	8,71	9,08	33,30	2,74	10,14	25,32	2,24	18,64	48,39	7,42
Moduuli_599	9.5.17 7:50	18,77	56,78	8,77	8,92	33,89	2,76	9,96	25,73	2,25	18,63	48,78	7,47
Moduuli_599	9.5.17 8:50	18,86	57,22	8,89	8,88	34,36	2,79	9,87	25,86	2,25	18,72	49,17	7,57
Moduuli_599	9.5.17 9:50	18,95	57,62	9,00	8,92	34,64	2,82	9,88	26,37	2,29	18,82	49,55	7,68
Moduuli_599	9.5.17 10:50	19,10	58,08	9,16	8,98	34,89	2,85	9,92	26,31	2,29	18,94	49,96	7,80
Moduuli_599	9.5.17 11:50	19,26	58,48	9,31	9,24	32,86	2,74	10,24	29,24	2,60	19,10	50,38	7,94
Moduuli_599	9.5.17 12:50	19,52	58,85	9,53	10,32	36,28	3,25	11,19	29,33	2,78	19,36	50,70	8,13
Moduuli_599	9.5.17 13:50	19,66	59,22	9,67	9,91	33,64	2,93	10,79	25,93	2,39	19,49	51,14	8,26
Moduuli_599	9.5.17 14:50	19,74	59,56	9,77	9,73	33,52	2,88	10,61	25,73	2,35	19,57	51,61	8,38
Moduuli_599	9.5.17 15:50	19,83	59,85	9,88	9,71	33,77	2,90	10,57	25,99	2,37	19,66	52,02	8,49
Moduuli_599	9.5.17 16:50	19,88	60,10	9,95	9,72	34,08	2,93	10,57	25,93	2,36	19,72	52,40	8,59
Moduuli_599	9.5.17 17:50	19,92	60,42	10,03	9,74	34,14	2,94	10,59	26,12	2,38	19,73	52,81	8,66
Moduuli_599	9.5.17 18:50	20,04	60,67	10,14	9,80	34,30	2,96	10,62	26,18	2,39	19,84	53,19	8,78
Moduuli_599	9.5.17 19:50	20,06	60,87	10,19	10,02	32,39	2,84	10,94	29,11	2,72	19,89	53,40	8,84
Moduuli_599	9.5.17 20:50	20,06	61,18	10,24	11,00	35,70	3,34	11,81	28,92	2,86	19,88	53,69	8,89
Moduuli_599	9.5.17 21:50	19,97	61,49	10,24	10,46	33,20	3,00	11,28	25,61	2,44	19,81	54,04	8,91
Moduuli_599	9.5.17 22:50	19,84	61,80	10,20	10,10	33,20	2,93	10,96	25,48	2,38	19,67	54,39	8,89
Moduuli_599	9.5.17 23:50	19,68	62,08	10,15	9,90	33,64	2,93	10,76	25,86	2,38	19,52	54,68	8,85
Moduuli_599	10.5.17 1:50	19,42	62,62	10,07	9,64	34,26	2,93	10,48	26,18	2,37	19,27	55,28	8,81
Moduuli_599	10.5.17 2:50	19,29	62,87	10,03	9,52	34,54	2,93	10,36	26,31	2,36	19,14	55,57	8,79
Moduuli_599	10.5.17 3:50	19,17	63,15	10,00	9,60	32,70	2,79	10,52	29,27	2,66	19,02	55,83	8,76

Moduuli 599	10.5.17 4:50	19,11	63,54	10,03	10,50	36,41	3,30	11,31	29,59	2,83	18,97	56,06	8,77
Moduuli 599	10.5.17 5:50	19,04	63,82	10,03	9,88	33,64	2,92	10,68	25,99	2,38	18,90	56,35	8,78
Moduuli 599	10.5.17 6:50	19,00	64,05	10,04	9,52	33,70	2,86	10,33	25,86	2,32	18,84	56,64	8,79
Moduuli 599	10.5.17 7:50	18,96	64,21	10,04	9,35	34,14	2,86	10,14	26,21	2,32	18,80	56,90	8,81
Moduuli 599	10.5.17 8:50	19,00	64,35	10,09	9,27	34,51	2,88	10,04	26,31	2,31	18,84	57,13	8,86
Moduuli 599	10.5.17 9:50	18,99	64,49	10,10	9,25	34,70	2,89	10,00	26,63	2,33	18,84	57,33	8,90
Moduuli 599	10.5.17 10:50	19,12	64,58	10,20	9,28	34,89	2,91	10,00	26,60	2,33	18,96	57,56	9,00
Moduuli 599	10.5.17 11:50	19,28	64,66	10,31	9,48	32,58	2,76	10,27	29,30	2,61	19,09	57,73	9,10
Moduuli 599	10.5.17 12:50	19,49	64,97	10,50	10,56	36,50	3,32	11,24	29,93	2,85	19,32	57,91	9,26
Moduuli 599	10.5.17 13:50	19,74	65,00	10,67	10,18	33,83	3,00	10,84	26,31	2,44	19,54	58,08	9,41
Moduuli 599	10.5.17 14:50	20,00	64,97	10,83	10,06	33,70	2,96	10,70	26,09	2,40	19,80	58,25	9,59
Moduuli 599	10.5.17 15:50	20,15	64,80	10,91	10,07	33,89	2,98	10,74	26,37	2,43	19,95	58,34	9,70
Moduuli 599	10.5.17 16:50	20,34	64,78	11,03	10,16	34,14	3,02	10,80	26,31	2,43	20,12	58,48	9,82
Moduuli 599	10.5.17 17:50	20,40	64,64	11,05	10,26	34,08	3,04	10,88	26,37	2,45	20,19	58,54	9,88
Moduuli 599	10.5.17 18:50	20,44	64,72	11,09	10,30	34,20	3,06	10,94	26,50	2,47	20,21	58,68	9,91
Moduuli 599	10.5.17 19:50	20,46	64,72	11,10	10,52	32,33	2,93	11,24	29,40	2,80	20,26	58,76	9,96
Moduuli 599	10.5.17 20:50	20,51	65,08	11,20	11,53	35,82	3,47	12,20	29,43	2,98	20,32	58,85	10,01
Moduuli 599	10.5.17 21:50	20,44	65,25	11,18	10,96	33,02	3,08	11,66	25,67	2,51	20,25	58,99	9,99
Moduuli 599	10.5.17 22:50	20,31	65,28	11,10	10,62	33,02	3,02	11,32	25,51	2,44	20,13	59,16	9,95
Moduuli 599	10.5.17 23:50	20,15	65,33	11,00	10,40	33,39	3,01	11,12	25,86	2,44	19,98	59,28	9,87
Moduuli 599	11.5.17 0:50	19,95	65,42	10,88	10,22	33,73	3,00	10,94	26,05	2,43	19,80	59,39	9,78
Moduuli 599	11.5.17 1:50	19,77	65,50	10,77	10,07	34,02	2,99	10,80	26,12	2,41	19,61	59,53	9,69
Moduuli 599	11.5.17 2:50	19,60	65,61	10,67	9,93	34,20	2,98	10,66	26,44	2,42	19,43	59,65	9,60
Moduuli 599	11.5.17 3:50	19,42	65,75	10,58	9,96	32,55	2,84	10,78	29,43	2,72	19,27	59,76	9,52
Moduuli 599	11.5.17 4:50	19,34	66,16	10,59	10,87	36,50	3,39	11,59	30,00	2,92	19,19	59,85	9,49
Moduuli 599	11.5.17 5:50	19,23	66,36	10,55	10,20	33,48	2,97	10,93	26,05	2,43	19,06	60,04	9,45
Moduuli 599	11.5.17 6:50	19,16	66,41	10,51	9,78	33,45	2,89	10,52	25,86	2,35	19,00	60,24	9,44
Moduuli 599	11.5.17 7:50	19,13	66,41	10,49	9,60	33,92	2,89	10,30	26,31	2,35	18,99	60,33	9,45
Moduuli 599	11.5.17 8:50	19,16	66,38	10,51	9,52	34,30	2,91	10,20	26,41	2,34	19,00	60,47	9,48
Moduuli 599	11.5.17 9:50	19,24	66,30	10,55	9,50	34,39	2,91	10,16	26,63	2,36	19,07	60,47	9,52
Moduuli 599	11.5.17 10:50	19,36	66,27	10,62	9,52	34,58	2,93	10,18	26,82	2,38	19,19	60,61	9,61
Moduuli 599	11.5.17 11:50	19,54	66,19	10,73	9,75	32,51	2,80	10,48	29,43	2,66	19,39	60,67	9,74
Moduuli 599	11.5.17 12:50	19,85	66,47	10,98	10,89	36,50	3,39	11,49	30,25	2,93	19,67	60,67	9,91
Moduuli 599	11.5.17 13:50	20,12	66,47	11,17	10,52	33,52	3,04	11,14	26,31	2,49	20,00	60,84	10,15
Moduuli 599	11.5.17 14:50	20,34	66,19	11,27	10,40	33,33	3,00	11,01	26,05	2,44	20,19	60,76	10,25
Moduuli 599	11.5.17 15:50	20,53	66,03	11,38	10,43	33,55	3,03	11,04	26,25	2,46	20,34	60,84	10,36
Moduuli 599	11.5.17 16:50	20,57	65,86	11,38	10,47	33,77	3,05	11,08	26,18	2,47	20,38	60,84	10,39
Moduuli 599	11.5.17 17:50	20,49	65,83	11,32	10,48	33,80	3,06	11,10	26,25	2,47	20,30	60,84	10,34
Moduuli 599	11.5.17 18:50	20,47	65,89	11,31	10,44	33,77	3,05	11,10	26,41	2,49	20,27	60,95	10,34
Moduuli 599	11.5.17 19:50	20,45	65,83	11,29	10,60	31,89	2,91	11,33	29,02	2,78	20,27	60,93	10,33
Moduuli 599	11.5.17 20:50	20,43	66,25	11,35	11,60	35,79	3,49	12,25	29,65	3,02	20,27	60,95	10,34
Moduuli 599	11.5.17 21:50	20,32	66,44	11,30	11,00	32,89	3,08	11,68	25,64	2,51	20,16	61,10	10,29
Moduuli 599	11.5.17 22:50	20,14	66,50	11,19	10,60	32,83	2,99	11,28	25,48	2,43	19,98	61,24	10,20
Moduuli 599	11.5.17 23:50	19,96	66,52	11,07	10,35	33,20	2,98	11,04	25,80	2,42	19,80	61,32	10,10
Moduuli 599	12.5.17 0:50	19,78	66,55	10,95	10,16	33,58	2,97	10,86	25,99	2,41	19,62	61,41	10,00
Moduuli 599	12.5.17 1:50	19,61	66,63	10,85	10,00	33,86	2,97	10,70	26,12	2,40	19,46	61,49	9,92
Moduuli 599	12.5.17 2:50	19,44	66,69	10,74	9,86	34,08	2,96	10,56	26,44	2,40	19,30	61,55	9,83
Moduuli 599	12.5.17 3:50	19,26	66,83	10,64	9,87	32,20	2,80	10,65	29,05	2,66	19,13	61,63	9,74
Moduuli 599	12.5.17 4:50	19,19	67,27	10,67	10,82	36,59	3,39	11,52	30,38	2,94	19,05	61,72	9,70
Moduuli 599	12.5.17 5:50	19,08	67,46	10,63	10,14	33,42	2,96	10,84	26,12	2,42	18,95	61,86	9,66
Moduuli 599	12.5.17 6:50	19,05	67,46	10,61	9,74	33,33	2,87	10,44	25,93	2,34	18,90	62,05	9,66
Moduuli 599	12.5.17 7:50	19,05	67,38	10,59	9,56	33,77	2,87	10,22	26,25	2,33	18,92	62,11	9,69
Moduuli 599	12.5.17 8:50	19,06	67,30	10,59	9,50	34,14	2,89	10,13	26,37	2,33	18,90	62,08	9,67
Moduuli 599	12.5.17 9:50	19,12	67,24	10,62	9,46	34,33	2,90	10,11	26,76	2,36	18,97	62,19	9,73
Moduuli 599	12.5.17 10:50	19,22	67,19	10,68	9,50	34,58	2,93	10,10	26,69	2,35	19,08	62,22	9,80
Moduuli 599	12.5.17 11:50	19,42	67,05	10,79	9,65	31,95	2,73	10,34	28,86	2,59	19,23	62,17	9,88
Moduuli 599	12.5.17 12:50	19,69	67,35	11,02	10,82	36,47	3,38	11,38	30,57	2,94	19,50	62,28	10,07
Moduuli 599	12.5.17 13:50	19,99	67,27	11,21	10,48	33,52	3,03	11,02	26,44	2,48	19,80	62,34	10,27
Moduuli 599	12.5.17 14:50	20,22	67,00	11,33	10,34	33,27	2,98	10,90	26,12	2,43	20,02	62,34	10,41
Moduuli 599	12.5.17 15:50	20,43	66,77	11,44	10,40	33,45	3,01	10,94	26,31	2,45	20,20	62,28	10,52
Moduuli 599	12.5.17 16:50	20,63	66,50	11,53	10,50	33,70	3,05	11,02	26,28	2,46	20,38	62,17	10,61
Moduuli 599	12.5.17 17:50	20,61	66,36	11,49	10,56	33,67	3,06	11,10	26,31	2,48	20,38	62,14	10,61
Moduuli 599	12.5.17 18:50	20,62	66,39	11,50	10,58	33,61	3,06	11,15	26,44	2,50	20,40	62,20	10,63

Moduuli 599	12.5.17 19:50	20,56	66,36	11,46	10,66	30,94	2,83	11,34	28,16	2,70	20,36	62,17	10,60
Moduuli 599	12.5.17 20:50	20,54	66,80	11,52	11,63	35,29	3,45	12,22	29,49	2,99	20,36	62,25	10,62
Moduuli 599	12.5.17 21:50	20,45	66,94	11,48	11,08	32,70	3,08	11,71	25,73	2,53	20,28	62,37	10,58
Moduuli 599	12.5.17 22:50	20,28	66,97	11,36	10,70	32,70	3,00	11,36	25,54	2,45	20,11	62,48	10,49
Moduuli 599	12.5.17 23:50	20,07	66,99	11,22	10,46	33,08	2,99	11,14	25,83	2,44	19,92	62,51	10,37
Moduuli 599	13.5.17 0:50	19,84	67,08	11,08	10,26	33,52	2,99	10,94	25,86	2,41	19,68	62,56	10,23
Moduuli 599	13.5.17 1:50	19,59	67,16	10,92	10,08	33,77	2,97	10,75	26,18	2,41	19,44	62,65	10,09
Moduuli 599	13.5.17 2:50	19,36	67,30	10,79	9,88	33,92	2,95	10,58	26,41	2,41	19,23	62,73	9,97
Moduuli 599	13.5.17 3:50	19,21	67,41	10,70	9,83	31,82	2,76	10,61	28,60	2,61	19,06	62,81	9,88
Moduuli 599	13.5.17 4:50	19,17	67,88	10,75	10,82	36,63	3,39	11,48	30,69	2,97	19,02	62,95	9,88
Moduuli 599	13.5.17 5:50	19,13	68,07	10,75	10,20	33,42	2,97	10,84	26,21	2,43	18,97	63,07	9,87
Moduuli 599	13.5.17 6:50	19,06	68,01	10,70	9,79	33,23	2,87	10,45	25,93	2,34	18,90	63,18	9,84
Moduuli 599	13.5.17 7:50	19,01	67,96	10,66	9,59	33,58	2,86	10,24	26,25	2,34	18,85	63,21	9,81
Moduuli 599	13.5.17 8:50	19,00	67,88	10,64	9,50	34,05	2,88	10,12	26,31	2,32	18,86	63,21	9,82
Moduuli 599	13.5.17 9:50	19,04	67,79	10,65	9,46	34,20	2,89	10,08	26,66	2,35	18,88	63,26	9,84
Moduuli 599	13.5.17 10:50	19,14	67,74	10,71	9,46	34,45	2,91	10,08	26,82	2,36	18,96	63,26	9,89
Moduuli 599	13.5.17 11:50	19,36	67,60	10,83	9,63	32,01	2,74	10,30	28,79	2,57	19,17	63,26	10,02
Moduuli 599	13.5.17 12:50	19,63	67,85	11,06	10,84	36,75	3,41	11,40	31,07	2,99	19,45	63,26	10,20
Moduuli 599	13.5.17 13:50	19,92	67,88	11,26	10,48	33,52	3,03	11,02	26,57	2,49	19,73	63,38	10,39
Moduuli 599	13.5.17 14:50	20,13	67,60	11,36	10,33	33,27	2,98	10,88	26,18	2,43	19,93	63,32	10,51
Moduuli 599	13.5.17 15:50	20,28	67,41	11,44	10,34	33,52	3,00	10,90	26,37	2,45	20,08	63,29	10,61
Moduuli 599	13.5.17 16:50	20,62	67,13	11,63	10,46	33,80	3,05	11,00	26,37	2,47	20,37	63,21	10,78
Moduuli 599	13.5.17 17:50	20,85	66,83	11,74	10,63	33,83	3,09	11,15	26,44	2,50	20,60	63,04	10,91
Moduuli 599	13.5.17 18:50	20,86	66,66	11,72	10,74	33,83	3,11	11,28	26,63	2,54	20,65	62,93	10,92
Moduuli 599	13.5.17 19:50	20,80	66,66	11,68	10,77	30,34	2,80	11,44	27,46	2,65	20,61	62,96	10,90
Moduuli 599	13.5.17 20:50	20,75	67,13	11,73	11,77	35,08	3,46	12,34	29,65	3,03	20,55	63,10	10,89
Moduuli 599	13.5.17 21:50	20,60	67,38	11,66	11,24	32,77	3,12	11,84	25,86	2,56	20,42	63,27	10,83
Moduuli 599	13.5.17 22:50	20,37	67,44	11,51	10,84	32,73	3,03	11,50	25,67	2,49	20,20	63,35	10,70
Moduuli 599	13.5.17 23:50	20,12	67,49	11,34	10,56	33,14	3,01	11,24	25,93	2,47	19,98	63,43	10,57
Moduuli 599	14.5.17 0:50	19,90	67,57	11,20	10,34	33,61	3,01	11,01	25,99	2,44	19,75	63,49	10,43
Moduuli 599	14.5.17 1:50	19,66	67,66	11,05	10,14	33,83	2,99	10,84	26,31	2,44	19,51	63,54	10,28
Moduuli 599	14.5.17 2:50	19,43	67,74	10,90	9,96	33,98	2,97	10,64	26,50	2,42	19,30	63,63	10,16
Moduuli 599	14.5.17 3:50	19,27	67,85	10,81	9,88	31,73	2,76	10,65	28,44	2,60	19,13	63,68	10,06
Moduuli 599	14.5.17 4:50	19,22	68,29	10,85	10,87	36,72	3,41	11,51	31,01	3,00	19,10	63,80	10,06
Moduuli 599	14.5.17 5:50	19,19	68,48	10,86	10,26	33,48	2,99	10,90	26,44	2,46	19,06	63,94	10,06
Moduuli 599	14.5.17 6:50	19,22	68,40	10,87	9,87	33,39	2,90	10,53	26,18	2,38	19,06	64,02	10,07
Moduuli 599	14.5.17 7:50	19,25	68,23	10,86	9,73	33,80	2,91	10,36	26,44	2,37	19,10	64,02	10,10
Moduuli 599	14.5.17 8:50	19,26	68,12	10,85	9,66	34,14	2,92	10,30	26,53	2,37	19,11	63,96	10,09
Moduuli 599	14.5.17 9:50	19,28	68,04	10,85	9,65	34,20	2,93	10,28	26,82	2,39	19,12	63,96	10,10
Moduuli 599	14.5.17 10:50	19,37	67,96	10,90	9,64	34,08	2,91	10,28	26,88	2,40	19,18	63,96	10,14
Moduuli 599	14.5.17 11:50	19,58	67,77	11,01	9,78	31,57	2,73	10,48	28,57	2,58	19,36	63,91	10,24
Moduuli 599	14.5.17 12:50	19,86	67,90	11,23	11,03	36,44	3,42	11,59	31,20	3,04	19,65	63,94	10,43
Moduuli 599	14.5.17 13:50	20,15	67,77	11,41	10,63	32,64	2,98	11,20	26,31	2,50	19,91	64,02	10,62
Moduuli 599	14.5.17 14:50	20,42	67,30	11,52	10,48	32,04	2,90	11,08	25,86	2,44	20,19	63,88	10,78
Moduuli 599	14.5.17 15:50	20,70	66,80	11,63	10,52	32,01	2,90	11,12	25,93	2,45	20,42	63,71	10,90
Moduuli 599	14.5.17 16:50	21,02	66,31	11,77	10,66	31,95	2,93	11,25	25,96	2,47	20,72	63,49	11,07
Moduuli 599	14.5.17 17:50	21,19	65,81	11,81	10,81	31,95	2,95	11,41	25,77	2,48	20,92	63,27	11,17
Moduuli 599	14.5.17 18:50	21,27	65,50	11,81	10,90	31,82	2,96	11,54	25,80	2,50	21,02	63,07	11,20
Moduuli 599	14.5.17 19:50	21,22	65,28	11,74	10,94	29,17	2,72	11,70	26,63	2,61	20,99	62,93	11,15
Moduuli 599	14.5.17 20:50	21,14	65,56	11,73	11,98	33,95	3,39	12,65	29,33	3,06	20,94	62,96	11,13
Moduuli 599	14.5.17 21:50	20,98	65,67	11,63	11,40	30,76	2,96	12,13	25,03	2,53	20,80	62,99	11,04
Moduuli 599	14.5.17 22:50	20,75	65,56	11,45	10,95	30,44	2,84	11,76	24,64	2,43	20,57	62,96	10,88
Moduuli 599	14.5.17 23:50	20,53	65,39	11,27	10,69	30,69	2,82	11,50	24,90	2,41	20,36	62,90	10,73
Moduuli 599	15.5.17 0:50	20,32	65,28	11,10	10,46	31,01	2,80	11,28	24,97	2,38	20,14	62,82	10,57
Moduuli 599	15.5.17 1:50	20,12	65,14	10,94	10,28	31,16	2,78	11,10	25,09	2,37	19,94	62,73	10,42
Moduuli 599	15.5.17 2:50	19,94	65,03	10,80	10,10	31,38	2,77	10,94	25,35	2,36	19,78	62,65	10,31
Moduuli 599	15.5.17 3:50	19,75	64,94	10,66	9,93	29,05	2,53	10,86	26,12	2,42	19,62	62,51	10,18
Moduuli 599	15.5.17 4:50	19,65	65,22	10,64	10,86	34,42	3,19	11,68	29,52	2,89	19,52	62,51	10,12
Moduuli 599	15.5.17 5:50	19,52	65,33	10,58	10,26	31,38	2,80	11,10	25,29	2,38	19,38	62,53	10,04
Moduuli 599	15.5.17 6:50	19,35	65,22	10,45	9,84	31,16	2,70	10,70	24,90	2,29	19,22	62,48	9,93
Moduuli 599	15.5.17 7:50	19,24	65,14	10,36	9,59	31,42	2,68	10,46	25,03	2,26	19,11	62,45	9,85
Moduuli 599	15.5.17 8:50	19,30	65,00	10,38	9,48	31,70	2,68	10,32	25,22	2,26	19,17	62,36	9,88
Moduuli 599	15.5.17 9:50	19,40	64,66	10,39	9,46	31,82	2,69	10,30	25,54	2,28	19,25	62,11	9,89

Moduuli 599	15.5.17 10:50	19,10	64,49	10,17	9,39	31,79	2,67	10,24	25,41	2,26	18,92	61,86	9,65
Moduuli 599	15.5.17 11:50	18,56	64,80	9,88	9,16	29,93	2,48	10,10	26,57	2,34	18,37	62,00	9,34
Moduuli 599	15.5.17 12:50	18,50	65,27	9,92	10,09	35,60	3,14	10,89	30,38	2,82	18,31	62,25	9,34
Moduuli 599	15.5.17 13:50	19,12	65,00	10,26	9,64	31,38	2,68	10,40	25,41	2,29	18,94	62,17	9,71
Moduuli 599	15.5.17 14:50	19,30	64,47	10,29	9,44	30,60	2,58	10,22	24,71	2,20	19,16	61,91	9,80
Moduuli 599	15.5.17 15:50	19,38	64,08	10,28	9,38	30,34	2,55	10,21	24,39	2,17	19,30	61,63	9,84
Moduuli 599	15.5.17 16:50	19,89	63,63	10,54	9,50	30,22	2,56	10,33	24,42	2,19	19,83	61,38	10,13
Moduuli 599	15.5.17 17:50	20,25	62,98	10,67	9,73	30,06	2,59	10,59	24,58	2,24	20,19	60,95	10,29
Moduuli 599	15.5.17 18:50	20,50	62,59	10,77	9,91	29,87	2,60	10,80	24,39	2,25	20,42	60,67	10,38
Moduuli 599	15.5.17 19:50	20,62	62,25	10,79	10,12	28,41	2,51	11,11	25,73	2,43	20,55	60,36	10,41
Moduuli 599	15.5.17 20:50	20,64	62,42	10,83	11,35	33,92	3,25	12,24	29,18	2,97	20,56	60,22	10,40
Moduuli 599	15.5.17 21:50	20,50	62,51	10,75	10,81	29,62	2,74	11,76	24,19	2,38	20,42	60,25	10,31
Moduuli 599	15.5.17 22:50	20,26	62,48	10,59	10,37	28,92	2,60	11,36	23,52	2,26	20,18	60,25	10,16
Moduuli 599	15.5.17 23:50	20,01	62,37	10,41	10,07	28,92	2,55	11,08	23,48	2,21	19,92	60,19	9,99